

Variable displacement vane pumps (with hydraulic pressure compensator)

PHV-Type



Key Features:

- Rotation:** Right (viewed from shaft end)
- Mounting flanges:** 4-hole flange (UNI ISO 3019/2) and Rectangular Flange as gear pump Size 2 (only for Size 05)
- Connections:** GAS BSP (UNI ISO 228/1)
- Integrated mechanical displacement limiter as standard on all pumps**
- Set-up for combined pumps on request**
- Wide choice of pressure and flow regulation controls**

Series/Name	Rated Displacement (cm ³ /r [in ³ /r])	Maximum Flow Capacity at 1450 rpm (L/min) [US gpm]	Maximum Pressure (bar) [psi]
01-PHV-05-16	from 4 [0.24] to 16 [0.98]	from 6 [1.59] to 23 [6.08]	250 [3626]
01-PHV-1-32	from 8 [0.49] to 32 [1.95]	from 12 [3.17] to 47 [12.41]	250 [3626]

CONTENTS

GENERAL DESCRIPTION B-3

TECHNICAL DATA B-4

ORDERING CODE B-5

CHARACTERISTIC CURVES..... B-6

DIMENSIONS B-7

PRESSURE FLOW-RATE CONTROLS B-9

COMBINED PUMPS..... B-19

SETTINGS B-22

INSTRUCTIONS FOR INSTALLATION AND USE B-23

ASSEMBLY B-25

WARNING

All Berarma pumps have been carefully checked during manufacture and subjected to stringent testing cycles before shipment. To achieve optimum performance, avoid problems and maintain the warranty, the installation instructions enclosed with each pump must be strictly observed.

NOTES

Before selection or use of any Berarma product, it is important that the purchaser analyses all aspects of its application and reviews the information in the current Berarma Technical-Sales catalogues. Due to the many different operating conditions and applications for Berarma products, the purchaser, through their own analysis and testing, is solely responsible for making the final selection of the products and assuring that all performance and safety requirements are met.

Berarma S.r.l. accepts no responsibility for any editing mistakes in this catalogue.
Berarma S.r.l. reserves the right to modify these data without prior notice.

GENERAL DESCRIPTION

As a result of the constant research carried out in order to introduce innovative products to the market characterised by high technological content and reliability, BERARMA has launched the **new series of HIGH PRESSURE variable displacement vane pumps, known as 01 PHV.**

The new series of 01 PHV pumps combines the characteristics of other BERARMA variable displacement vane pumps

- SILENT RUNNING
- HIGH EFFICIENCY
- LONG WORKING LIFE
- ECONOMY AND SIMPLIFICATION OF HYDRAULIC SYSTEM
- MODULAR DESIGN
- ENERGY SAVING

with significant improvements in performance due to

- **HIGH WORKING PRESSURE**
- **EXCELLENT DYNAMICS OF DISPLACEMENT CONTROL**

The main innovation of the new series of 01 PHV pumps is the internal pump cartridge, designed to obtain perfect axial balancing, both in terms of hydrostatic compensation of the distribution plates and the fluid flow-rate from inlet to outlet.

The new series of 01 PHV pumps is supplied with:

- ISO standard MOUNTING FLANGES
- GAS BSP standard PORT CONNECTIONS
- flow regulator unit to mechanically reduce pump displacement
- various types of hydraulic, electrical and proportional adjustment devices in order to control the pump flow-rate and/or pressure
- (on request only) set-up for coupling to all BERARMA pumps or to the main others types of pump available on the fluid power market.

Considering the features outlined above, the new series of 01 PHV pumps is one of a kind, suitable for applications that require higher performances than the standard use of variable vane pumps.

What makes the new BERARMA 01 PHV series of pumps unique?

- 250 bar [3626 psi] working pressure
- DUAL INLET AND OUTLET CHANNELS in the internal pump cartridge
- DUAL AXIAL HYDROSTATIC BALANCING on the distribution plates
- "FORCED" HYDRODYNAMIC LUBRICATION on journal bearings
- NEW FUNCTIONAL DESIGN OF THE PRESSURE COMPENSATOR DEVICE (reduction in pressure overshoots and pressure stabilization time)
- REDUCTION IN WEAR on internal pump cartridge parts
- INNOVATIVE SHAPES AND DESIGN

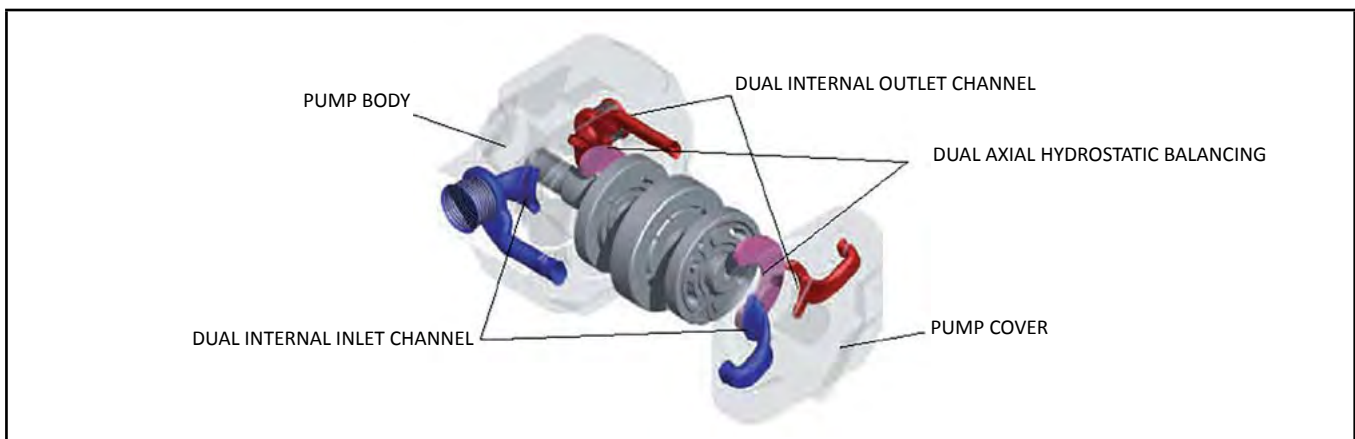

TECHNICAL DATA

NOMINAL SIZE		SIZE 05	SIZE 1
Geometric displacement according to UNI ISO 3662 (cm ³ /r) [in ³ /r]		16 [0,976]	32 [1,953]
Actual displacement (cm ³ /r) [in ³ /r]		17.9 [1,092]	34.5 [2,105]
Due to manufacturing tolerances, the value can vary by approx. ±3%			
Maximum working pressure (bar) [psi]		250 [3626]	
Pressure peak exceeding 30% of the maximum operating pressure must be eliminated by adopting the appropriate measures.			
Control pressure setting (bar) [psi]		H: 20 ÷ 250 [290 ÷ 3626]	
Mounting flange and port connections see description on pag. 7÷8		F - FGR2	F
Permitted maximum drain port pressure (bar) [psi]		1 [14.5]	
Inlet pressure (bar) [psi]		0.8 ÷ 1.5 [11.6 ÷ 21.8] absolute	
Speed range (rpm)		800 ÷ 1800	
Rotation direction (viewed from shaft end)		R - Right	
Loads on drive shaft		NO RADIAL OR AXIAL LOADS ALLOWED	
Maximum torque on primary shaft (Nm) [lb in]	Tmax	130 [1150]	250 [2212]
Hydraulic fluid		HM hydraulic oil according to ISO 6743/4; HLP hydraulic oil according to DIN 5124/2 for other fluids contact Berarma Technical-Sales Service	
Viscosity range (cSt, mm ² /s)		22 - 68 at operating temperature	
Starting viscosity under full flow conditions (cSt, mm ² /s)		400 max	
Viscosity index according to ISO 2909		100 min	
Inlet fluid temperature range (°C) [°F]		+15 / +60 [14 / 140]- pay attention to viscosity range	
Maximum acceptable fluid contamination level		20/18/15 according to ISO 4406/99, CLASS 9 according to NAS 1638	
Recommended fluid contamination level for a longer pump working life		18/16/13 according to ISO 4406/99, CLASS 7 according to NAS 1638	
Moment of inertia (kgm ²)		0.00019	0.00075
Single pump weight (kg) [lb]			
Single stage pressure compensator		16.5 [36.5]	27.0 [59.5]
PCS002		18.5 [41.0]	29.0 [64.0]
PCS003		18.0 [40.0]	28.5 [63.0]
PCS004		19.0 [42.0]	30.0 [66.0]
PCS005		18.0 [40.0]	28.5 [63.0]
PCLS001		19.0 [42.0]	29.5 [65.0]
PCLS002		19.5 [43.0]	30.0 [66.0]
PCLS003		19.0 [42.0]	29.5 [65.0]
PCLS004		20.0 [44.0]	30.5 [67.0]
PCLS005		19.0 [42.0]	29.5 [65.0]
For further information and/or different operating conditions, please contact Berarma Technical-Sales Service			

ORDERING CODE

SERIES	NAME	SIZE	DISPLACEMENT	FLANGE	PRESSURE SETTING	ROTATION	SEALS	COMBINED PUMPS	PRESSURE / FLOW CONTROLS
01	PHV	05 - 16	F	H	R	M	A	PCS...	

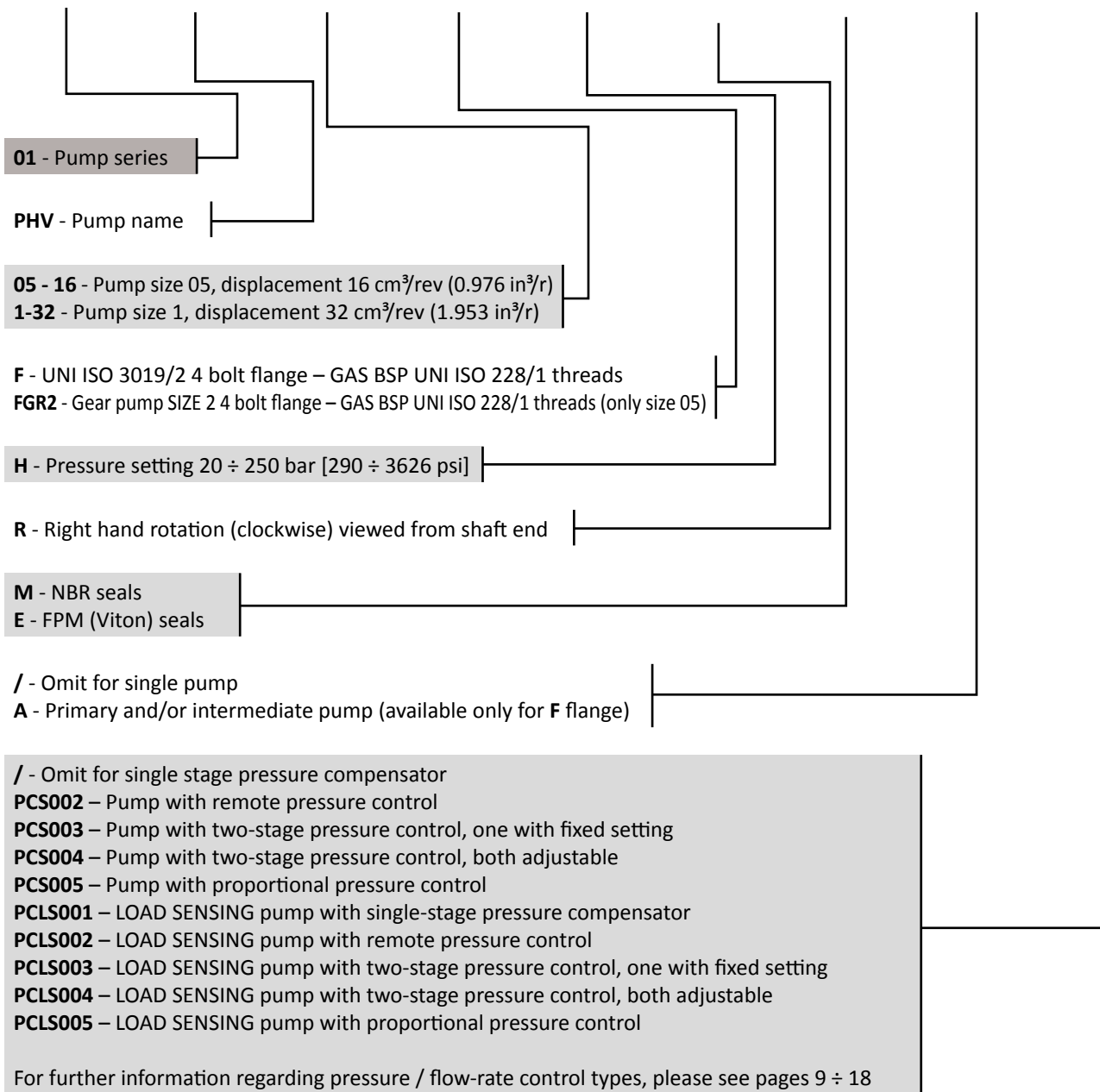

ORDERING CODE

CHARACTERISTIC CURVES

Indicative values measured on Berarma test machine, referring to 1500 rpm, with HM hydraulic oil according to ISO 6743/4, ISO VG 32 according to ISO 3448, temperature 48°C [118°F].

01 PHV 05-16 FHRM

01 PHV 1-32 FHRM

Volumetric efficiency – zero flow setting curve

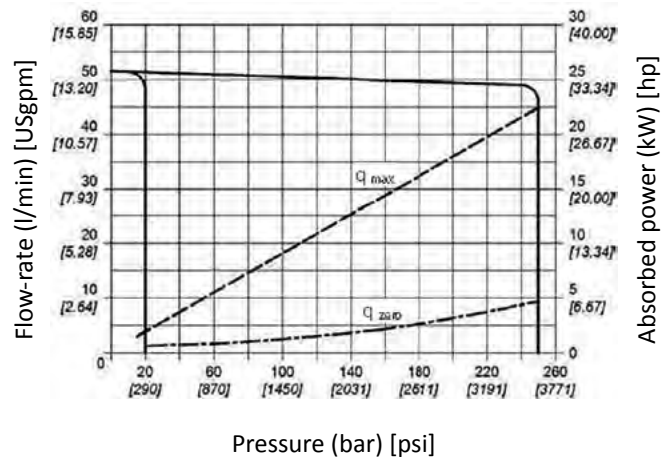
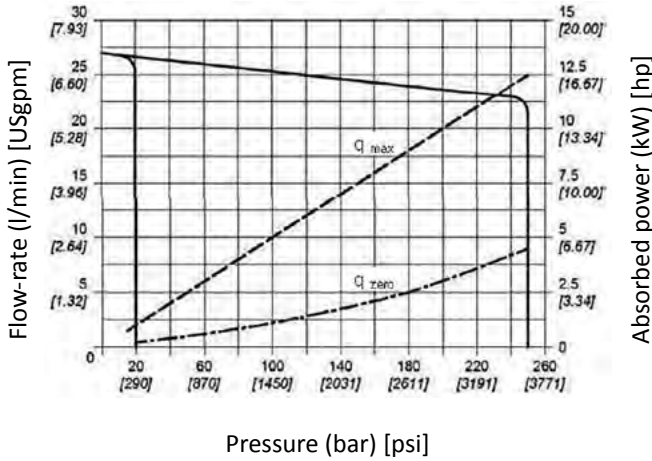

Noise level

Indicative maximum noise level values measured with sound-level meter placed one metre [39.370"] from the pump, with flexible coupling

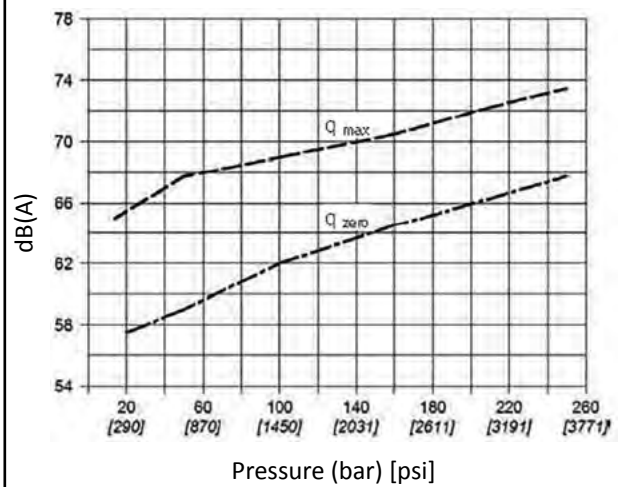
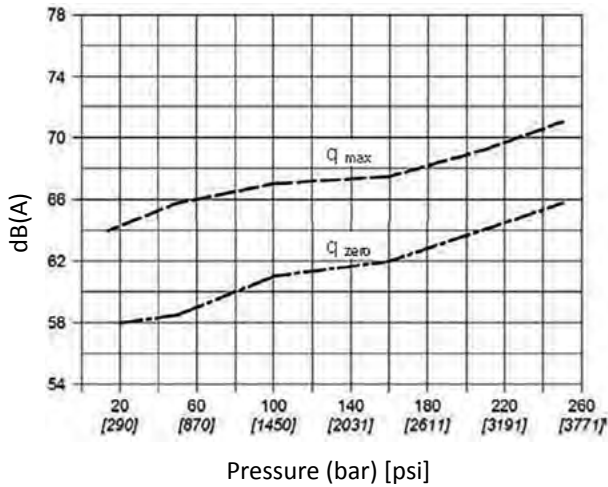

Case drain (leakage) flow-rate

Pump under zero flow setting conditions

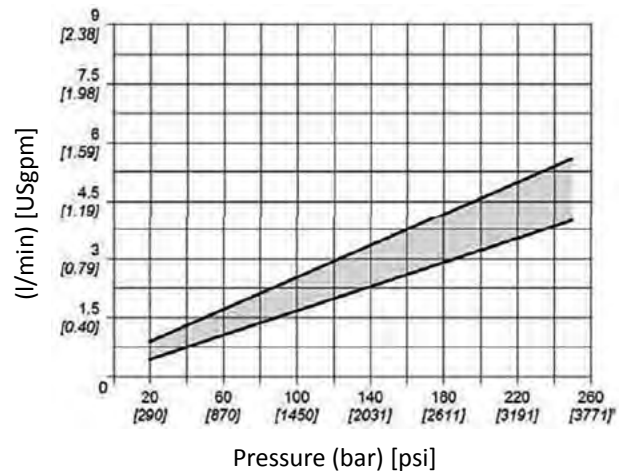
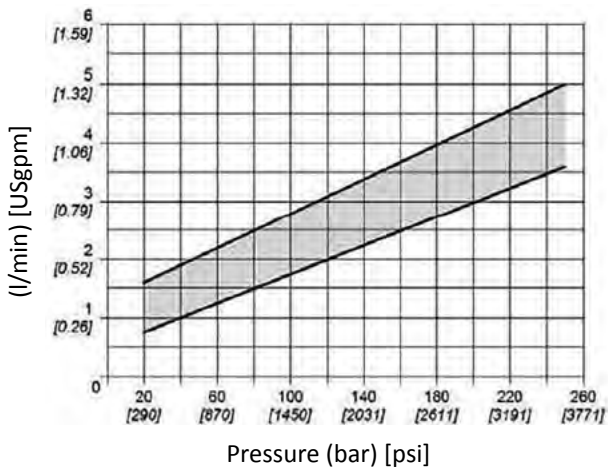

DIMENSIONS

DIMENSIONS

01 PHV 05 16 FHRM

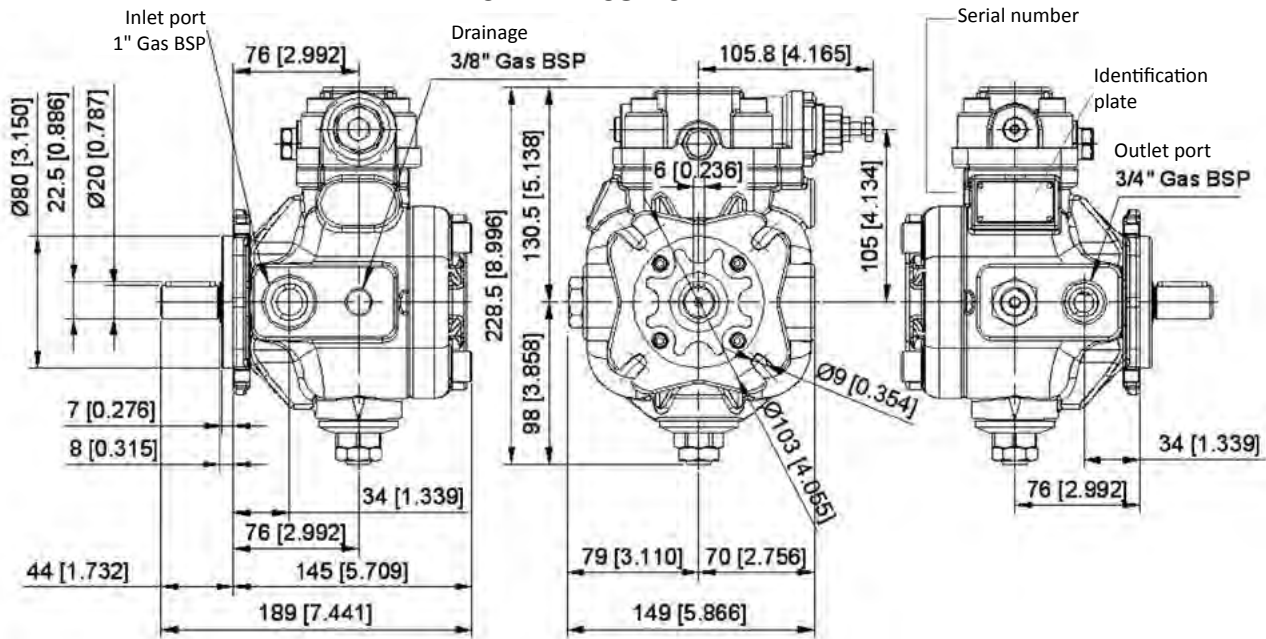

Dimensions inside [] are in inches

THRU-DRIVE SHAFT (-A)

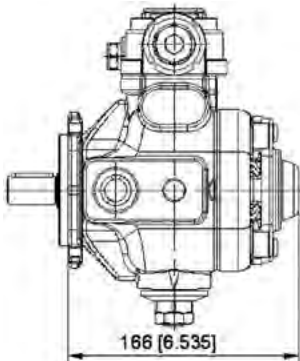

For combined pump solutions, please see pages 19÷21
Dimensions inside [] are in inches

FGR2 FLANGE AND SHAFT (not available on -A version)

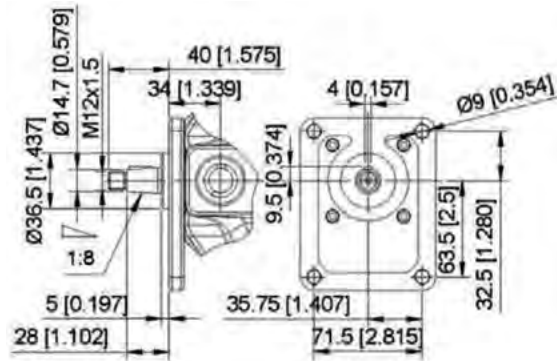

Dimensions inside [] are in inches

Mounting surface ISO 4401-03 (CETOP 03) for pressure/flow-rate controls PCS 003/004 and PCLS 003/004 (pages 11, 12, 16, 17)

Designation	Dimension
C	40.5 [1,594]
D	21.5 [0,846]
E	12.7 [0,500]
F	0.75 [0,030]
G	5.1 [0,201]
H	15.5 [0,610]
J	25.9 [1,020]
K	31 [1,220]
L	31.75 [1,250]

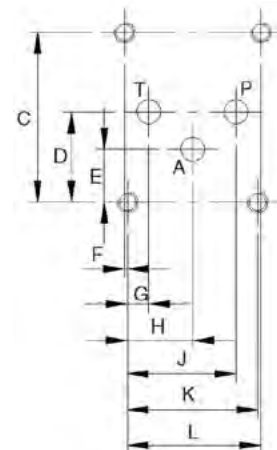

Dimensions inside [] are in inches

Note: "A" port is available only for PCS004 and PCLS004 controls

DIMENSIONS

01 PHV 1 32 FHRM

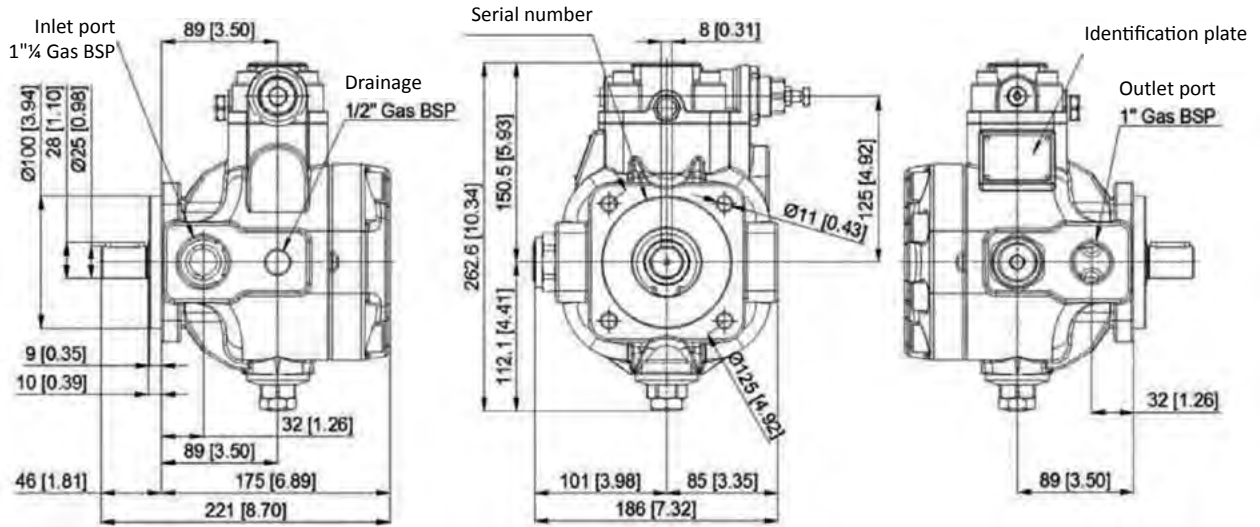

Dimensions inside [] are in inches

THRU-DRIVE SHAFT (-A)

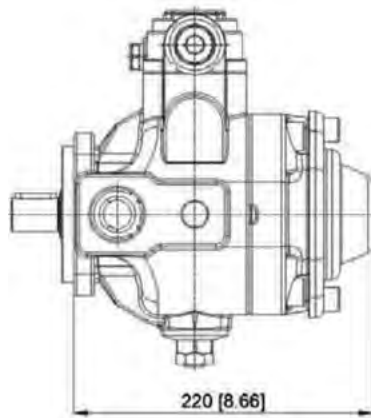

For combined pump solutions, please see pages 19÷21

Dimensions inside [] are in inches

Mounting surface ISO 4401-03 (CETOP 03) for pressure/flow-rate controls PCS 003/004 and PCLS 003/004 (pages 11, 12, 16, 17)

Designation	Dimension
C	40.5 [1,594]
D	21.5 [0,846]
E	12.7 [0,500]
F	0.75 [0,030]
G	5.1 [0,201]
H	15.5 [0,610]
J	25.9 [1,020]
K	31 [1,220]
L	31.75 [1,250]

Note: "A" port is available only for PCS004 and PCLS004 controls

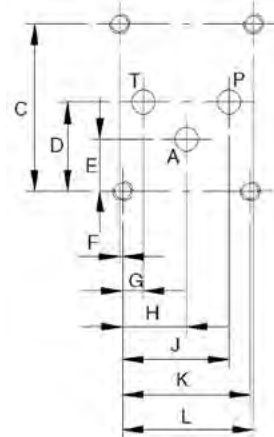

Dimensions inside [] are in inches

PRESSURE FLOW-RATE CONTROLS

STANDARD CONTROL

Hydraulic single-stage pressure control.

This standard control enables the pump displacement to be adjusted (until “zero flow setting” condition) according to the flow-rate required by the hydraulic system, keeping the working pressure constant and equal to the value set on the compensator device.

The pressure setting of the compensator device is adjusted by means of the “SP” pressure setting screw and locked using the corresponding locknut.

Properties	
Pressure setting range	20 – 250 bar [290 – 3626 psi]

Pressure setting	
Pressure setting screw	CH 13 mm HEX
Pressure setting locknut	CH 13 mm HEX
Clockwise rotation increases the pressure setting	

Control Devices	
"U"	Standard pressure compensator device

Ports	
"AB" – Air Bleed	1/4" Gas BSP ■
■	Supplied port closed

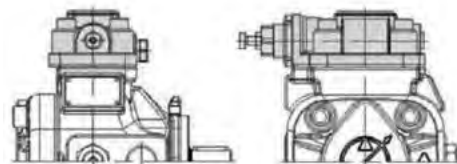
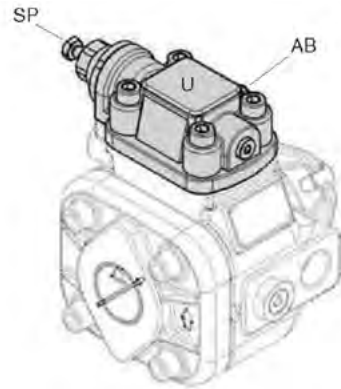
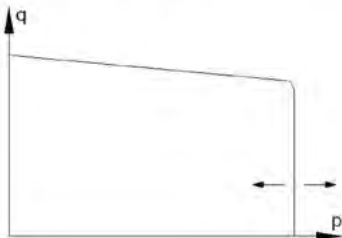
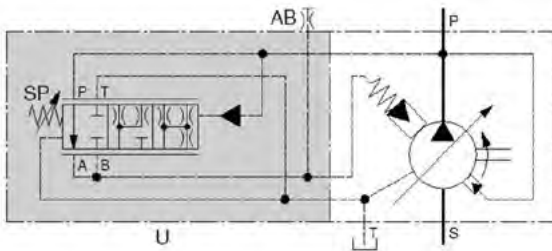

For overall dimensions please see pages 7÷8

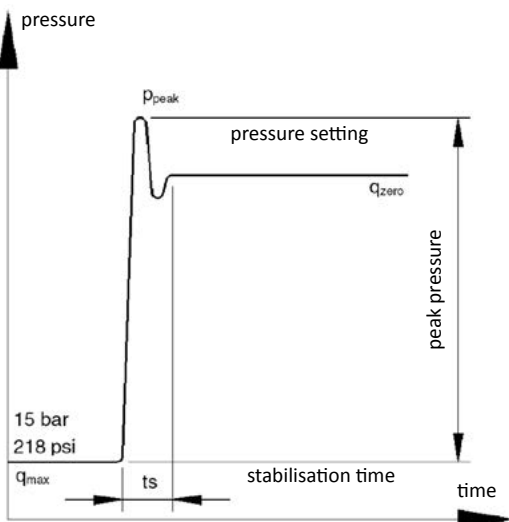

Dynamic characteristics of pressure compensator device				
Test: full flow → zero flow setting condition				
Pump type	15 → 210 bar [218 → 3046 psi]		15 → 250 bar [218 → 3626 psi]	
	p _{peak}	t _s	p _{peak}	t _s
01 PHV 05	250bar [3626psi]	50ms	285bar [4134psi]	40ms
01 PHV 1	270bar [3915psi]	80ms	320bar [4640psi]	60ms

Testing conditions on Berarma test machine:

- Dynamic response curves obtained by suddenly closing the pump pressure line with a rapid shut-off valve mounted about 0.5 m [19.685"] from the pump outlet port
- HM hydraulic fluid according to ISO 6743/4, ISO VG32 according to ISO 3448, temperature 48°C (118°F), 1500 rpm
- **PRESSURE PEAKS EXCEEDING 30% OF THE MAXIMUM OPERATING PRESSURE MUST BE ELIMINATED**

PCS002 CONTROL

Hydraulic control with remote pressure setting.

The function of this control is the same as the standard control function with the addition of the possibility of adjusting the working pressure by means of an additional maximum pressure relief valve "RV" installed in a remote position, far from the pump.

Control performances depends on the additional valve type and on its distance from the pump.

Properties	
Pressure setting range	20 – 250 bar [290 – 3626 psi]

Control Devices	
"U1"	Pressure compensator device for additional controls
"SM"	"Minimum pressure" spring adjustment (factory preset at 20bar [290psi] – do not tamper)
"W"	Maximum pressure relief valve (factory preset at maximum value 250bar [3623psi])
"R"	Remote control block
"RV"	Additional remote maximum pressure relief valve (Properties: 0÷5 l/min [0÷1.32 USgpm]) (not supplied)

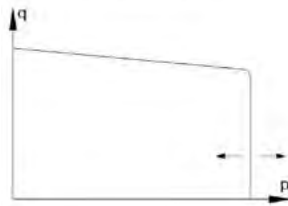
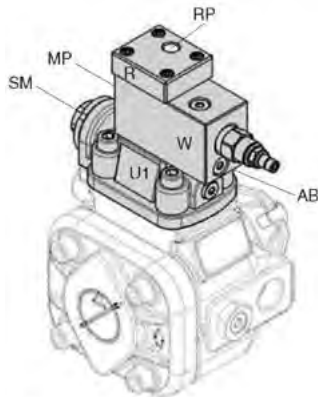

Ports	
"AB" – Air Bleed	1/4" Gas BSP ■
"MP" Pressure gauge	1/4" Gas BSP ■
"RP" Remote control port	1/4" Gas BSP □
The pilot pipe length between the pump and the additional valve "RV" must not exceed 5m [16 ft].	
□	Must be connected
■	Supplied port closed

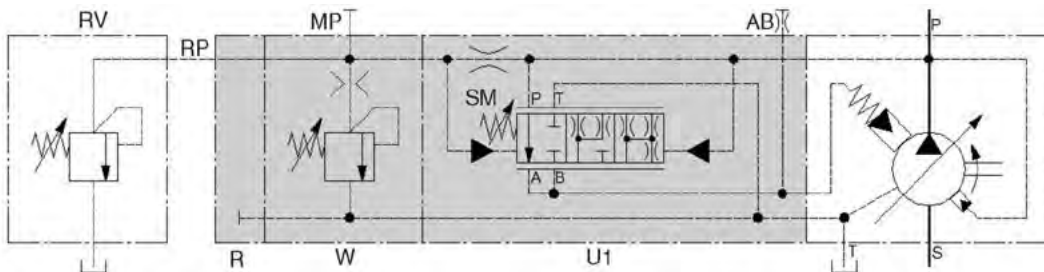

Designation	Dimensions	
	SIZE 05	SIZE 1
J	66 [2,598]	79 [3,110]
K	203 [7,992]	223 [8,780]
L	1.3 [0,051]	1.3 [0,051]
M	81 [3,189]	85 [3,346]
N	117 [4,606]	117 [4,606]

Indicative dimensions. For further information please contact Berarma Technical-Sales Service.
Dimensions inside [] are in inches.

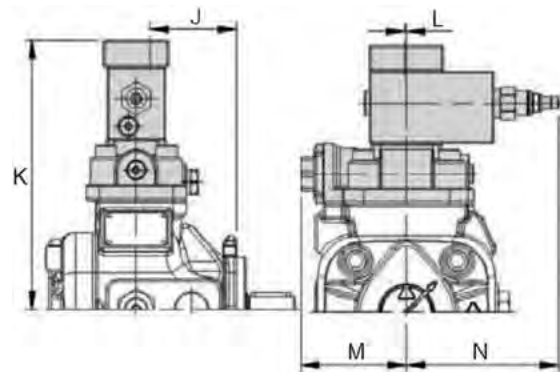

PCS003 CONTROL

Hydraulic two-stage pressure control, one with fixed setting.

The function of this control is the same as the standard control with the addition of the option to mount a directional control valve "EV" on the top of the compensator in order to switch between two working pressure levels, one of which is fixed. Control performance depends on the type of additional directional control valve.

Properties	
1st pressure level	Factory fixed preset at 20bar [290psi] – Do not tamper
2nd adjustable pressure level	20 – 250 bar [290 – 3626 psi]

Control Devices	
"U1"	Pressure compensator device for additional controls
"SM"	"Minimum pressure" spring adjustment (1st fixed pressure setting level) Do not tamper
"W"	Maximum pressure relief valve (2nd adjustable pressure setting level)
"EV"	Directional control valve (supplied only on request) For information please contact Berarma Technical-Sales Service

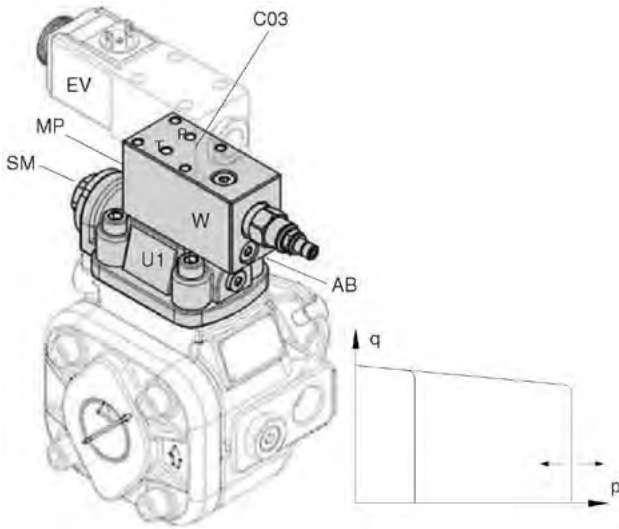

Ports	
"AB" – Air Bleed	1/4" Gas BSP ■
"MP" Pressure gauge	1/4" Gas BSP ■
Surface – "C03" (See pages 7÷8)	ISO 4401-03 (CETOP 03) □
■	Supplied port closed
□	Must be connected

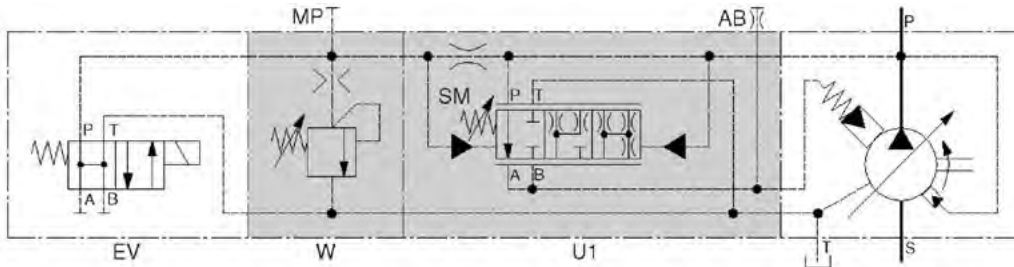

Designation	Dimensions	
	SIZE 05	SIZE 1
J	(*)	(*)
K	183 [7,205]	203 [7,992]
L	(*)	(*)
M	81 [3,189]	85 [3,346]
N	117 [4,606]	117 [4,606]

(*): Please consult the directional control valve catalogue Indicative dimensions. For further information please contact Berarma Technical-Sales Service.
Dimensions inside [] are in inches.

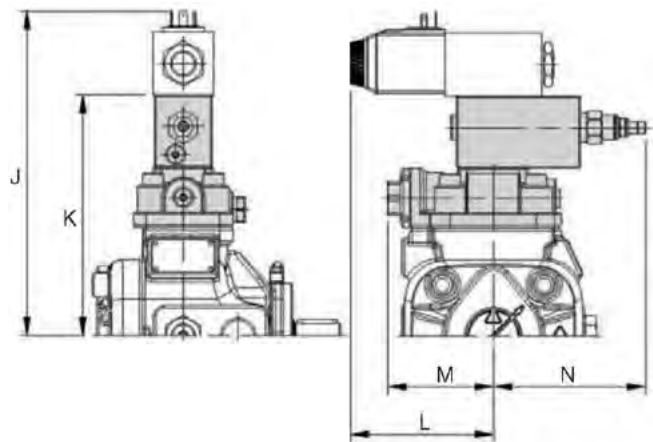

PRESSURE / FLOW-RATE CONTROLS

PCS004 CONTROL

Hydraulic two-stage pressure control, both adjustable.

The function of this control is the same as the standard control with the addition of the option to mount a directional control valve "EV1" on the top of the compensator in order to switch between two adjustable working pressure levels.

Control performance depends on the type of additional directional control valve.

Properties	
1st adjustable pressure level	20 – 250 bar [290 – 3626 psi]
2nd adjustable pressure level	20 – 250 bar [290 – 3626 psi]
Note: 1st adjustable pressure level < 2nd adjustable pressure level	

Control Devices	
"U1"	Pressure compensator device for additional controls
"SM"	"Minimum pressure" spring adjustment (factory preset at 20bar [290psi] – do not tamper)
"W1"	Maximum pressure relief valve block "MIN" 1st adjustable pressure level "MAX" 2nd adjustable pressure level
"EV1"	Directional control valve (supplied only on request) For information please contact Berarma Technical-Sales Service.

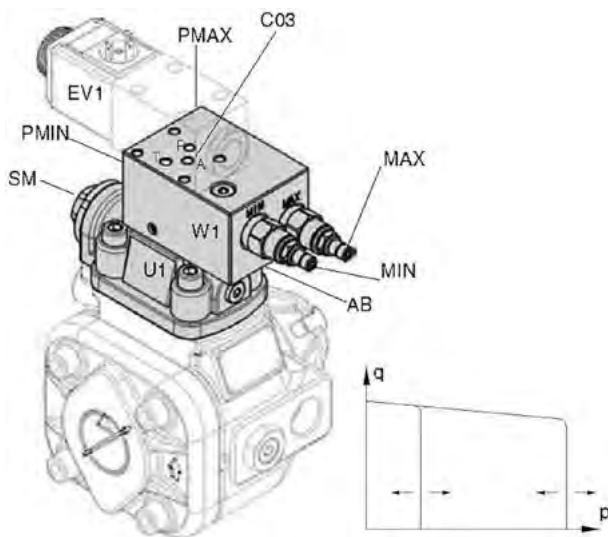

Ports	
"AB" – Air Bleed	1/4" Gas BSP ■
Pressure gauges	"PMIN" "PMAX" 1/4" Gas BSP ■
Surface – "C03" (See pages 7÷8)	ISO 4401-03 (CETOP 03) □
■	Supplied port closed
□	Must be connected

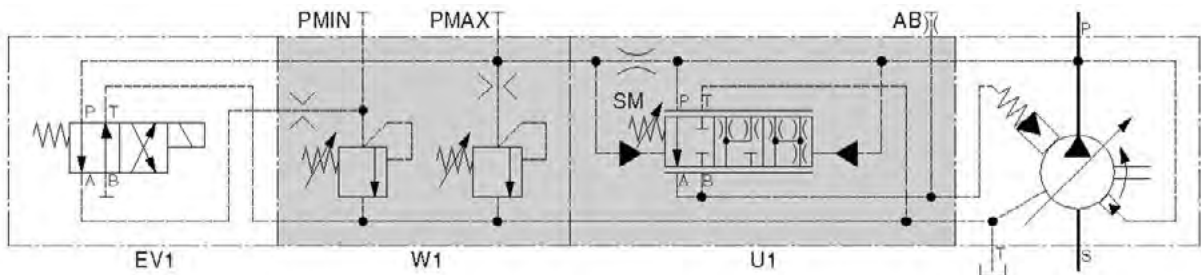

Designation	Dimensions	
	SIZE 05	SIZE 1
J	(*)	(*)
K	183 [7,205]	203 [7,992]
L	(*)	(*)
M	81 [3,189]	85 [3,346]
N	117 [4,606]	117 [4,606]

(*): Please consult the directional control valve catalogue Indicative dimensions. For further information please contact Berarma Technical-Sales Service.
Dimensions inside [] are in inches.

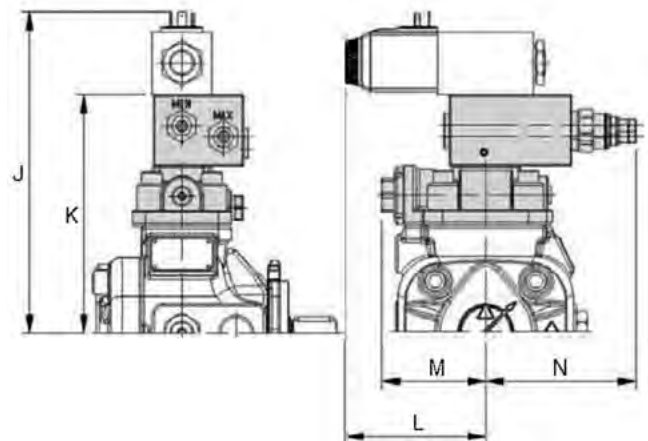

PCS005 CONTROL

Hydraulic control with proportional pressure adjustment.

This control, with integrated proportional valve "W2" mounted on top of the compensator, enables the pump working pressure to be adjusted proportionally by means of an electrical signal.

Control performance depends on the type of electronic control unit for the proportional valve (**unit supplied on request only**).

Properties	
Pressure setting range	20 – 250 bar [290 – 3626 psi]

Electrical properties	
Voltage	24 VDC ±10%
Maximum current	590 mA
Power consumption	22 Watt
Nominal coil resistance at 50°C [122°F]	37.2 Ω ±5%
Nominal coil resistance at 20°C [68°F]	26.2 Ω ±5%
Maximum coil temperature at 20°C [68°F]	105°C [218°F]
Protection class	IP65
Recommended Dither frequency	160 – 200 Hz (*)
Linearity, Hysteresis, Repeatability	< 5% (*)
Connector	ISO/DIN 43650, Form A

(*): Depends on electronic control unit for the proportional valve
For available electronic control unit types, please contact Berarma Technical-Sales Service.

Control Devices	
"U1"	Pressure compensator device for additional controls
"SM"	"Minimum pressure" spring adjustment (factory preset at 20bar [290psi] do not tamper)
"W2"	Proportional maximum pressure relief valve

Ports	
"AB" – Air Bleed	1/4" Gas BSP ■
"MP" Pressure gauge	1/4" Gas BSP ■
■	Supplied port closed

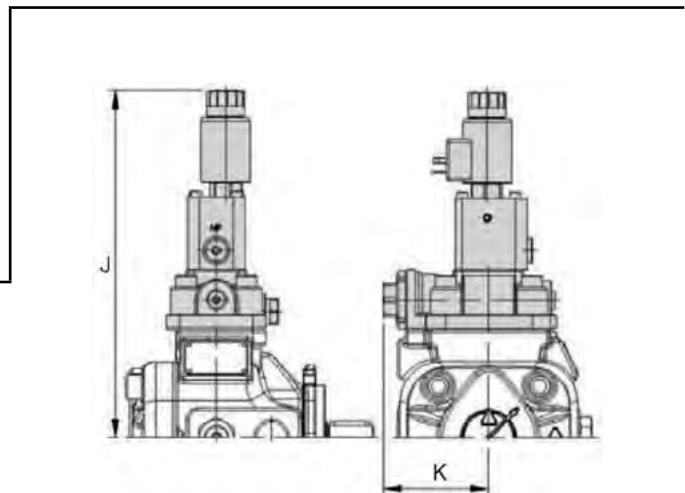
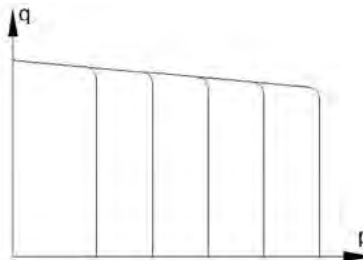
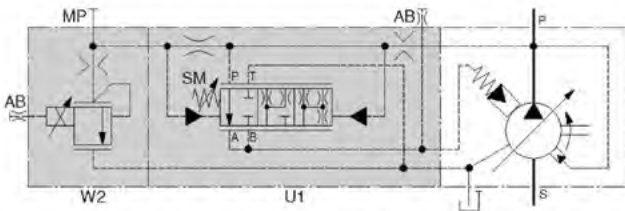
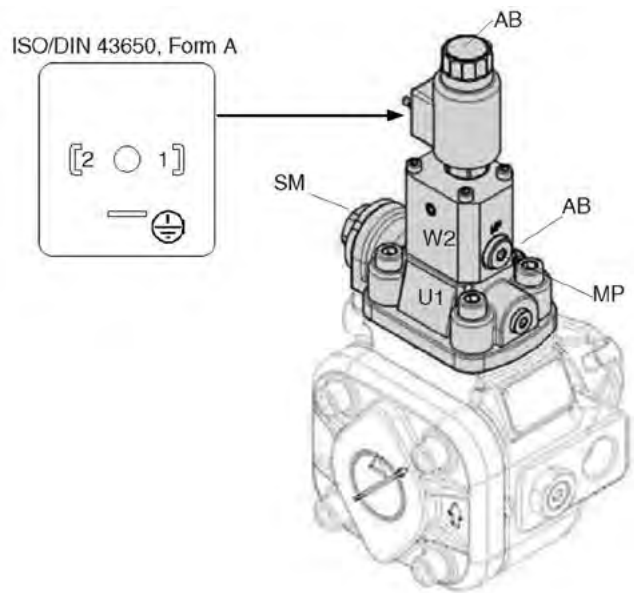

Designation	Dimensions	
	SIZE 05	SIZE 1
J	272 [10,709]	292 [11,496]
K	81 [3,189]	85 [3,346]

Indicative dimensions. For further information please contact Berarma Technical-Sales Service.
Dimensions inside [] are in inches.

PCLS001 CONTROL

Hydraulic control with Load Sensing device and single-stage pressure control.

The Load Sensing control system adds to the pressure setting adjustment system of the compensator device the option of regulating the pump flow-rate according to the pressure difference Δp measured on either side of a throttle valve.

The pilot pressure of the Load Sensing compensator device is taken from the pump outlet line after throttle "Z" (manually or electronically operated) and before the actuators. Changing the position of the throttle, with a fixed pressure drop equal to the "differential pressure Δp " value, the Load Sensing system automatically adjusts the pump displacement independently of pressure variations that occur in the hydraulic system.

The Load Sensing control produces a notable reduction in displaced power and is recommended for use in applications where there are significant variations in torque (force) and speed.

In the PCLS001 control system, the adjustment of the single-stage pressure setting of the compensator device occurs by means of the maximum pressure relief valve "W".

Note: when the throttle valve "Z" is completely closed, the pump will be in "zero flow setting condition", keeping the working pressure constant and equal to the "differential pressure Δp " value.

Control performance depends on the type of throttle valve "Z" and on the length / dimensions of the Load Sensing pilot pressure line

Ports	
"AB" – Air Bleeds	1/4" Gas BSP ■
"MP" Pressure gauge	1/4" Gas BSP ■
"LS" Load Sensing port	1/4" Gas BSP □
The length between the throttle and the Load Sensing port must not exceed 5m [16ft].	
■	Supplied port closed
□	Must be connected

Properties	
Pressure setting range	20 – 250 bar [290 – 3626 psi]
Differential pressure Δp	≥ 20 bar [≥ 290 psi]

Control Devices	
"U2"	Load Sensing pressure compensator device
"SD"	Differential pressure Δp adjustment
"W"	Maximum pressure relief valve
"V"	Load Sensing Block
"Z"	Throttle (manual or electronic) (not supplied)

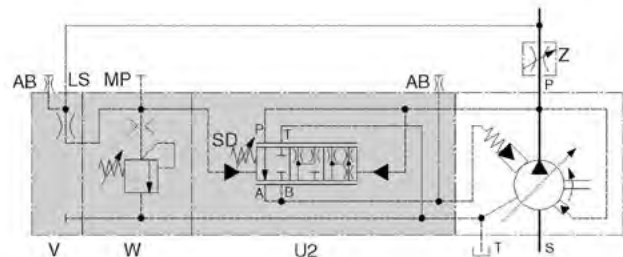
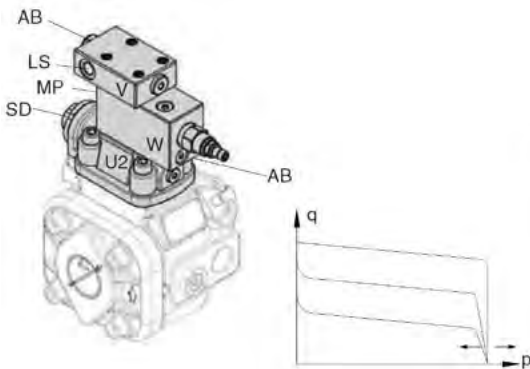

Designation	Dimensions	
	SIZE 05	SIZE 1
J	105 [4,134]	118 [4,646]
K	211 [8,307]	231 [9,094]
L	197 [7,756]	217 [8,543]
M	32 [1,260]	32 [1,260]
N	117 [4,606]	117 [4,606]
Q	81 [3,189]	85 [3,346]

Indicative dimensions. For further information please contact Berarma Technical-Sales Service.
Dimensions inside [] are in inches.

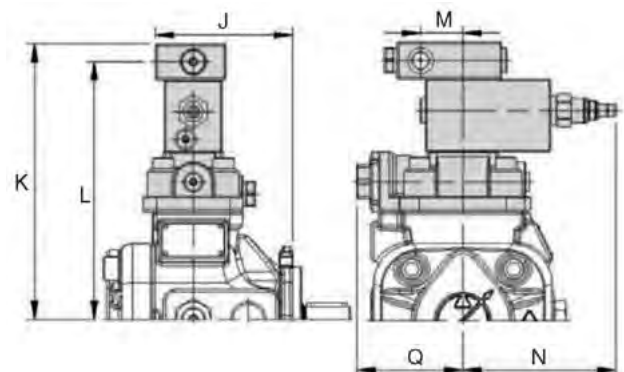

PCLS002 CONTROL

Hydraulic control with Load Sensing device and remote pressure setting.

The function of this control is the same as the standard control function with the addition of the possibility of adjusting the working pressure by means of an additional maximum pressure relief valve "RV" installed in a remote position, far from the pump.

Control performance depends on type of throttle valve "Z", on the length

/ dimensions of the Load Sensing pilot pressure line, on the type of additional valve "RV", and on its distance from the pump.

Properties	
Pressure setting range	20 – 250 bar [290 – 3626 psi]
Differential pressure Δp	≥ 20 bar [≥ 290 psi]

Ports	
"AB" – Air Bleeds	1/4" Gas BSP ■
"MP" Pressure gauge	1/4" Gas BSP ■
"LS" Load Sensing port	1/4" Gas BSP □
The length between the throttle and the Load Sensing port must not exceed 5m [16ft].	
"RP" Remote control port	1/4" Gas BSP □
The length of the remote pilot pipe between the pump and the additional valve "RV" must not exceed 5m [16 ft].	
■	Supplied port closed
□	Must be connected

Control Devices	
"U2"	Load Sensing pressure compensator device
"SD"	Differential pressure Δp adjustment
"W"	Maximum pressure relief valve (factory preset at maximum value 250bar [3623psi])
"V1"	Load Sensing Block for additional controls
"R"	Remote control block
"Z"	Throttle (manual or electronic) (not supplied)
"RV"	Additional remote maximum pressure relief valve (Properties: 0 ÷ 5 l/min [0 ÷ 1.32 USgpm] (not supplied))

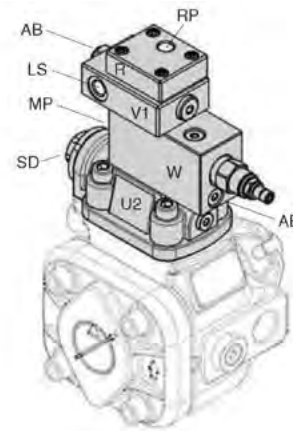
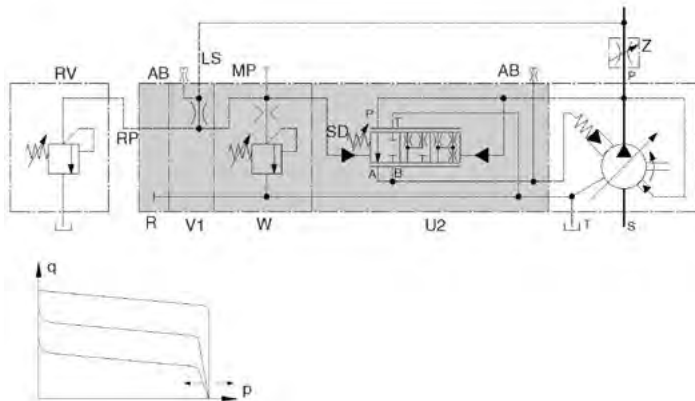

Designation	Dimensions	
	SIZE 05	SIZE 1
G	105 [4,134]	118 [4,646]
H	66 [2,598]	79 [3,110]
J	231 [9,094]	251 [9,882]
K	197 [7,756]	217 [8,543]
L	32 [1,260]	32 [1,260]
M	1.3 [0,051]	1.3 [0,051]
N	117 [4,606]	117 [4,606]
Q	81 [3,189]	85 [3,346]

Indicative dimensions. For further information please contact Berarma Technical-Sales Service.
Dimensions inside [] are in inches.

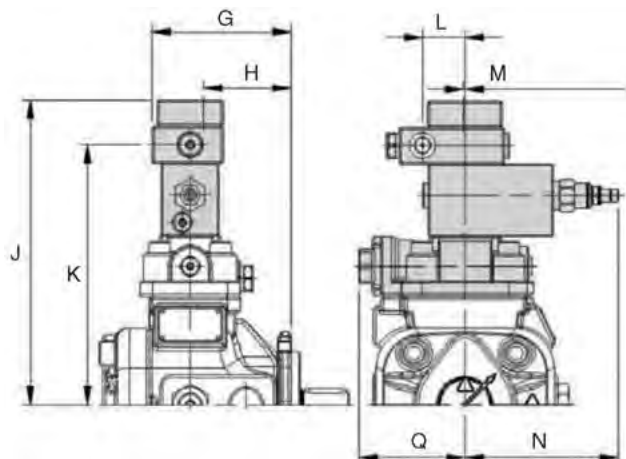

PCLS003 CONTROL

Hydraulic control with Load Sensing device and two-stage pressure control, one with fixed setting.

The function of this control is the same as the Load Sensing standard control with the addition of the option to mount a directional control valve "EV" on the top of the compensator in order to switch between two working pressure levels, one of which is fixed. Control performance depends on the type of throttle valve "Z", on the length / dimensions of the Load Sensing pilot pressure line, and on the type of additional directional control valve

Properties	
Differential pressure Δp (1st pressure level)	PFixed preset at ≥ 20 bar [≥ 290 psi]
2nd adjustable pressure level	20 – 250 bar [290 – 3626 psi]
Ports	
"AB" – Air Bleeds	1/4" Gas BSP ■
"MP" Pressure gauge	1/4" Gas BSP ■
"LS" Load Sensing port	1/4" Gas BSP □
The length between the throttle and the Load Sensing port must not exceed 5m [16ft].	
Surface – "C03" (See pages 7÷8)	ISO 4401-03 (CETOP 03) □
■	Supplied port closed
□	Must be connected

Control Devices	
"U2"	Load Sensing pressure compensator device
"SD"	Differential pressure Δp adjustment (1st fixed pressure setting level)
"W"	Maximum pressure relief valve (2nd adjustable pressure setting level)
"V1"	Load Sensing Block for additional controls
"EV"	Directional control valve (supplied only on request) For information please contact Berarma Technical-Sales Service
"Z"	Throttle (manual or electronic) (not supplied)

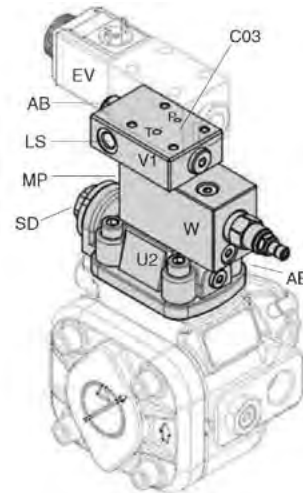
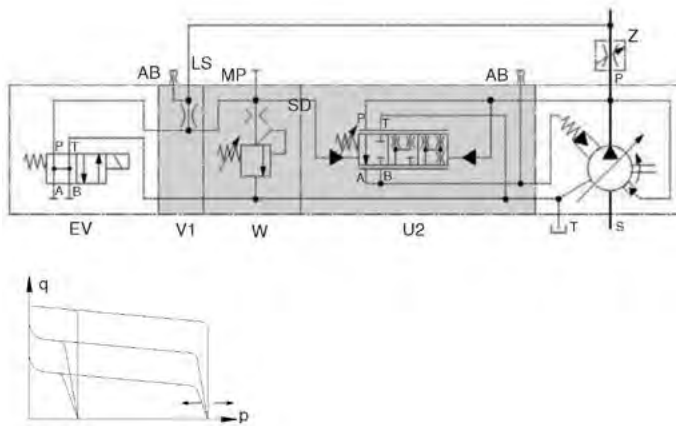

Designation	Dimensions	
	SIZE 05	SIZE 1
J	105 [4,134]	118 [4,646]
K	(*)	(*)
L	211 [8,307]	231 [9,094]
M	197 [7,756]	217 [8,543]
N	32 [1,260]	32 [1,260]
Q	(*)	(*)
R	117 [4,606]	117 [4,606]

(*): Please consult the directional control valve catalogue Indicative dimensions. For further information please contact Berarma Technical-Sales Service.
Dimensions inside [] are in inches.

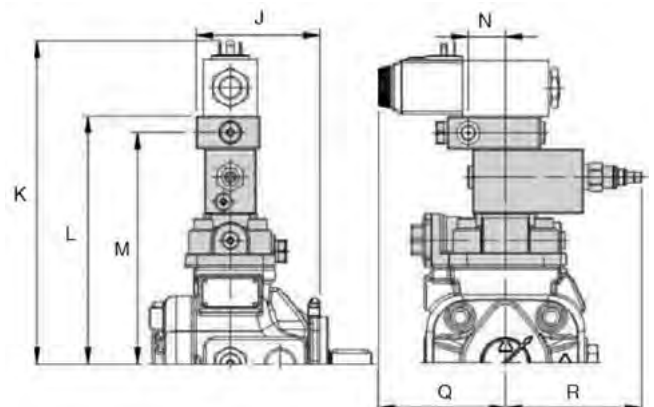

PCLS004 CONTROL

Hydraulic control with Load Sensing device and two-stage pressure control, both adjustable.

The function of this control is the same as the Load Sensing standard control with the addition of the option to mount a directional control valve "EV1" on the top of the compensator in order to switch between two adjustable working pressure levels.

Control performance depends on the type of throttle valve "Z", on the length / dimensions of the Load Sensing pilot pressure line, and on the type of additional directional control valve.

Properties	
1st adjustable pressure level	20 – 250 bar [290 – 3626 psi]
2nd adjustable pressure level	20 – 250 bar [290 – 3626 psi]
Note: 1st adjustable pressure level < 2nd adjustable pressure level	
Differential pressure Δp	≥ 20 bar [≥ 290 psi]

Ports	
"AB" – Air Bleeds	1/4" Gas BSP ■
Pressure gauges	"PMIN" "PMAX" 1/4" Gas BSP ■
"LS" Load Sensing port	1/4" Gas BSP □
The length between the throttle and the Load Sensing port must not exceed 5m [16ft].	
Surface – "C03" (See pages 7÷8)	ISO 4401-03 (CETOP 03) □
■	Supplied port closed
□	Must be connected

Control Devices	
"U2"	Load Sensing pressure compensator device
"SD"	Differential pressure Δp adjustment
"W1"	Maximum pressure relief valve block "MIN" 1st adjustable pressure level "MAX" 2nd adjustable pressure level
"V1"	Load Sensing Block for additional controls
"EV1"	Directional control valve (supplied only on request) For information please contact Berarma Technical-Sales Service
"Z"	Throttle (manual or electronic) (not supplied)

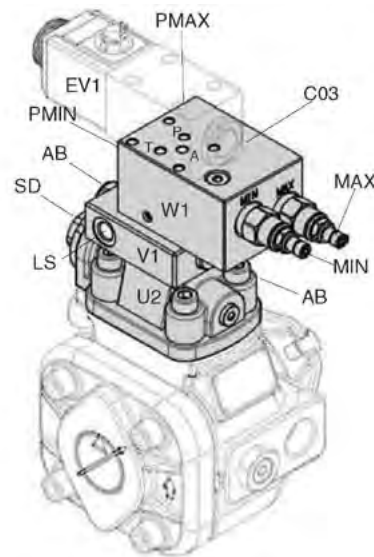
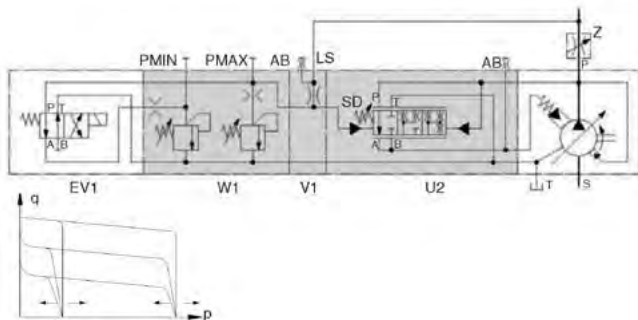

Designation	Dimensions	
	SIZE 05	SIZE 1
J	105 [4,134]	118 [4,646]
K	(*)	(*)
L	211 [8,307]	231 [9,094]
M	142 [5,591]	162 [6,378]
N	32 [1,260]	32 [1,260]
Q	(*)	(*)
R	117 [4,606]	117 [4,606]

(*): Please consult the directional control valve catalogue Indicative dimensions. For further information please contact Berarma Technical-Sales Service.
Dimensions inside [] are in inches.

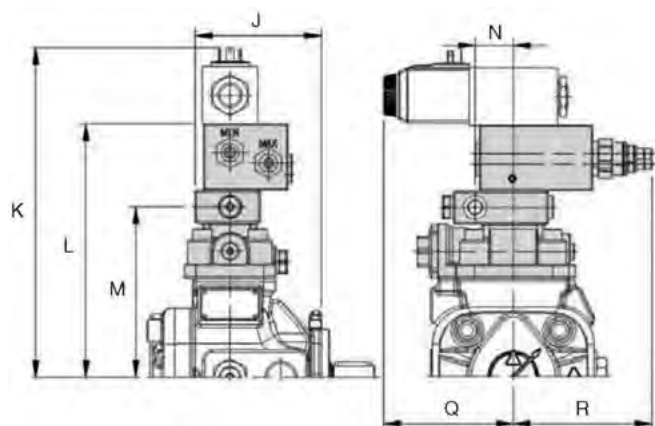

PRESSURE / FLOW-RATE CONTROLS

PCLS005 CONTROL

Hydraulic control with Load Sensing device and proportional pressure adjustment.

This control, with integrated proportional valve "W2" on the top of the compensator, adds to the adjustment of the pump flow-rate through the Load sensing system the possibility of setting the pump working pressure by means of an electrical signal.

Control performance depends on the type of throttle valve "Z", on the length / dimensions of the Load Sensing pilot pressure line, and on the proportional valve electronic control unit (**unit supplied only on request**).

Properties	
Pressure setting range	20 – 250 bar [290 – 3626 psi]
Differential pressure Δp	≥ 20 bar [≥ 290 psi]

Electrical properties	
Voltage	24 VDC $\pm 10\%$
Maximum current	590 mA
Power consumption	22 Watt
Nominal coil resistance at 50°C [122°F]	37.2 Ω $\pm 5\%$
Nominal coil resistance at 20°C [68°F]	26.2 Ω $\pm 5\%$
Maximum coil temperature at 20°C [68°F]	105°C [218°F]
Protection class	IP65
Recommended Dither frequency	160 – 200 Hz (*)
Linearity, Hysteresis, Repeatability	< 5% (*)
Connector	ISO/DIN 43650, Form A

(*): Depends on electronic control unit for the proportional valve
For available electronic control unit types, please contact Berarma Technical-Sales Service.

Control Devices	
"U2"	Load Sensing pressure compensator device
"SD"	Differential pressure Δp adjustment
"W2"	Proportional maximum pressure relief valve
"V1"	Load Sensing Block for additional controls
"Z"	Throttle (manual or electronic) (not supplied)

Ports	
"AB" – Air Bleed	1/4" Gas BSP ■
"MP" Pressure gauge	1/4" Gas BSP ■
"LS" Load Sensing port	1/4" Gas BSP □

The length between the throttle and the Load Sensing port must not exceed 5m [16ft].

■	Supplied port closed
□	Must be connected

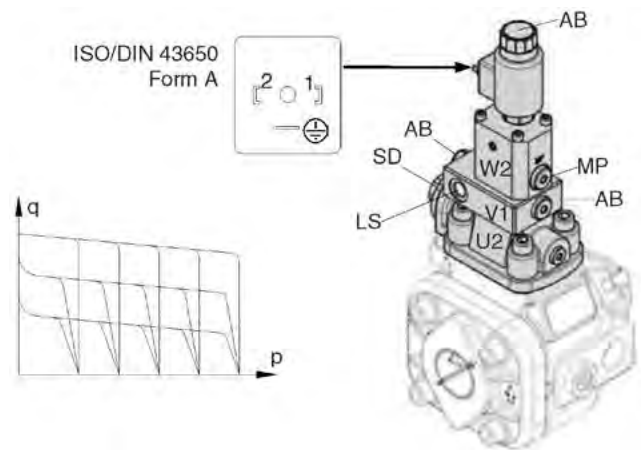
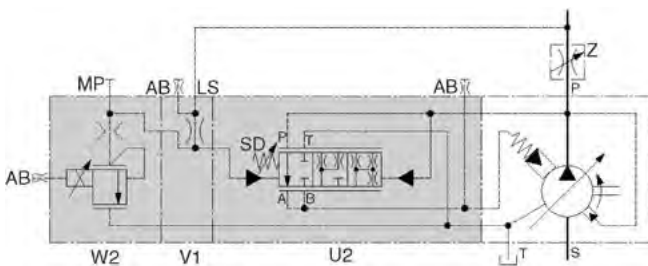

Designation	Dimensions	
	SIZE 05	SIZE 1
J	81 [3,189]	85 [3,346]
K	300 [11,811]	320 [12,598]
L	142 [5,591]	162 [6,378]
M	105 [4,134]	118 [4,646]
N	32 [1,260]	32 [1,260]

Indicative dimensions. For further information please contact Berarma Technical-Sales Service.
Dimensions inside [] are in inches.

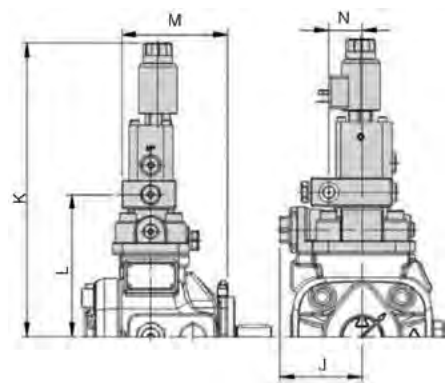

COMBINED PUMPS

On request, BERARMA pumps from the 01 PHV series can be set up for coupling:

- to pumps belonging to the same 01 PHV series;
- to pumps belonging to other BERARMA series (PLP, PVS, PSP, PSPK);
- to the main others types of pumps available on the fluid power market.

The 01 PHV series pumps set up for coupling are marked by the letter “A” in the ordering code. In these pumps, the shaft and the rear pump cover are set up for coupling to the various available coupling units.

- Remove the pump cover marked as (1) from the primary pump (cover will not be re-installed)
- remove the ring marked (2) from the primary pump (ring will not be re-installed)
- mount the coupling unit, paying attention to the seals (Note: primary pump drainage fluid will fill up the coupling bell-housing)
- mount the secondary pump

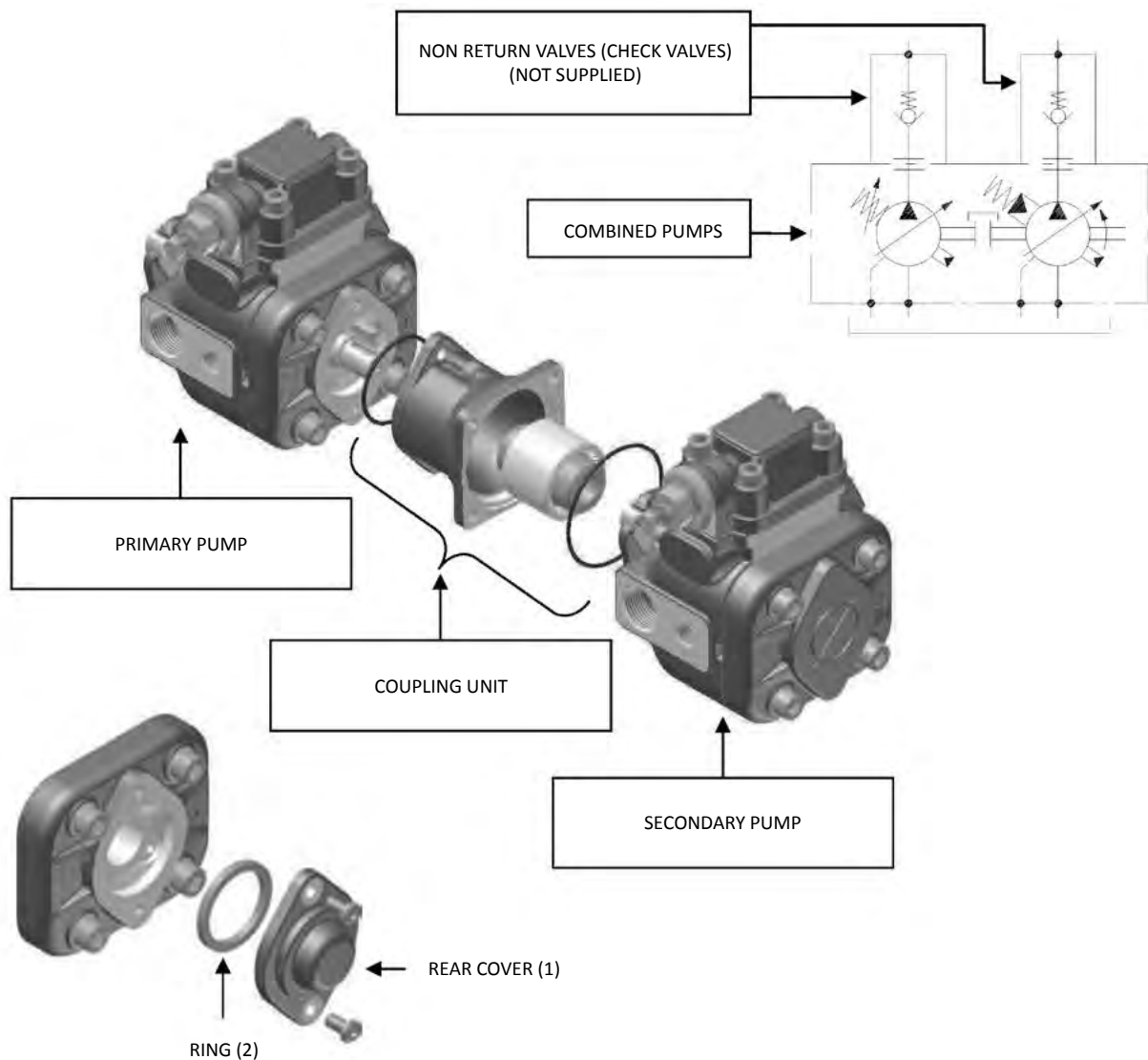

Combined pumps should be mounted in decreasing order of absorbed power, paying attention to the maximum acceptable torques (see diagram on the following page).

The ordering code for a combined pump should be specified according to coupling sequence (primary pump code + coupling unit code + secondary pump code).

COMBINED PUMPS

- The sum of individual torques of all pumps in the complete pump combination must not exceed the maximum permissible torque value applicable to the primary pump shaft (T_{max} see page 4).
- Secondary pump torque (or sum of torques for more than one secondary pump) must not exceed the coupling unit maximum thru drive torque (T_a , see table below).

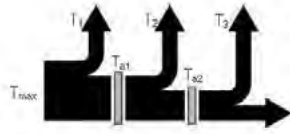

$$\begin{cases} T_1 + T_2 + T_3 < T_{max} \\ T_2 + T_3 < T_{a1} \\ T_3 < T_{a2} \end{cases}$$

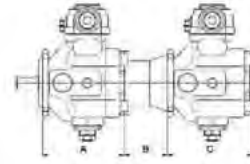

PRIMARY PUMP		SECONDARY PUMP		COUPLING UNIT		Maximum thru drive torque T_a
Pump type	A	Pump type	C	Code	B	
01 PHV 05 ... A	139 [5,472]	01 PLP 05 F	107 [4,213]	3000010200	73 [2,874]	55 Nm [487 lb in]
		01 PLP 05 FGR2	107 [4,213]	3000011200	72 [2,835]	
		01 PHV 05 F	145 [5,709]	3000010200	73 [2,874]	
		01 PHV 05 FGR2	145 [5,709]	3000011200	72 [2,835]	
		01 PHV 1 F	175 [6,890]	3000010100	75 [2,953]	
		02 PVS -PSP - PSPK - 1 F	159 [6,260]	3000010100	75 [2,953]	
		SAE "A"	(*)	3100000100	88.5 [3,484]	
		INGR. 1P - GEAR PUMP 1P	(*)	3000011000	64 [2,520]	
		INGR. 1 - GEAR PUMP 1	(*)	3000011100	64 [2,520]	
		INGR. 2 - GEAR PUMP 2	(*)	3000011200	72 [2,835]	
01 PLP 05 ... A	104 [4,094]	01 PHV 05 F	145 [5,709]	3000010200	73 [2,874]	
		01 PHV 05 FGR2	145 [5,709]	3000011200	72 [2,835]	
		01 PHV 1 F	175 [6,890]	3000010100	75 [2,953]	
PVS - PSP - PSPK Size 1	132 [5,197]	01 PHV 05 F	145 [5,709]	3000010200	73 [2,874]	
		01 PHV 05 FGR2	145 [5,709]	3000011200	72 [2,835]	
		01 PHV 1 F	175 [6,890]	3000010100	75 [2,953]	
01 PHV 1 ... A	173 [6,811]	01 PLP 05 F	107 [4,213]	3000020400	85 [3,346]	110 Nm [974 lb in]
		01 PLP 05 FGR2	107 [4,213]	3000022200	90 [3,543]	
		01 PHV 05 F	145 [5,709]	3000020400	85 [3,346]	
		01 PHV 05 FGR2	145 [5,709]	3000022200	90 [3,543]	
		01 PHV 1 F	175 [6,890]	3000020100	87 [3,425]	
		02 PVS -PSP - PSPK - 1 F	159 [6,260]	3000020100	87 [3,425]	
		02 PVS -PSP - PSPK - 2 F	220 [8,661]	3000020200	102 [4,016]	
		SAE "A"	(*)	3100000200	100.5 [3,957]	
		SAE "B"	(*)	3100000300	126.5 [4,980]	
		INGR. 1P - GEAR PUMP 1P	(*)	3000022000	90 [3,543]	
		INGR. 1 - GEAR PUMP 1	(*)	3000022100	90 [3,543]	
		INGR. 2 - GEAR PUMP 2	(*)	3000022200	90 [3,543]	
		INGR. 3 - GEAR PUMP 3	(*)	3000022300	91 [3,583]	
		02 PVS -PSP - PSPK - 3 F	245 [9,646]	3000020300	117 [4,606]	180 Nm [1593 lb in]
PVS - PSP - PSPK Size 2	173 [6,811]	01 PHV 05 F	145 [5,709]	3000020400	85 [3,346]	110 Nm [974 lb in]
		01 PHV 05 FGR2	145 [5,709]	3000022200	90 [3,543]	
		01 PHV 1 F	175 [6,890]	3000020100	87 [3,425]	
PVS - PSP - PSPK Size 3	198 [7,795]	01 PHV 05 F	145 [5,709]	3000020400	85 [3,346]	110 Nm [974 lb in]
		01 PHV 05 FGR2	145 [5,709]	3000022200	90 [3,543]	
		01 PHV 1 F	175 [6,890]	3000020100	87 [3,425]	

(*) For the secondary pump flange dimensions please see page 21.

To find out the secondary pump axial dimension please see the manufacturer's catalogue.

For other coupling unit types, please contact Berarma Technical-Sales Service.

Dimensions inside [] are in inches

SAE FLANGE DIMENSIONS FOR BERARMA COUPLING KIT

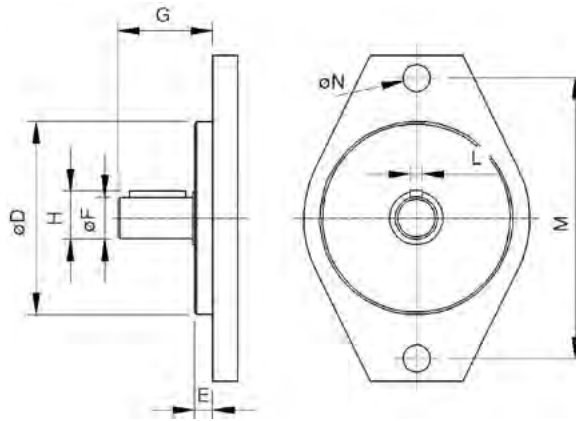

Secondary pump	Secondary pump with SAE 2-bolt mounting flange should conform to the dimensions below								
	$\varnothing D$	E	$\varnothing F$	G		H	L	M	$\varnothing N$
				min	max				
SAE "A"	$\varnothing 82.5$ [3.248]	7 [0.276]	$\varnothing 19.05$ [0.750]	32 [1.260]	59 [2.323]	21.1 [0.831]	4.8 [0.189]	106.4 [4.189]	11.1 [0.438]
SAE "B"	$\varnothing 101.6$ [4.000]	9.5 [0.374]	$\varnothing 22.2$ [0.874]	41 [1.614]	71 [2.795]	25.1 [0.988]	6.375 [0.251]	146 [5.748]	14.3 [0.563]
						25.5 [1.004]	4.8 [0.189]		

GEAR PUMP FLANGE DIMENSIONS FOR BERARMA COUPLING KIT

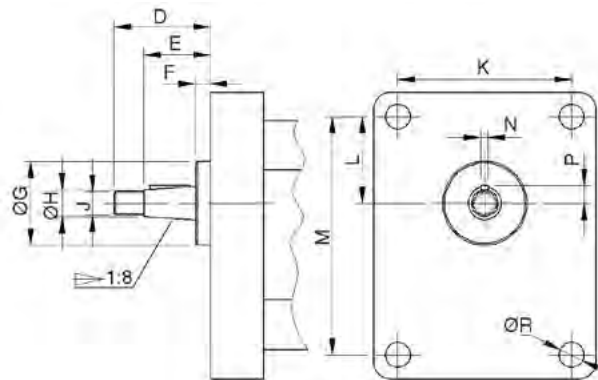

Secondary pump	Secondary gear pump should be conform to the dimensions below											
	D	E	F	$\varnothing G$	$\varnothing H$	J	K	L	M	N	P	$\varnothing R$
gear pump 1P	29 [1.142]	20 [0.787]	4 [0.157]	25.4 [1.000]	8 [0.315]	M7	52.4 [2.063]	26.2 [1.031]	71.9 [2.831]	2.4 [0.094]	5.3 [0.209]	7.5 [0.295]
gear pump 1	35 [1.378]	23.5 [0.925]	5.5 [0.217]	30 [1.181]	12 [0.472]	M10x1	56 [2.205]	24.5 [0.965]	73 [2.874]	3 [0.118]	7.9 [0.311]	6.5 [0.256]
gear pump 2	40 [1.575]	28 [1.102]	5 [0.197]	36.5 [1.437]	14.7 [0.579]	M12x1.5	71.5 [2.815]	32.5 [1.280]	96 [3.780]	4 (*) [0.157]	9.7 [0.382]	8.5 [0.335]
gear pump 3	47 [1.850]	33 [1.299]	5 [0.197]	50.8 [2.000]	19 [0.748]	M14x1.5	98.5 [3.878]	43 [1.693]	128 [5.039]	4 [0.157]	12.2 [0.480]	11 [0.433]

(*) It is also possible to couple size 2 gear pumps with an "M" dimension of 3.2 [0.126].

Dimensions inside [] are in inches

SETTINGS

Flow regulator unit

All BERARMA 01 PHV series pumps are equipped with a flow regulator unit. This allows the mechanical reduction of the pump displacement in relation to the nominal value.

Warning: If the flow regulator unit is set to less than 50% of the nominal displacement, the pump can only start on condition that the system and pump are completely filled with fluid.

Nominal size	Actual displacement	Reduced displacement by screw turn	Minimum achievable displacement
Size 05	17.9 cm ³ [1.092 in ³]	11.0 cm ³ [0.671 in ³]	3.3 cm ³ [0.201 in ³]
Size 1	34.5 cm ³ [2.105 in ³]	22.0 cm ³ [1.343 in ³]	8.3 cm ³ [0.506 in ³]

Indicative values influenced by manufacturing tolerances

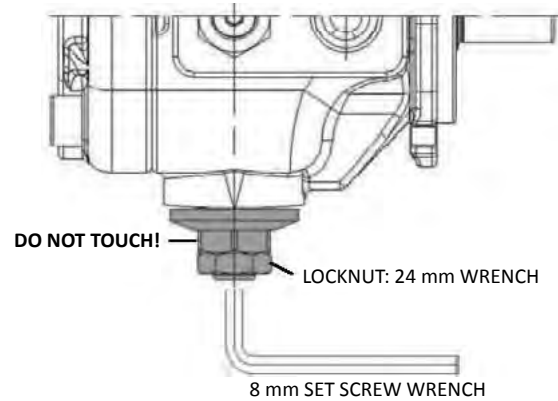

Standard pressure compensator device		
1	Pressure setting screw Clockwise rotation increases pressure setting	CH 13 mm HEX
2	Pressure setting locknut	CH 13 mm HEX
3	Slotted round locknut - Do not tamper	5 mm slot

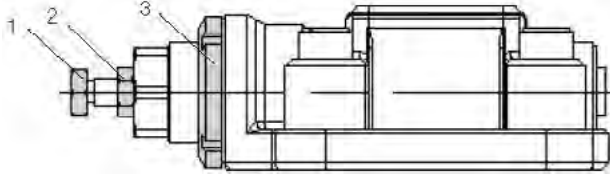

Pressure compensator device for additional controls Load Sensing pressure compensator device		
4	Controls PCS002, PCS003; PCS004, PCS005 Minimum pressure spring adjustment Do not tamper Controls PCLS001, PCLS002, PCLS003; PCLS004, PCLS005 Differential pressure Δp adjustment	CH 26 mm HEX
5	Slotted round locknut	5 mm slot
6	Maximum pressure relief valve	CH 5/32" HEX
7	Pressure setting screw Clockwise rotation increases pressure setting	CH 9/16" HEX
8	Pressure setting locknut	CH 9/16" HEX
	Do not tamper	CH 7/8" HEX

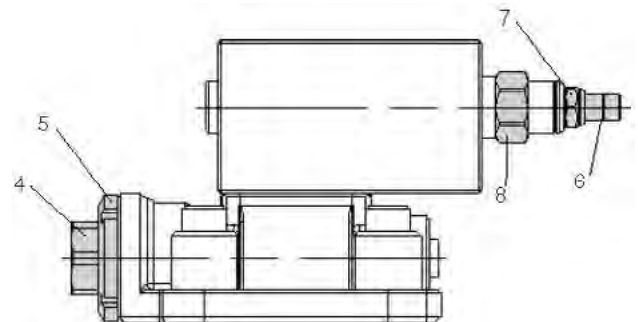

INSTRUCTIONS FOR INSTALLATION AND USE

SIZE 05 pumps from the 01 PHV series can be mounted in any position.

SIZE 1 pumps from the 01 PHV series must be mounted on a horizontal axis with the compensator device facing upward (see figure).

When the pump is installed over the reservoir fluid level, pay attention to the inlet pressure (see page 4).

Cleanliness is essential during assembly!

Motor-pump coupling must be made with a self-aligning flexible coupling with convex teeth and a polyamide cam. When assembling make sure that:

- **the distance between the two half-couplings strictly falls within the specified values (see page 24);**
- **the pump shaft and the motor shaft are accurately aligned: concentricity within 0.05 mm [0.002"], angular displacement within 0.2° (see drawing);**
- **strictly no radial or axial loads on the pump shaft.**

Other types of motor-pump coupling are not permitted.

The fluid tank must be suitably sized in order to exchange the thermal power generated by the various system components and to provide a low recycle rate (tank capacity approximately 4 times the flow rate per minute of the pump). In systems where the pump runs for a long time under zero flow setting conditions, the installation of a heat exchanger in the drain line is recommended (pay attention to the pressure on the drain port, see page 4).

Maximum operating temperature must not exceed 60°C [140°F] under any circumstances.

To ensure the maximum pump working life, the inlet fluid temperature must never be above 50°C [122°F].

Suction pipe. The suction pipe should be as short as possible, with a small number of bends and without internal section changes. The minimum section of the inlet pipe must be equal to the section of the thread of the pump inlet port. The pipe-end inside the tank should be cut at 45°, should have a minimum distance from the tank bottom of not less than 50 mm [2"], and there should always be a minimum height of suction of 100 mm [4"]. **The suction pipe should be completely airtight.**

Drain pipe. The drain pipe must always be independent from the other return lines, connected directly to the tank, and extended sufficiently inside the tank so as to be below the minimum fluid level to avoid generating foam and to prevent emptying when the pump is not running. Moreover, the drain pipe must also be at the highest possible position in relation to the pump in order to always prevent fluid emptying from the pump, and must be free of restrictions. **The drain pipe should be as far as possible from the suction pipe to prevent hot fluid being circulated.**

Pressure line. Ensure that the pressure line is strong enough. It is recommended that a non-return valve (check valve) is installed on the pump pressure line as well as an automatic air bleed valve, for trouble free operation.

Ensure that any valves, taps and gate valves on the suction and pressure pipes are fully opened and all protective caps removed. Fill the pump through the case drain port and replace the drain pipework. Check that the reservoir is full of fluid.

Ensure that the pump shaft can be rotated manually without any resistance.

Check that the motor rotation direction is the same as the pump rotation direction: right-hand rotation (clockwise) viewed from shaft end of the pump.

Start the motor (in jogging mode), allowing free circulation of fluid to the tank in order to facilitate priming.

The pump should prime within 5 seconds. If it does not, switch it off and investigate the cause. The pump should not run empty.

During INITIAL INSTALLATION, the pump must run under maximum flow conditions (P connected to T), with the fluid flowing directly into the tank, without pressure for several minutes. Care should be taken to eliminate all the air from the system during this process. Care should be taken to eliminate all the air from the system during this process. To facilitate this operation, there is an air bleed port on the pressure compensator device: unscrew the cap to bleed the air and then close the cap.

Subsequent start-ups under zero flow setting conditions are admissible only with pressure not exceeding 30 bar [435 psi], and with the system and pump completely filled with fluid.

If the volume adjustment unit is set to less than 50% of the nominal flow-rate, the pump can only start on condition that the system and the pump are completely filled with fluid.

INSTRUCTIONS FOR INSTALLATION AND USE

During the initial and subsequent starting operations, it is necessary that the pump (ambient) and fluid temperature do not differ by more than 20°C [68°F]. If this is the case, the pump should be switched on only for short intervals of approximately 1÷2 seconds (start/stop mode) without pressure, until the temperatures are balanced.

All Berarma products are covered by a **1 YEAR WARRANTY** for manufacturing or material defects effective from the shipment date, but in any case **NO LONGER THAN 18 MONTHS FROM THE PRODUCTION BATCH DATE**. The warranty is for the exclusive benefit of the original purchaser of the products.

For further information, please contact the Berarma Technical-Sales Service.

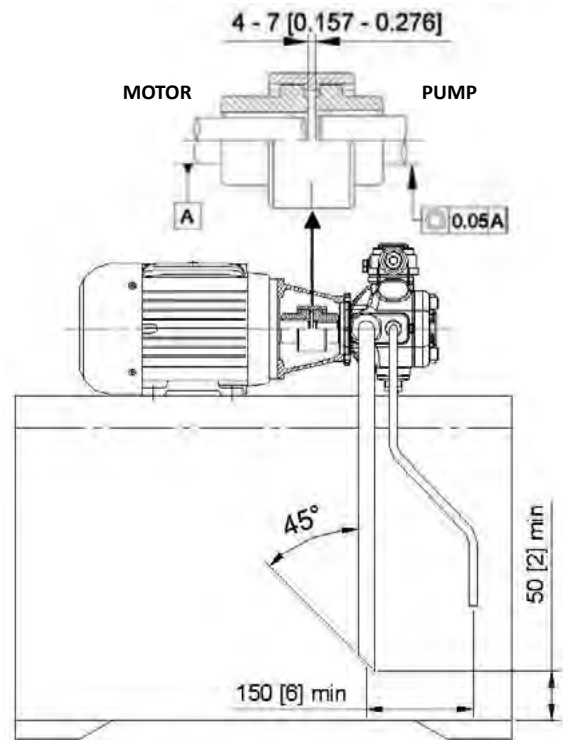
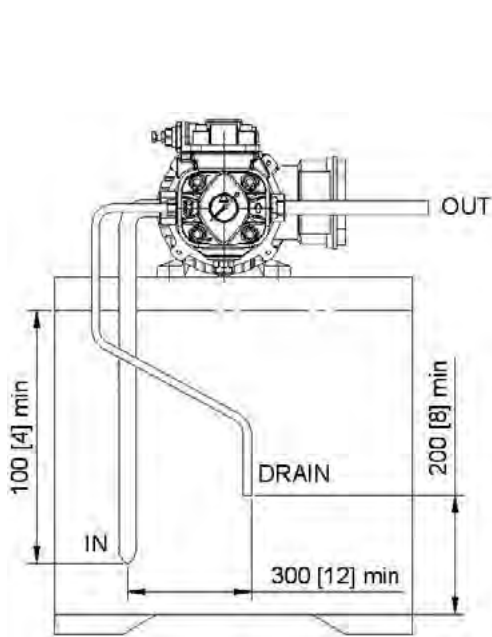

Dimensions inside [] are in inches

ASSEMBLY

E.G. 01-PHV-05-16-FHRM

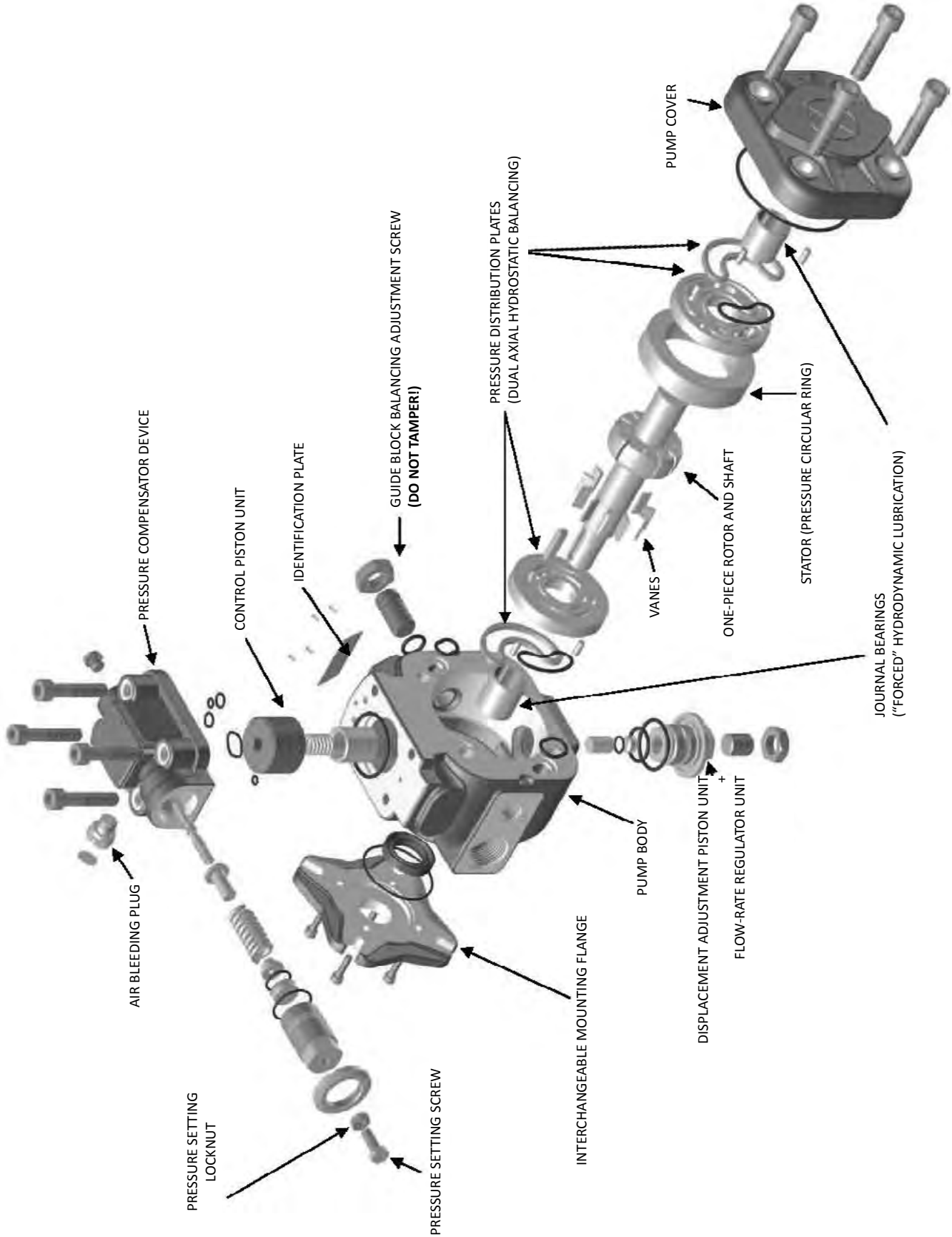

ASSEMBLY

