

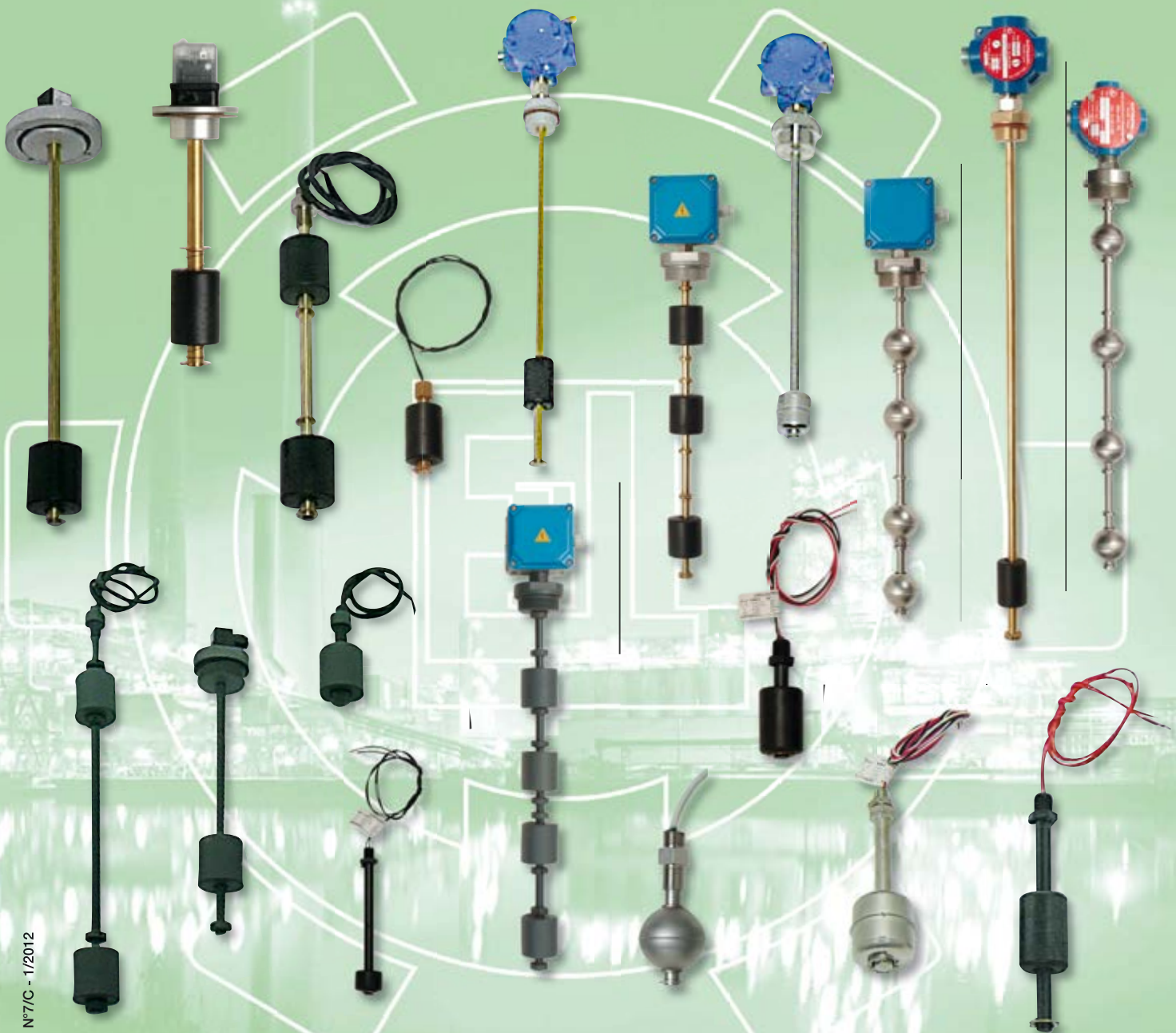

ELETTROTEC®

LIVELLOSTATI ELETTROMAGNETICI

Float level switches





ELETTROTEC®

S.R.L. MILANO

DATI TECNICI / TECHNICAL DATA

 RICH. OFFERTA
Inquiry OFFERTA
Offer LIVELLOSTATI ELETTROMAGNETICI
Electromagnetic level switches

DITTA/Company _____		TEL. _____		N./No _____	
VIA/Address _____		FAX _____		DATA/Date _____	
CAP/Zip Code _____ CITTÀ/Town _____		ATTNE/Attn _____			
<input type="checkbox"/> CLIENTE/Customer		VALIDITÀ OFFERTA/Offer validity		ESECUTORE/Executor	
<input type="checkbox"/> NUOVO CLIENTE/New Customer		COND. PAGAMENTO/Payment terms			
CARATTERISTICHE DEL FLUIDO/Fluid characteristics					
Tipo di fluido e PH/Type of fluid and PH					
Peso specifico/Specific weight				Kg/dm ³	
Viscosità/Viscosity				<input type="checkbox"/> cSt <input type="checkbox"/> mPa.s.	
Temperatura min-max/Min./max temperature				°C	
Temperatura esercizio/Operating temperature				°C	
Pressione esercizio/Operating pressure				bar	
Pressione min-max/Max pressure				bar	
Composizione del fluido/Composition of fluid					
Particelle in sospensione/Particles in suspension				micron	
DATI TECNICI ELETTRICI/Electrical specifications					
Lunghezza asta/Length		A...			mm
N. punti di intervento/No. of switching points		1	2	3	4
Distanza contatti mm./Contact distance in mm.		A...	B...	C...	D...
Tipo di contatto a riposo (senza fluido)/ Contact (dry condition)		<input type="checkbox"/> NA/NO <input type="checkbox"/> NC/NC	<input type="checkbox"/> NA/NO <input type="checkbox"/> NC/NC	<input type="checkbox"/> NA/NO <input type="checkbox"/> NC/NC	<input type="checkbox"/> NA/NO <input type="checkbox"/> NC/NC
Tipo di carico elettrico/Electric load		<input type="checkbox"/> Induttivo/ Inductive	<input type="checkbox"/> Resistivo/ Resistive	<input type="checkbox"/> Elettronico/ Electronic	<input type="checkbox"/> SPDT
Tipo di protezione/Protection		<input type="checkbox"/> IP 54	<input type="checkbox"/> IP 65	<input type="checkbox"/> IP 67	
Intensità di corrente/Current					A
Tensione di lavoro/Operating voltage		<input type="checkbox"/> V dc / cc			<input type="checkbox"/> V ca / ac
Potenza commutabile/Switching capacity					Watt
Distanza da campi magneti mm./Distance from magnetic fields in mm.		<input type="checkbox"/> 50	<input type="checkbox"/> 100	<input type="checkbox"/> 200	<input type="checkbox"/> 500
					<input type="checkbox"/> > 500
TIPI MATERIALI DEI COMPONENTI/Materials					
Tipo materiale flangia/Flange		<input type="checkbox"/> Alluminio Aluminium	<input type="checkbox"/> Inox 304 304 stainless steel	<input type="checkbox"/> PVC	<input type="checkbox"/> Termoplastica Thermoplastic
Tipo materiale asta/Stem		<input type="checkbox"/> Ottone Brass	<input type="checkbox"/> Inox 316 316 stainless steel	<input type="checkbox"/> PVC	
Tipo materiale galleggiante/Float		<input type="checkbox"/> NBR	<input type="checkbox"/> Inox 316 316 stainless steel	<input type="checkbox"/> PVC	
Cavi di collegamento interni/Inside connecting cables		<input type="checkbox"/> PVC	<input type="checkbox"/> Silicone Silicone		
Dimensione attacco filettato/Thread connection		<input type="checkbox"/> G 1/8	<input type="checkbox"/> G 1/4	<input type="checkbox"/> G 3/8	<input type="checkbox"/> G 1/2
				<input type="checkbox"/> G 3/4	<input type="checkbox"/> G 1
					<input type="checkbox"/> G 1 1/4
					<input type="checkbox"/> G 1 1/2
					<input type="checkbox"/> G 2
NOTE					
TIPO PRODOTTO/Model		CODICE/Code		N. PEZZI/Pcs	
		PREZZO Cad./ Unit Price		SCONTO/Disc.	
				CONSEGNA/ Delivery	

Elettrotec firma il terzo millennio

Elettrotec designs the third millennium

Elettrotec studia e produce apparecchi di controllo per fluidi standard e speciali su misura per il cliente: **pressostati, vuotostati, termostati, livellostati, flussimetri, flussostati, sonde di livello continue, indicatori programmabili.**

Prodotti certificati RINA, Lloyd's Register, Germanischer Lloyd, GOST, IMQ, ATEX, UL.
Sistema qualità UNI EN ISO 9001:2008.

Elettrotec designs and manufactures a wide range of control devices for fluids both as standard and tailor-made executions to meet customers' particular requirements.

Products certified by: RINA, Lloyd's Register, Germanischer Lloyd, GOST, IMQ, ATEX, UL.

Quality System Management ISO 9001:2008.



PRESENTAZIONE DELLA SOCIETÀ

Company profile

Fondata nel 1977 Elettrotec ha iniziato la sua attività con la progettazione e produzione di pressostati miniaturizzati regolabili, indicatori di livello elettromagnetici, flussimetri e flussostati visivi ed elettrici regolabili.

Il rapido ed incoraggiante inserimento nel mercato ha indotto la Società a muoversi verso investimenti mirati e ad aggiornare costantemente la gamma prodotti, in linea con l'evolversi della tecnologia e sempre nella precisa visione di soddisfare le necessità dei propri clienti. Durante i suoi 35 anni di attività, caratterizzati da grandi mutamenti e crescente competitività, Elettrotec ha saputo migliorare e ampliare la propria offerta con nuove serie di livellostati, flussostati, pressostati, vuotostati e termostati cogliendo le aspettative dei clienti e del mercato in generale sia italiano che estero.

Questo processo di evoluzione e l'attenzione dedicata ai rapidi mutamenti richiesti dal mercato sono tuttora parte integrante della politica aziendale. Infatti, oltre alle molteplici soluzioni specifiche e personalizzate sviluppatesi nel tempo, al core business consolidato dell'azienda, si sono aggiunte anche nuove linee espressamente dedicate al settore dell'elettronica e dell'automazione di fabbrica. Una sfida questa intrapresa per poter ampliare l'offerta Elettrotec anche a tutte quelle applicazioni che oggi richiedono un monitoraggio più preciso dei processi. Inoltre, a completamento della produzione, è d'obbligo citare anche una vasta gamma di accessori, quali cappucci di protezione e connettori, tra i quali spicca la nuova serie di connettori DIN con involucro trasparente e LED bicolore rosso/verde, ideata per essere impiegata su tutta la gamma di prodotti Elettrotec e non solo.

I grandi investimenti e l'impegno profuso hanno comunque portato a ottimi risultati, rendendo la Società una vera protagonista nel campo della strumentazione. Elettrotec vanta oggi una presenza altamente qualificata in importanti settori, quali: oleodinamica, pneumatica, industria meccanica, farmaceutica, elettromedicale, cosmetica, alimentare, tessile e ospedaliera, trasporto ferroviario, macchine agricole, automazione, impianti di lubrificazione, ascensori, sistemi antincendio, macchine movimento terra e scambiatori di calore.

La Società, certificata UNI EN ISO 9001: 2008, è fortemente caratterizzata dal lavoro di team, dove tutte le componenti aziendali – dal Marketing alla Spedizione materiali – collaborano a stretto contatto. Questo, unitamente alla consapevolezza di dover competere a livello mondiale, forma il cardine di quello che la direzione definisce un sistema organizzativo in continuo sviluppo, in perfetta sintonia con quelle che sono le esigenze di un mercato estremamente dinamico e in costante evoluzione.

PRODUZIONE: APPARECCHI DI CONTROLLO PER FLUIDI

Gamma prodotti: pressostati, vuotostati, termostati, livellostati, flussimetri e flussostati, sensori di livello, indicatori elettronici programmabili, trasmettitori di pressione e pressostati elettronici, flussimetri ad area variabile, cappucci di protezione, connettori.

Sede Operativa e Centro Assistenza Clienti:
Milano, Via Jean Jaurés, 12.

Established in 1977 Elettrotec began first with the design and manufacturing of adjustable miniature pressure switches, electromagnetic float level switches and electric flow indicators and switches with or without visual indication.

The fast and encouraging penetration in the market led the Company to direct its efforts towards investment aimed at steadily updating the products in offer, keeping up with the progress in technology and always answering to any customer's requirements. With 35 years of experience, years of radical changes and increasing competitiveness, Elettrotec has been able to improve and enlarge the product range with new series of level switches, flow indicators, pressure, vacuum and temperature switches, coming up to the expectations of the customers and the market in general, both in Italy and abroad.

Constant development and the attention paid to the fast changes required by the market are still an integral part of the Company policy. In fact, besides specific and custom-made solutions developed in years of experience, the established Elettrotec core business has been also added with new product lines for the electronic industrial automation. A challenge that the Company has to embark on, in order to expand its offer in all those applications requiring nowadays most accurate process monitoring. Moreover, to give a comprehensive idea of the Elettrotec production, it has to be also mentioned a wide range of excellent accessories, such as protection caps and connectors, among which stands out in particular the new series of DIN connectors with transparent housing and red/green LED, designed to suit and fit not only the Elettrotec product range.

The huge investments and the great commitment yielded more than satisfactory results, letting Elettrotec become a primary player in the field of instrumentation. Thanks to its high standard quality products, the Company is now very well-established in important sectors, such as: hydraulics, pneumatics, mechanical, pharmaceutical, medical, cosmetic, food, textile and healthcare industry, railway transportation, agricultural machinery, automation, lubrication plants, lifting systems, fire prevention, heat exchangers and earthwork machinery.

Elettrotec, certified according to UNI EN ISO 9001:2008, is characterized by team work. All the departments, from Marketing to the Shipping one, work closely together also wellaware to have to compete worldwide. This is the cornerstone of the Elettrotec organization, a structure that, according to the Management, is constantly growing and perfectly tuned with the requirements of an extremely dynamic market in a non-stop and progressive evolution.

PRODUZIONE: CONTROL DEVICES FOR FLUIDS

Product range: pressure switches, vacuum switches, temperature switches, float level switches, flow indicators and switches, level sensors, programmable digital indicators, electronic pressure transmitters and switches, variable area flow meters, protection caps, connectors.

Business Premises and Customer Service:
Milan, Via Jean Jaurés, 12.

LIVELLOSTATI ELETTROTEC

Float level switches

I livellostatii ELETTROTEC sono stati studiati per soddisfare le più svariate esigenze applicative nel campo del controllo del livello di liquidi. L'ampia gamma offerta sia di modelli standard, con uno o due galleggianti, che di esecuzioni customizzate assicura massima flessibilità nella scelta e garantisce la possibilità di trovare sempre la soluzione più adatta alle proprie necessità, anche le più specifiche. Le esecuzioni speciali sono disponibili sia con un singolo punto di intervento/galleggiante che fino ad un massimo di quattro galleggianti (a seconda dei modelli) e con lunghezze fino a 2500 mm. I materiali impiegati per le parti a contatto con il fluido includono alluminio, materiale termoplastico, PVC, NBR, Nylon, Hostaform, ottone e acciaio inox.

Sono disponibili modelli con attacco a flangia e attacco filettato GAS o metrico, cavi di collegamento, connettore DIN o scatola di collegamento. Su richiesta possono essere fornite esecuzioni con cavi di collegamento di lunghezza speciale, cavi al silicone per applicazioni con temperature elevate, esecuzioni antideflagranti (EExd) e a sicurezza intrinseca (EExia) secondo Direttiva ATEX 94/9/CE

I livellostatii ELETTROTEC sono particolarmente adatti per l'impiego in applicazioni oleodinamiche, impianti di lubrificazione, veicoli industriali, gruppi elettrogeni, stoccaggio fluidi, industria alimentare e farmaceutica, trattamento acque, macchine idropultrici.

Per applicazioni specifiche in campo navale sono disponibili modelli certificati R.I.N.A., Lloyd's Register e Germanischer Lloyd.

FUNZIONAMENTO

Il principio di funzionamento dei livellostatii ELETTROTEC è molto semplice e diretto. Un'ampolla reed alloggiata nell'asta viene sollecitata da un campo magnetico generato da un magnete contenuto nel galleggiante che, scivolando lungo l'asta seguendo il livello del liquido, fa commutare il contatto elettrico.

I livellostatii ELETTROTEC sono studiati per essere montati verticalmente dall'alto del serbatoio ma nella gamma sono inclusi anche modelli ad angolo adatti per montaggio laterale. Tutti i modelli lavorano correttamente fino ad una inclinazione massima di 15°.

Alcuni modelli con uno o due punti di intervento sono dotati di contatto reversibile e possono pertanto lavorare sia con contatto Normalmente Chiuso (NC) che con contatto Normalmente Aperto (NA). Basta semplicemente smontare e girare il galleggiante per passare da un tipo contatto all'altro. La maggior parte dei modelli non è però dotata di contatto reversibile, pertanto, al momento dell'ordine, è necessario indicare espressamente il tipo di contatto richiesto: NA o NC.

ELETTROTEC float level switches are designed to meet the most complete range of application requirements in liquid level monitoring. The wide offer both of standard level switches with one or two floats and custom length executions assures greatest choice flexibility and gives the possibility to select the best level control solution for any specific application. Custom length units may be configured with a single station, or as many as four (depending on series), in lengths up to 2500 mm.

Mounting, float and stem materials include aluminium, thermoplastic, PVC, NBR, Nylon, Hostaform, brass and stainless steel.

Different mounting styles are available such as flanges, GAS and metric thread mounting plugs. A variety of wire terminations, custom lead lengths, Silicone cable jacket for high temperature applications, housing and connectors are also available. Explosion-proof executions (EExd) and models intrinsically safe approved (EExia) according to Directive ATEX 94/9/EC can be supplied on request.

ELETTROTEC level switches are particularly suitable for hydraulics, lubrication plants, pharmaceuticals, water treatment, industrial vehicles, generating sets, fluid stocking, food and beverage processing, cleaning machines and equipment.

Executions specifically approved R.I.N.A., Lloyd's Register, Germanischer Lloyd for marine and offshore applications are also available.

OPERATING PRINCIPLE

ELETTROTEC level switches operate on a direct, simple principle. The hermetically sealed reed switch housed inside the stem is actuated by a magnetic field created by a magnet equipped float. As the float rises and lowers with liquid level, the magnetic field passing the switch in the stem causes the switch to either open or close.

ELETTROTEC level switches are generally mounted from tank top, but some models have been adapted for side mounting. Switches will operate normally with up to a 15° tilt from vertical.

Some single/double point switches operate in either a Normally Open (NO) or Normally Closed (NC) mode. Selecting the mode is as easy as removing the retaining clip and reversing the float on the stem. However, the most part is non-reversible and must be clearly ordered as NO or NC.

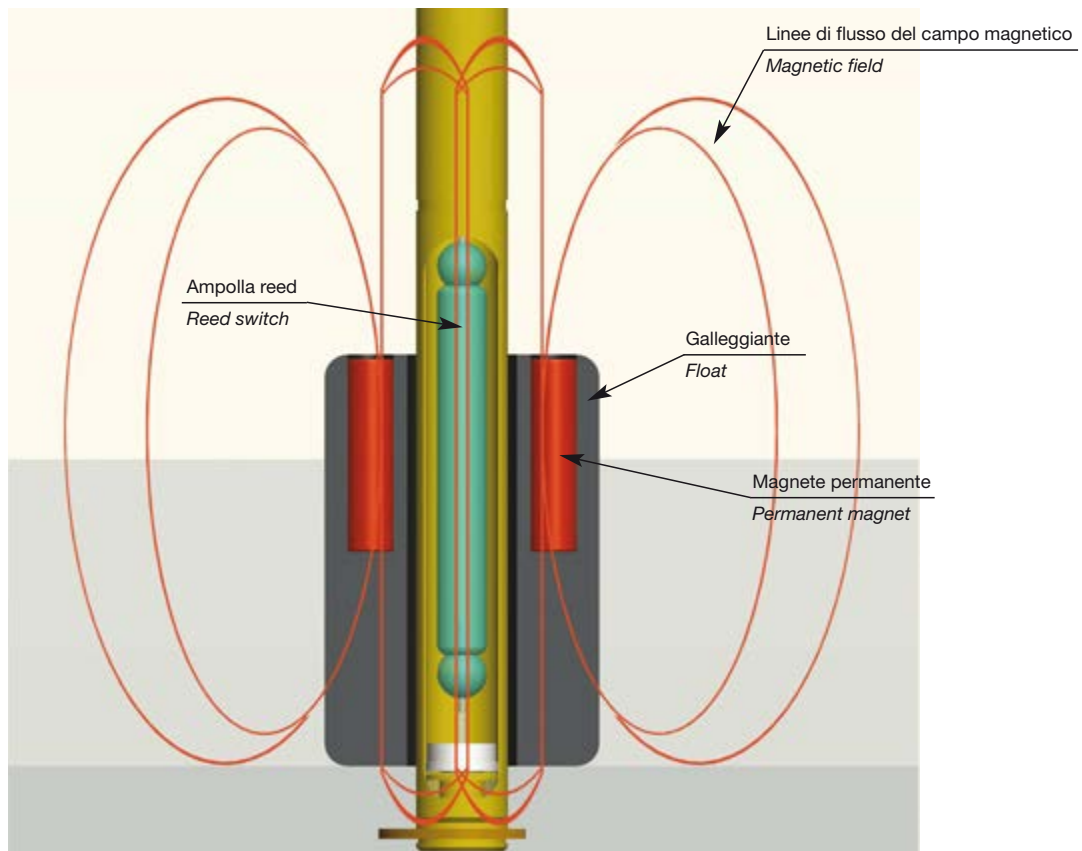

DATI TECNICI GENERALI

Max viscosità fluido: 150 cSt
Pressione massima: 10 bar
Peso specifico: $\geq 0,7$
Connessione elettrica: PG09 – DIN43650
Protezione elettrica: IP65 – DIN40050
Temperatura di lavoro: $-10^{\circ}\text{C} \dots +80^{\circ}\text{C}$
Temperatura max con guarnizioni FKM e cavi Silicone: $+130^{\circ}\text{C}$

DATI ELETTRICI

Le ampole reed utilizzate nei livellostati ELETTRITEC sono ermeticamente sigillate, ad attuazione magnetica e con una affidabilità di milioni di cicli.
Il tipo di contatto a riposo è Normalmente Chiuso/Normalmente Aperto (SPST) o in scambio (SPDT). La portata dei contatti varia secondo il tipo di ampola reed adottata. Per i dati elettrici fare riferimento alla tabella sotto riportata.

GENERAL SPECIFICATIONS

Max. fluid viscosity: 150 cSt
Max. pressure: 10 bar
Fluid specific gravity: $\geq 0,7$
Electrical connection: PG09 – DIN43650
Electrical protection: IP65 – DIN40050
Operating temperature: $-10^{\circ}\text{C} \dots +80^{\circ}\text{C}$
Max temperature with FKM gasket and Silicone cable: $+130^{\circ}\text{C}$

ELECTRICAL DATA

Standard reed switches in ELETTRITEC level switch units are hermetically-sealed, magnetically actuated, designed for reliability to millions of cycles.
Switches are Normally Closed/Normally Open (SPST) or SPDT. Each ELETTRITEC level switch varies in rating depending on the type of reed switch used, see the chart below for electrical ratings.

Tensione Max Max Voltage	Potenza Commutabile Rating Power	Corrente Max Max Current	Capacità Contatti Capacitance	Resistenza Isolamento Insulation Resistance	Contatto (a riposo) Switch Type (dry)
220V – 50Hz	60 W 60 VA	0.8A	0.6pF	10^{10} Ohm	NC
220V – 50Hz	60 W 60 VA	0.8A	0.6pF	10^{10} Ohm	NA/NO Modelli reversibili Reversible float
220V – 50Hz	30 W	0.5A	2pF	10^9 Ohm	NA/NO Modelli non reversibili Non-reversible float
220V – 50Hz	30 W	0.5A	2pF	10^9 Ohm	SPDT

ATTENZIONE: la combinazione tra la tensione e la corrente di commutazione non deve mai superare la potenza commutabile indicata in tabella.

I valori elettrici relativi alla portata dei contatti si riferiscono a **carichi resistivi**. Per applicazioni che implicano carichi induttivi o capacitivi è richiesto l'impiego di addizionali circuiti protettivi. Per assicurare lunga durata e ripetibilità dei contatti fare riferimento alle informazioni tecniche di pagina 6 e 7.

WARNING: any combination of the switching voltage and current must not exceed the given rated power.

The switch contact ratings, as listed in the switch data chart, are based on use with **resistive type load**. For applications requiring the control of an inductive or capacitance load, additional interface circuitry may be required. To ensure long life and repeatability, see the contact protection information on pages 6 and 7.

MODEL / MODEL	PUNTI DI INTERVENTO ACTUATION POINTS	TIPO DI CONTATTO CONTACT TYPE
LM1...	1 punto di intervento / 1 actuation point	NC
LM1...NA	1 punto di intervento / 1 actuation point	NA / NO
LM2...	1 punto di intervento / 1 actuation point	SPDT
LMM1...	2 punti di intervento - 1 galleggiante 2 actuation points - 1 float	Min. NC Max. NA / NO
LMM1...	2 punti di intervento - 2 galleggianti 2 actuation points - 2 floats	Min. NC Max. NC
LM3...	3 punti di intervento - 3 galleggianti 3 actuation points - 3 floats	NC/NC/NC
LM4...	4 punti di intervento - 4 galleggianti 4 actuation points - 4 floats	NC/NC/NC/NC

A richiesta, i modelli LMM1..., LM3..., LM4... sono disponibili con altre combinazioni di contatti.
On request, LMM1... – LM3... – LM4... models can be supplied with different switch operations.

INFORMAZIONI TECNICHE

Technical information

CIRCUITI PROTETTIVI PER CONTATTI REED

I valori relativi alla portata della corrente e della tensione, indicati nei dati tecnici si riferiscono a carichi resistivi. Spesso, tuttavia, si devono controllare carichi induttivi o capacitativi, oppure si devono azionare lampade.

Per situazioni di questo tipo è necessaria qualche considerazione circa l'opportunità di proteggere i contatti reed dai picchi di tensione o di corrente.

1) Carichi induttivi

In presenza di circuiti alimentati con corrente continua, la protezione del contatto è relativamente facile. Si deve collegare in parallelo al carico un diodo semiconduttore come indicato nella fig. 1. Le polarità devono essere collegate in modo che il diodo si blocchi con il normale voltaggio di esercizio e sempre in corto circuito nel caso di inversione delle polarità.

Quando si commutano dei carichi induttivi, alimentati con corrente alternata, non si può utilizzare un diodo, bisogna usare un dispositivo di soppressione dell'arco RC. Di solito si tratta di un collegamento RC parallelo al commutatore e quindi in serie con il carico, come da fig. 2. La dimensione del soppressore di arco può essere determinata dal monogramma di fig. 3.

2) Carichi capacitivi e lampade

Al contrario di quanto avviene con i carichi induttivi, con i carichi capacitivi e con lampada si hanno elevate scariche di corrente che possono provocare guasti immediati, e persino la saldatura dei contatti. Quando si commutano dei condensatori carichi o dei condensatori di linea, si ha un'immediata scarica la cui intensità dipende dalla portata e dalla lunghezza dei collegamenti. La corrente di scarica o di picco è limitata da un resistore in serie con il condensatore, come è indicato nella fig. 4. La dimensione del resistore sarà determinata in base alle possibilità esistenti nell'ambito di un particolare circuito. In ogni caso, dovrebbe essere il più grande possibile per limitare lo scarico di corrente entro limiti accettabili. Quando detto vale anche per il carico con condensatori.

Per quanto riguarda i circuiti con condensatori ad elevata scarica di corrente, andrebbero usati i circuiti come da fig. 5, con R_1 o R_2 .

Le lampade al tungsteno aumentano da 5 a 15 volte la corrente nominale durante i primi 10 millisecondi di funzionamento. Queste elevate scariche di corrente possono essere limitate entro valori accettabili con l'aggiunta di resistenze collegate in serie per limitare la corrente. Un'altra possibilità consiste nel collegare una resistenza in parallelo con il commutatore in modo che i filamenti delle lampade vengano pre-riscaldati proprio sino al punto in cui non diventano incandescenti quando vengono accese. Entrambi i metodi comportano una perdita di corrente.

PROTECTIVE CIRCUITS FOR REED CONTACTS

The values for current, voltage, and capacity as given in the technical data refer to pure resistive loads. However, inductive or capacity loads are often to be checked or lamps are to be switched.

In this case it is necessary to protect the reed contacts against peaks in voltage or current.

1) Inductive loads

The contact protection is relatively easy with direct current. A semiconductor diode is to be connected in parallel to the load, as indicated in picture 1.

Polarities must be connected in a way the diode would simply jam under normal operating voltage and always short-circuit the opposing voltage that occurs with the opening of the switch.

When inductive loads, fed with alternating current, are switched, it is not to be used a diode but an arc-suppression unit.

An RC link connected in parallel to the switch, and therefore in series with the load, is usually applied, see picture 2. The arc-suppression size can be taken from a chart, as from picture 3.

2) Capacity loads and lamp switching-on

Contrary to inductive loads, high current inrushes occur with capacitive loads or switched-on lamps, and that may lead to early switch failure or even to welding of contacts.

When charged capacitors or cable capacitors are switched, a sudden discharge occurs, the intensity of which depends on the capacity and length of the connecting cables. A resistor in series with the capacitor limits the current peaks or discharges, as shown in picture 4.

The size of the resistor depends on the different possibilities offered by a particular circuit. In any case the resistor should be the biggest possible to limit the current discharge within acceptable values. The same applies also to charging of capacitors.

Protection against high current discharges from capacitors should be provided by means of the circuit R_1 or R_2 or both, as shown in picture 5.

Tungsten lamps increase from 5 to 15 times the rated current during their first ten milliseconds of working. These high current inrushes can be limited to an acceptable value connecting in series current-limiting resistances or connecting in parallel to the switch a resistance, so that the lamp filaments would be preheated just to the point they would not incandescent when turned on. Both protecting solutions imply a loss of power.

Monogramma per determinare la soppressione dell'arco di contatto per carichi induttivi.

Graph for determining the contact arc suppression for inductive loads.

Esempio 1: $I = 0,1 A$
 $V_L = 220 V$
 $C = 0,001 \mu F$
 $R = 340 \Omega$

Example 1: $I = 0,1 A$
 $V_L = 220 V$
 $C = 0,001 \mu F$
 $R = 340 \Omega$

Esempio 2
 Quando la scarica di corrente è critica, la resistenza dovrebbe essere determinata con il monogramma più basso, ad esempio: scarica di corrente 0,5 A
 $R_{min} = 400 \Omega$

Example 2:
 When the inrush current is critical, the resistance should be determined with the lower graph, for example inrush current 0.5 A
 $R_{min} = 400 \Omega$

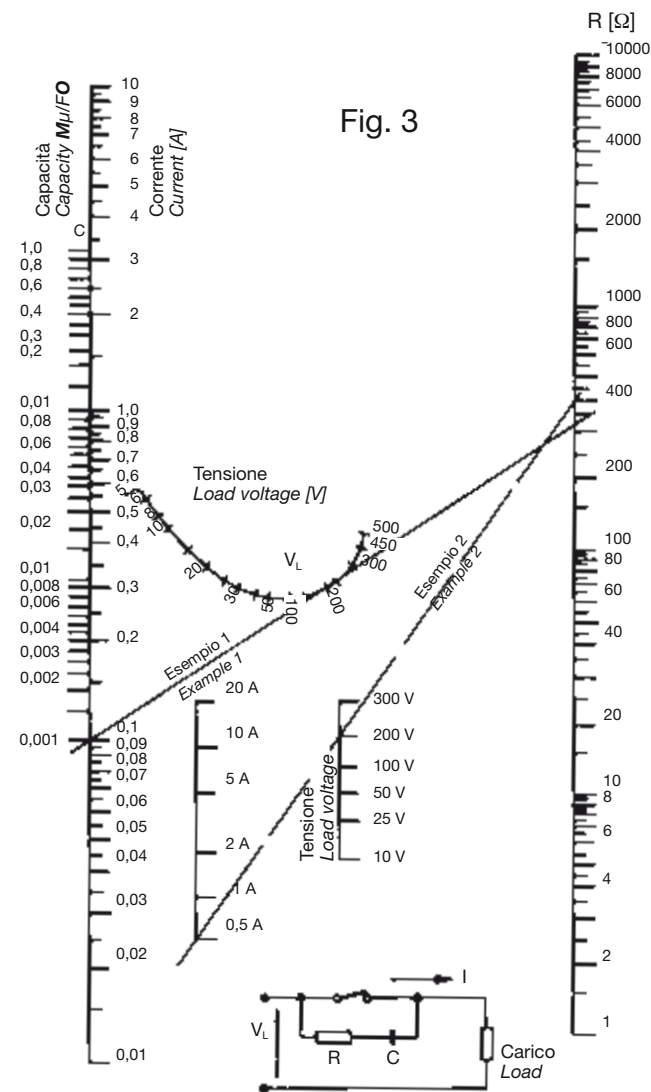

Fig. 3

Circuiti protettivi per contatti Reed Protective circuits for Reed contacts

Carichi induttivi Inductive loads

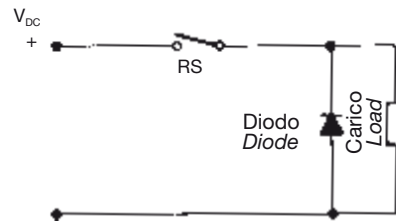

Fig. 1

Protezione con corrente continua per carichi induttivi.
 Direct current protection with semiconductor diode for inductive loads.

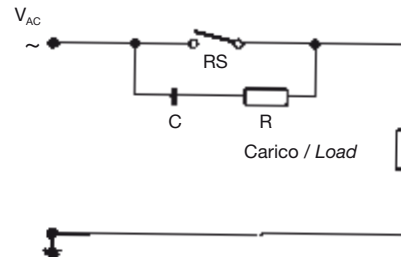

Fig. 2

Protezione con corrente alternata con collegamento RC per carico induttivo.
 Alternating current protection with RC link for inductive load.

Carichi capacitivi e lampade Capacitive Loads and Lamps

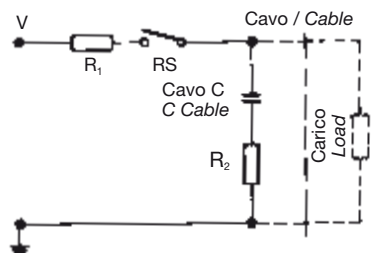

Fig. 4

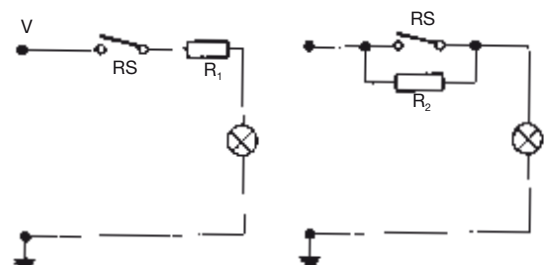

Fig. 5

Circuito con lampada, resistenza in parallelo o in serie con il commutatore.
 Lamp load resistance in parallel or in series with switch.

Filtro dimensionato con il collegamento RC Arc suppressor with RC link

LIVELLOSTATI ELETTROMAGNETICI

Float level switches

LEM5

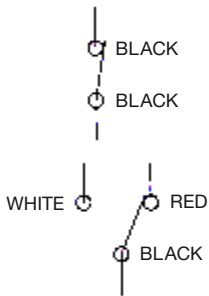
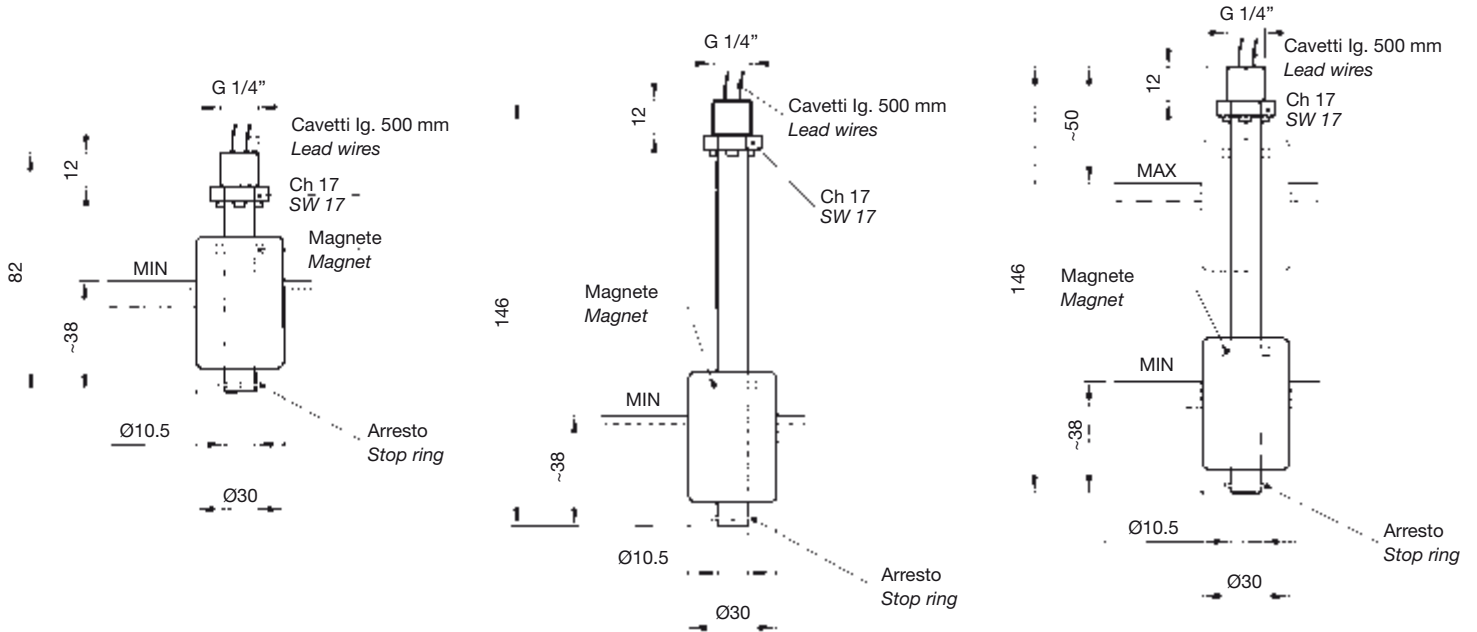

LEM5CN
NC CONTACT

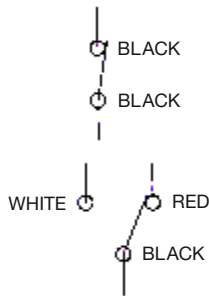

LEM5LN
NC CONTACT

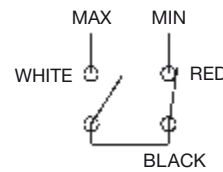

LEM5M
MIN - MAX CONTACTS

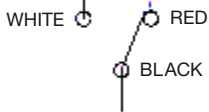

LEM5CNSC
SPDT CONTACT

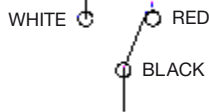

LEM5LNSC
SPDT CONTACT

IMPIEGO

Sono stati studiati per controllare il minimo o il massimo livello di olio, acqua, solventi contenuti in un serbatoio e per inviare a distanza un segnale elettrico. A seconda dei tipi, devono essere montati verticalmente sul coperchio del serbatoio in modo che il galleggiante disti almeno 50 mm dalle pareti metalliche.

USE

This series of electromagnetic level switches has been designed to check the minimum or maximum level of oil, water, solvents in a tank and send an electric signal to a remote board in case the fluid goes over or under the set levels. These level switches should be fixed vertically on the cover of the tank, with the float at least 50 mm far from metal walls.

DATI TECNICI

Potenza commutabile in CC	60 W
Potenza commutabile in CA	60 VA
Intensità di corrente	0.8 A (resistivi)
Tensione max. di lavoro	220 V - 50 Hz
Tensione di breakdown	300 V
Capacità dei contatti aperti	0,6 pF
Resistenza d'isolamento	10 ¹⁰ Ohm

CON CONTATTI SPDT (SC)

Potenza commutabile	30 W
Corrente commutabile	0,5 A (resistivi)
Resistenza d'isolamento	10 ⁹ Ohm min.
Capacità dei contatti	2 pF
Campo di temperatura	-10 +80°C
Peso specifico fluido	≥ 0,7
Pressione massima	5 Bar
Viscosità del fluido	max 150 cSt
Materiali	Nylon nero monocolpo galleggiante in resina espansa NBR

SPECIFICATIONS

Switching capacity in DC	60 W
Switching capacity in AC	60 VA
Current	0.8 A (resistive)
Voltage	220 V - 50 Hz
Breakdown voltage	300 V
Capacitance	0,6 pF
Insulation resistance	10 ¹⁰ Ohm

WITH SPDT CONTACTS (SC)

Switching capacity	30 W
Current	0.5 A (resistive)
Insulation resistance	10 ⁹ Ohm min.
Capacitance	2 pF
Temperature range	-10 +80°C
Fluid specific gravity	≥ 0,7
Maximum pressure	5 Bar
Fluid viscosity	max 150 cSt
Material	compact body in black Nylon; NBR float.

PER CARICHI INDUTTIVI IMPIEGARE CIRCUITO DI PROTEZIONE.

WITH INDUCTIVE LOADS A PROTECTION CIRCUIT IS TO BE USED.

LIVELLOSTATI ELETTROMAGNETICI

Float level switches

LEM6

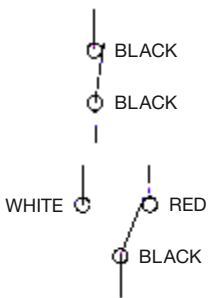
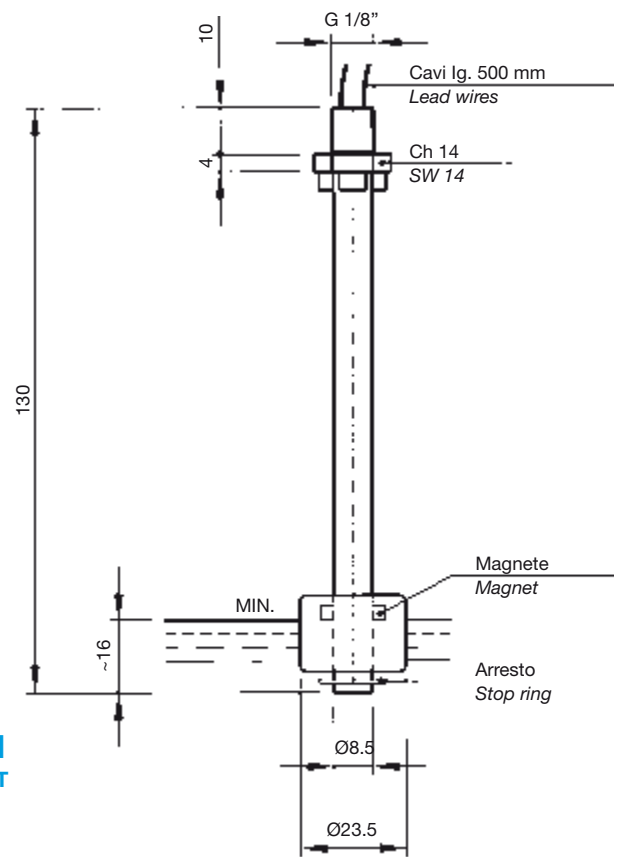
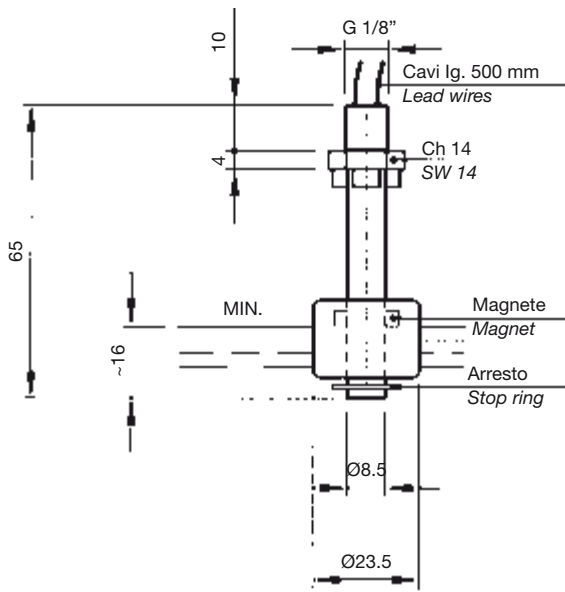

LEM6CN
NC CONTACT

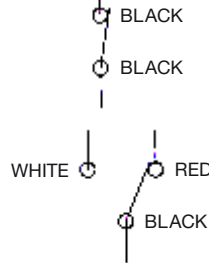

LEM6LN
NC CONTACT

LEM6LNCS
SPDT CONTACT

IMPIEGO

Sono stati studiati per controllare il minimo o il massimo livello di un liquido in un serbatoio e per inviare a distanza un segnale elettrico. A seconda dei tipi, devono essere montati verticalmente sul coperchio del serbatoio in modo che il galleggiante disti almeno 50 mm. dalle pareti metalliche.

DATI TECNICI COMUNI

Campo di temperatura	-10°+80°C
Pressione massima	5 Bar
Peso specifico fluido	≥ 0,7
Viscosità max. del fluido	150 cSt
Materiali	Nylon nero monocorpo Galleggiante in resina espansa NBR

DATI TECNICI VERSIONE CONTATTO NC

Potenza commutabile in CC	10 W
Potenza commutabile in CA	10 VA
Intensità di corrente	0,5A (resistivi)
Tensione massima di lavoro	220 V - 50 Hz
Tensione di breakdown	300 Vcc
Capacità dei contatti aperti	0,2 pF
Resistenza d'isolamento	10 ¹⁰ Ohm

DATI TECNICI VERSIONE CONTATTO SPDT E NA

Potenza commutabile in CC	3 W
Potenza commutabile in CA	3 VA
Intensità di corrente	0,25A (resistivi)
Tensione massima di lavoro	175 Vcc
Tensione di breakdown	200 Vcc
Capacità dei contatti aperti	1 pF
Resistenza d'isolamento	10 ⁹ Ohm

PER CARICHI INDUTTIVI IMPIEGARE CIRCUITO DI PROTEZIONE.

USE

This series of electromagnetic level switches has been designed to check the minimum or maximum level of a liquid in a tank and send an electric signal to a remote board in case the fluid goes over or under the set levels. These level switches should be fixed vertically on the cover of the tank, with the float at least 50 mm far from metal walls.

COMMON SPECIFICATIONS

Temperature range	-10°+80°C
Maximum pressure	5 Bar
Fluid specific gravity	≥ 0,7
Max. fluid viscosity	150 cSt
Material	Compact body in black nylon NBR float

NC CONTACT EXECUTION

Switching capacity in DC	10 W
Switching capacity in AC	10 VA
Current	0,5A (resistive)
Voltage	220 V - 50 Hz
Breakdown voltage	300 Vdc
Capacitance	0,2 pF
Insulation resistance	10 ¹⁰ Ohm

SPDT AND NO CONTACT EXECUTION

Switching capacity in DC	3 W
Switching capacity in AC	3 VA
Current	0,25A (resistive)
Voltage	175 Vdc
Breakdown voltage	200 Vdc
Capacitance	1 pF
Insulation resistance	10 ⁹ Ohm

WITH INDUCTIVE LOADS A PROTECTION CIRCUIT IS TO BE USED.

LIVELLOSTATI ELETTROMAGNETICI - ATOSSICI

Float level switches - Nontoxic

LEM6...A

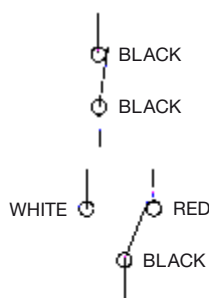
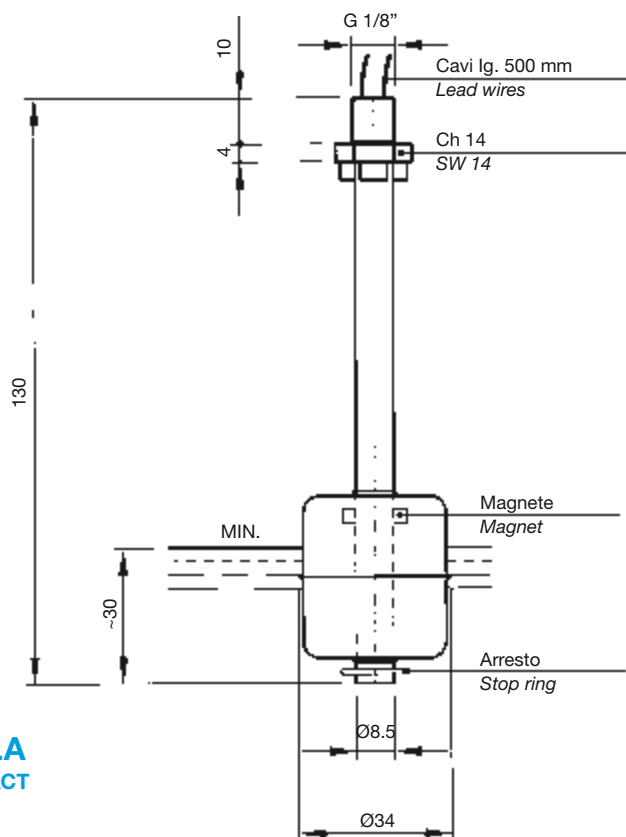
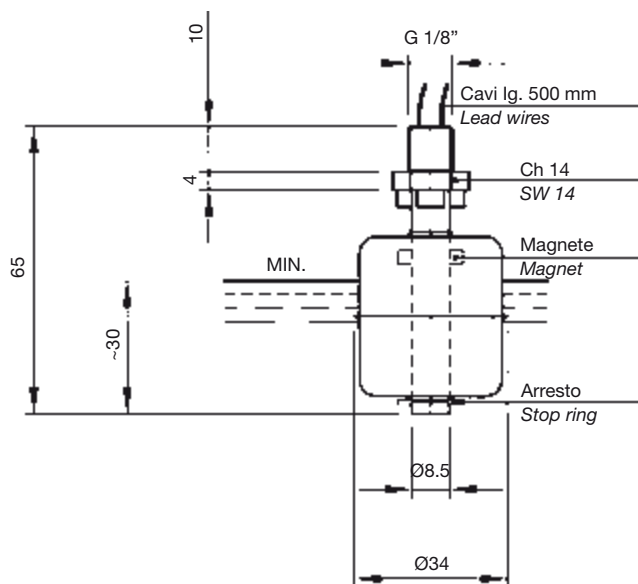

LEM6CA
NC CONTACT

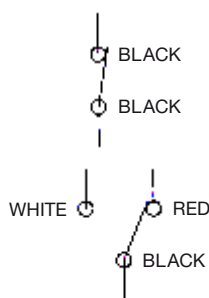

LEM6LA
NC CONTACT

LEM6LASC
SPDT CONTACT

IMPIEGO

Sono stati studiati per controllare il minimo o il massimo livello di un liquido in un serbatoio e per inviare a distanza un segnale elettrico. Particolarmente indicati per applicazioni in campo alimentare. A seconda dei tipi, devono essere montati verticalmente sul coperchio del serbatoio in modo che il galleggiante disti almeno 50 mm. dalle pareti metalliche.

DATI TECNICI COMUNI

Campo di temperatura	-10°+80°C
Pressione massima	5 Bar
Peso specifico fluido	≥ 0,7
Viscosità max. del fluido	150 cSt
Materiali	Corpo atossico bianco, galleggiante inox 316 Esecuzione stagna

DATI TECNICI VERSIONE CONTATTO NC

Potenza commutabile in CC	10 W
Potenza commutabile in CA	10 VA
Intensità di corrente	0,5A (resistivi)
Tensione massima di lavoro	220 V - 50 Hz
Tensione di breakdown	300 Vcc
Capacità dei contatti aperti	0,2 pF
Resistenza d'isolamento	10 ¹⁰ Ohm

DATI TECNICI VERSIONE CONTATTO SPDT E NA

Potenza commutabile in CC	3 W
Potenza commutabile in CA	3 VA
Intensità di corrente	0,25A (resistivi)
Tensione massima di lavoro	175 Vcc
Tensione di breakdown	200 Vcc
Capacità dei contatti aperti	1 pF
Resistenza d'isolamento	10 ⁹ Ohm

PER CARICHI INDUTTIVI IMPIEGARE CIRCUITO DI PROTEZIONE.

USE

This series of electromagnetic level switches has been designed to check the minimum or maximum level of a liquid in a tank and send an electric signal to a remote board in case the fluid goes over or under the set levels. Ideal for food and beverage processing. These level switches should be fixed vertically on the cover of the tank, with the float at least 50 mm far from metal walls.

COMMON SPECIFICATIONS

Temperature range	-10°+80°C
Maximum pressure	5 Bar
Fluid specific gravity	≥ 0,7
Max. fluid viscosity	150 cSt
Material	Nontoxic white body, 316 stainless steel float, sealed manufacture

NC CONTACT EXECUTION

Switching capacity in DC	10 W
Switching capacity in AC	10 VA
Current	0,5A (resistive)
Voltage	220 V - 50 Hz
Breakdown voltage	300 Vdc
Capacitance	0,2 pF
Insulation resistance	10 ¹⁰ Ohm

SPDT AND NO CONTACT EXECUTION

Switching capacity in DC	3 W
Switching capacity in AC	3 VA
Current	0,25A (resistive)
Voltage	175 Vdc
Breakdown voltage	200 Vdc
Capacitance	1 pF
Insulation resistance	10 ⁹ Ohm

WITH INDUCTIVE LOADS A PROTECTION CIRCUIT IS TO BE USED.

LIVELLOSTATI ELETTROMAGNETICI - INOX

Float level switches - Stainless steel

LEM7

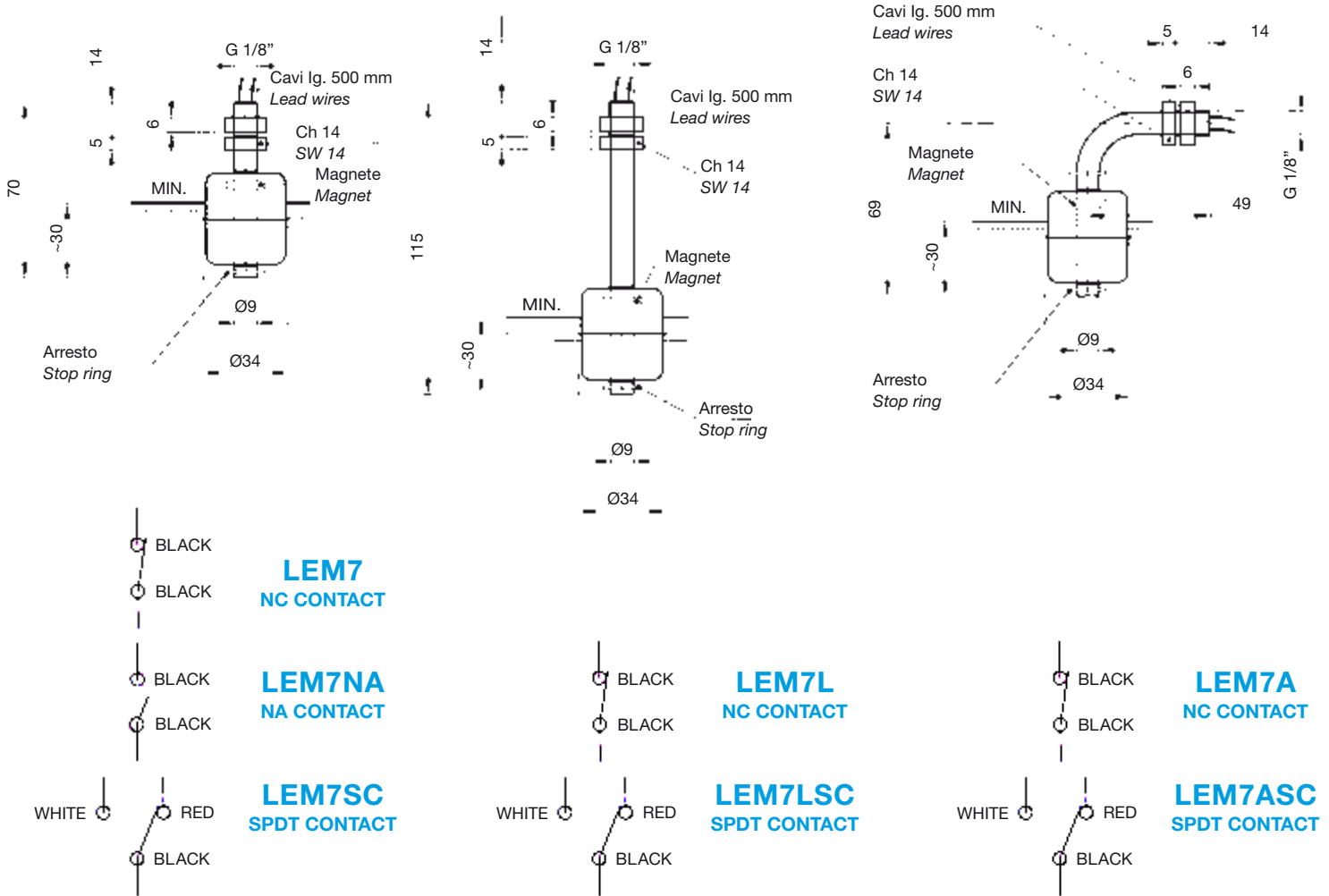

IMPIEGO

Sono stati studiati per controllare il minimo o il massimo livello di un fluido contenuto in un serbatoio e per inviare un segnale elettrico di allarme a distanza. A seconda dei tipi, devono essere montati verticalmente sul coperchio del serbatoio in modo che il galleggiante disti almeno 50 mm. dalle pareti metalliche.

DATI TECNICI COMUNI

Campo di temperatura	-10°+80°C
Pressione massima	10 Bar
Peso specifico fluido	≥ 0,7
Viscosità max. del fluido	150 cSt

DATI TECNICI VERSIONE CONTATTO NC

Potenza commutabile in CC	10 W
Potenza commutabile in CA	10 VA
Intensità di corrente	0,5A (resistivi)
Tensione massima di lavoro	220 V - 50 Hz
Tensione di breakdown	300 Vcc
Capacità dei contatti aperti	0,2 pF
Resistenza d'isolamento	10 ¹⁰ Ohm

DATI TECNICI VERSIONE CONTATTO SPDT E NA

Potenza commutabile in CC	3 W
Potenza commutabile in CA	3 VA
Intensità di corrente	0,25A (resistivi)
Tensione massima di lavoro	175 Vcc
Tensione di breakdown	200 Vcc
Capacità dei contatti aperti	1 pF
Resistenza d'isolamento	10 ⁹ Ohm

PER CARICHI INDUTTIVI IMPIEGARE CIRCUITO DI PROTEZIONE.

USE

This series of electromagnetic level switches has been designed to check the minimum or maximum level of a fluid in a tank and send an electric signal to a remote board in case the fluid goes over or under the set levels. These level switches should be fixed vertically on the cover of the tank, with the float at least 50 mm far from metal walls.

COMMON SPECIFICATIONS

Temperature range	-10°+80°C
Maximum pressure	10 Bar
Fluid specific gravity	≥ 0,7
Max. fluid viscosity	150 cSt

NC CONTACT EXECUTION

Switching capacity in DC	10 W
Switching capacity in AC	10 VA
Current	0,5A (resistive)
Voltage	220 V - 50 Hz
Breakdown voltage	300 Vdc
Capacitance	0,2 pF
Insulation resistance	10 ¹⁰ Ohm

SPDT AND NO CONTACT EXECUTION

Switching capacity in DC	3 W
Switching capacity in AC	3 VA
Current	0,25A (resistive)
Voltage	175 Vdc
Breakdown voltage	200 Vdc
Capacitance	1 pF
Insulation resistance	10 ⁹ Ohm

WITH INDUCTIVE LOADS A PROTECTION CIRCUIT IS TO BE USED.

LIVELLOSTATI ELETTROMAGNETICI

Float level switches

LMD - LM

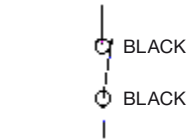
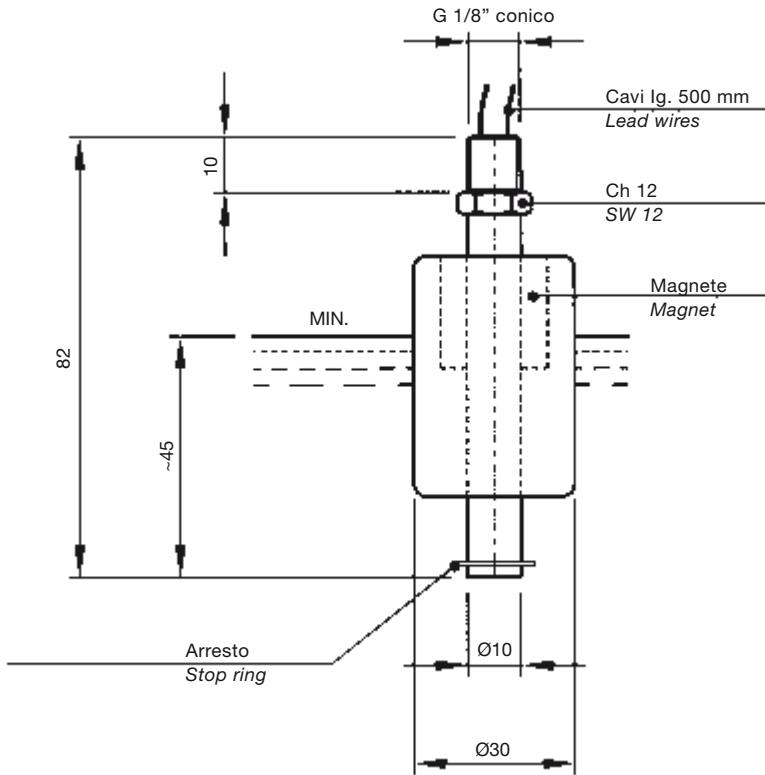

LMD1
NC CONTACT

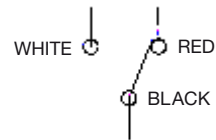

LMD2
SPDT CONTACT

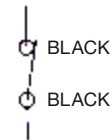
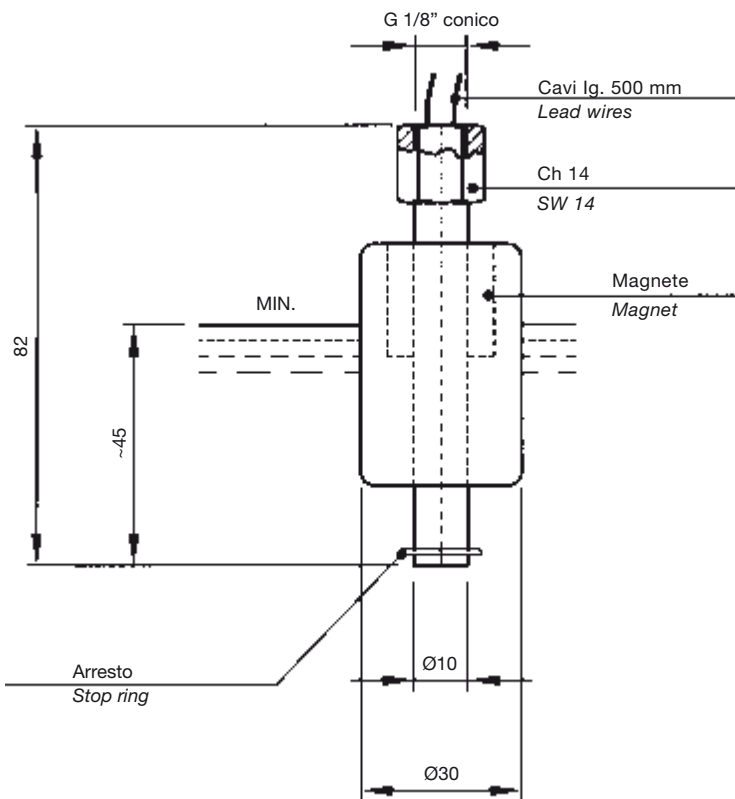

LM1
NC CONTACT

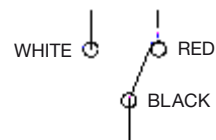

LM2
SPDT CONTACT

MATERIALI: raccordo e tubo in ottone, galleggiante in NBR espansa.

IMPIEGO E DATI TECNICI (vedere pag. 4 - 5 - 6 - 7).

MATERIAL: brass fitting and tube; float in NBR.

APPLICATION AND SPECIFICATIONS (see pages 4 - 5 - 6 - 7).

LIVELLOSTATI ELETTROMAGNETICI SET DA COMPLETARE

Float level switches - Customer assembly kit

LM1P
NC CONTACT

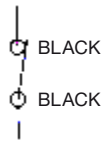

LM1PF
NC CONTACT

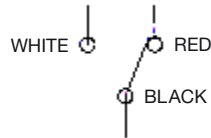

LM2P
SPDT CONTACT

LM2PF
SPDT CONTACT

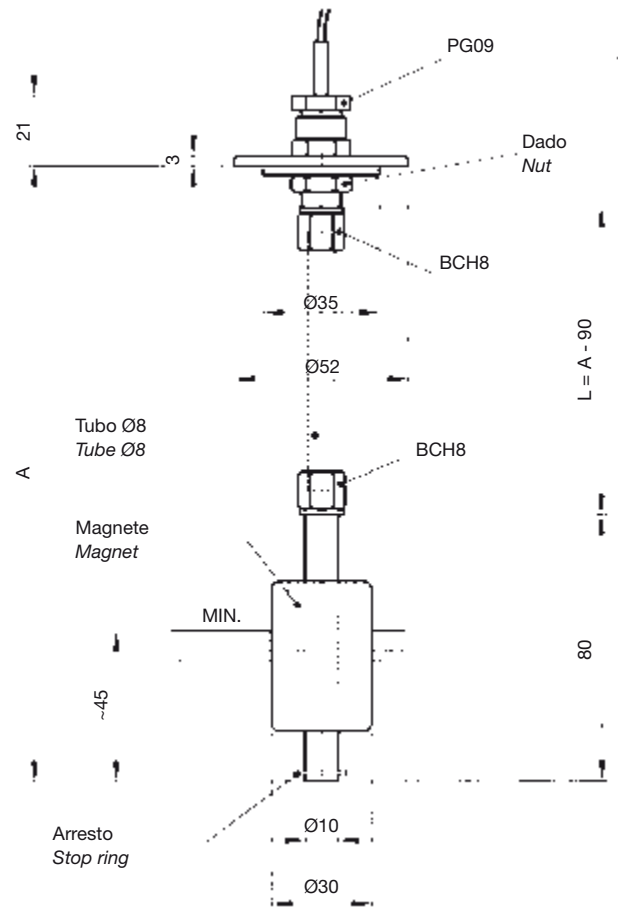
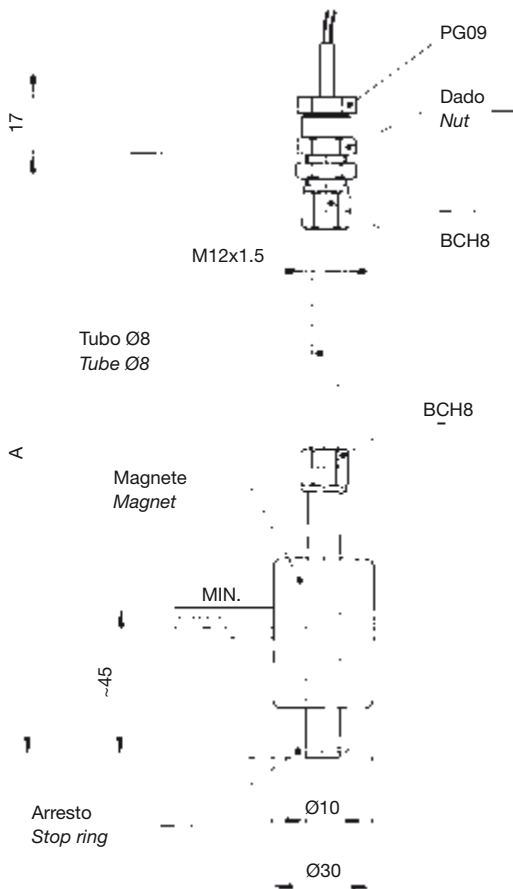

Schema di applicazione
Application chart

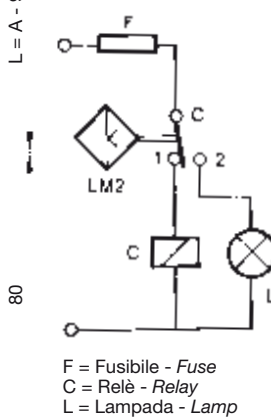

MATERIALI: Modello LM...P attacco e raccordo in ottone; modello LM...PF flangia in alluminio anodizzato e raccordo pressacavo in ottone. Corpo in ottone, bocchettone BCH8 e anello di serraggio ANS8 in ottone, galleggiante NBR.

Modelli forniti con cavi di collegamento lunghezza standard 1000 mm.

IMPIEGO E DATI TECNICI (vedere pag. 4 - 5 - 6 - 7).

N.B. - Per un corretto funzionamento, serrare con cura i raccordi BCH8 in modo da ottenere un buon fissaggio e tenuta del tubo di ottone Ø6x8, onde evitare infiltrazioni nel livellostato e comprometterne il funzionamento.

MATERIAL: LM...P model connection and fitting cable clamp in brass; LM...PF model flange in anodized aluminium and fitting cable clamp in ottone. Body in brass, BCH8 brass fittings, ANS8 brass fastening ring, NBR float.

Models supplied with lead wires standard length 1000 mm.

APPLICATION AND SPECIFICATIONS (see pages 4 - 5 - 6 - 7).

N.B. - Fasten carefully the BCH8 fittings to obtain a firm seal of the Ø 6x8 brass tube and avoid any leakage that could affect the switch correct working.

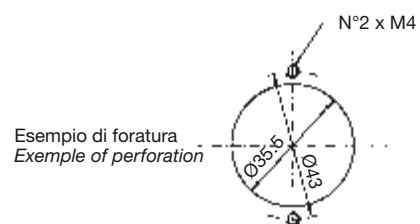

LIVELLOSTATI ELETTROMAGNETICI SET DA COMPLETARE

Float level switches - Customer assembly kit

LM1B LM2B

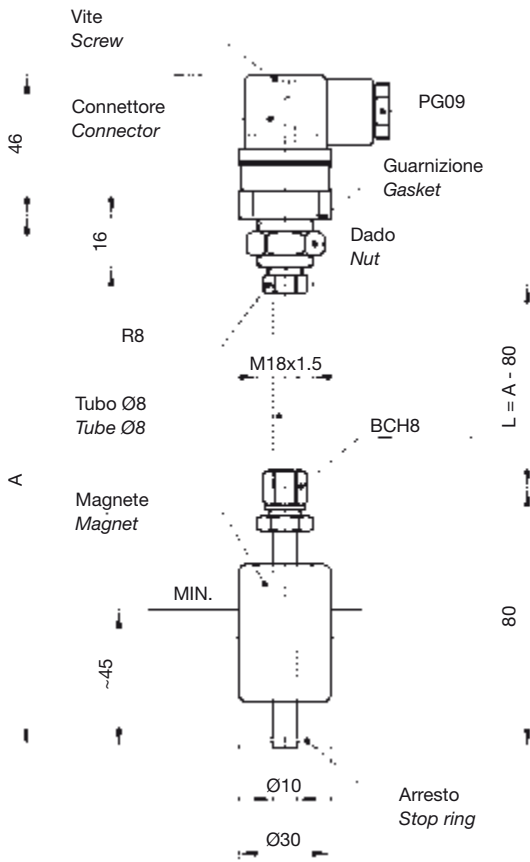

Schema di applicazione
Application chart

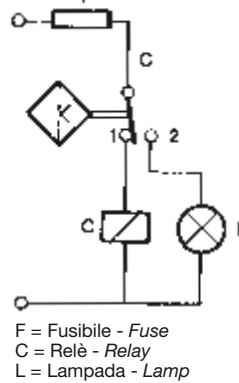

Collegamenti elettrici standard
Standard electrical connection

LM1B-LM1BF

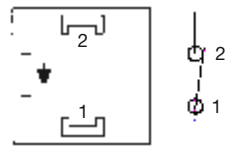

LM2B-LM2BF

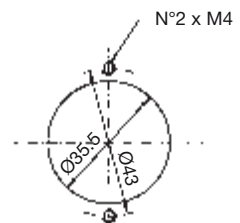
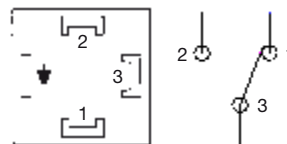

Esempio di foratura
Exemple of perforation

LM1BF LM2BF

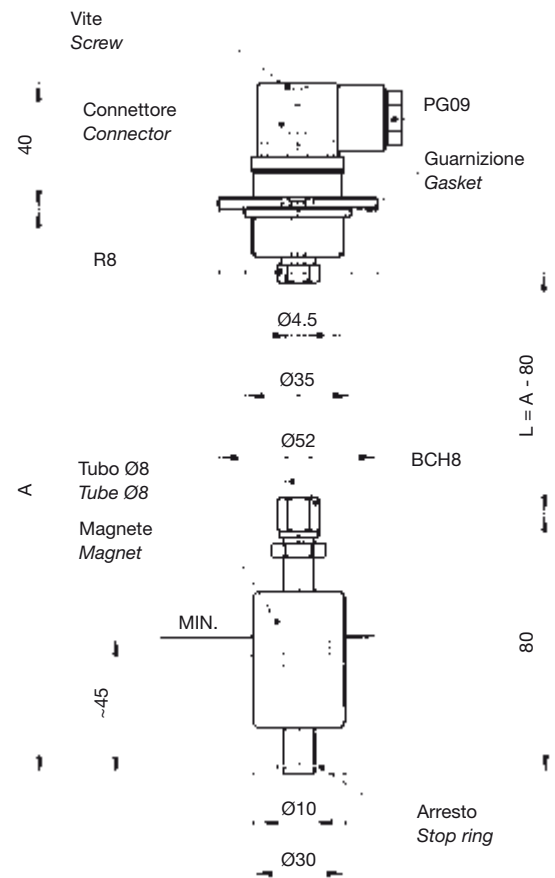

MATERIALI: flangia in alluminio anodizzato, corpo in ottone, bocchettone BCH8 e anello di serraggio ANS8 in ottone, galleggiante in resina espansa NBR.

Modelli forniti con cavi di collegamento lunghezza standard 1000 mm.

IMPIEGO E DATI TECNICI (vedere pag. 4 - 5 - 6 - 7).

N.B. - Per un corretto funzionamento, serrare con cura i raccordi BCH8 e R8 in modo da ottenere un buon fissaggio e tenuta del tubo di ottone Ø6x8, onde evitare infiltrazioni nel livellostato e comprometterne il funzionamento.

MATERIAL: flange in anodized aluminium, brass body, BCH8 fittings and ANS8 fastening ring in brass, NBR float.

Models supplied with lead wires standard length 1000 mm.

APPLICATION AND SPECIFICATIONS (see pages 4 - 5 - 6 - 7).

N.B. - Fasten carefully the BCH8 and the R8 fittings to obtain a firm seal of the Ø6x8 brass tube and avoid any leakage that could affect the switch correct working.

LIVELLOSTATI ELETTROMAGNETICI SET DA COMPLETARE CON LED DI SEGNALAZIONE

Float level switches - Customer assembly kit Equipped with LED

LM1BL (NC CONTACT)

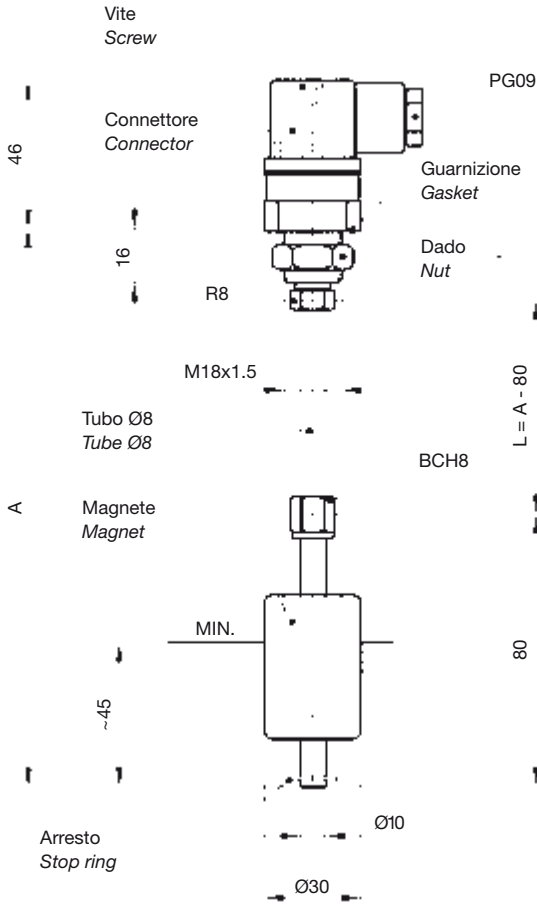

Schema di applicazione
Application chart

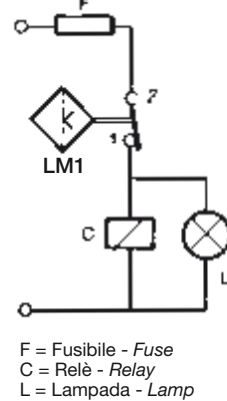

LM1BL-LM1BLF

Collegamenti elettrici standard
Standard electrical connection

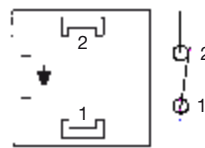

LM1BLF (NC CONTACT)

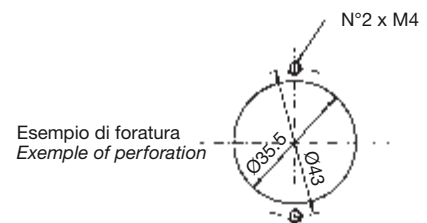
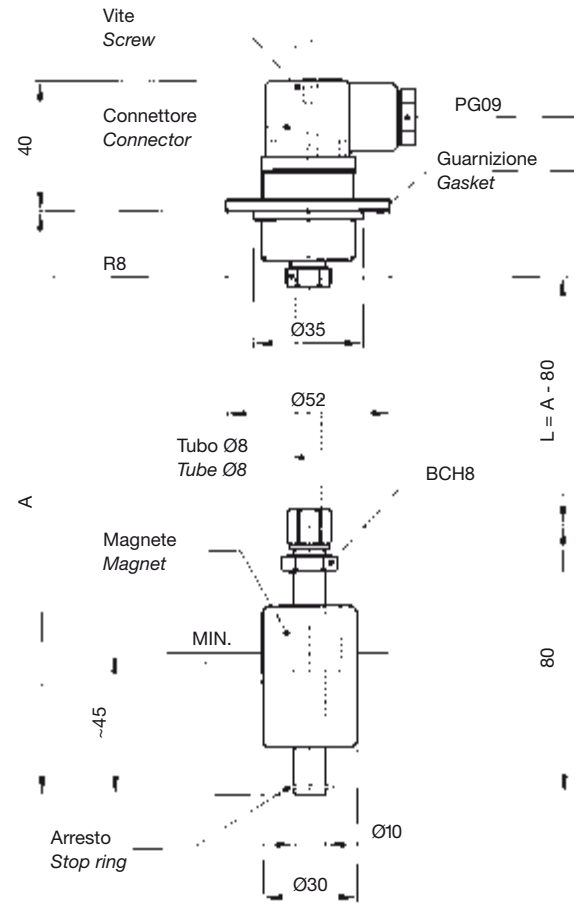

MATERIALI: flangia in alluminio anodizzato, corpo in ottone, bocchettone BCH8 e anello di serraggio ANS8 in ottone, galleggiante in resina espansa NBR.

Modelli forniti con cavi di collegamento lunghezza standard 1000 mm.

IMPIEGO E DATI TECNICI (vedere pag. 4 - 5 - 6 - 7).

N.B. - Per un corretto funzionamento, serrare con cura i raccordi BCH8 e R8 in modo da ottenere un buon fissaggio e tenuta del tubo di ottone Ø 6x8, onde evitare infiltrazioni nel livellostato e comprometterne il funzionamento.

Negli ordini indicare la tensione del LED 24-110-220 Vca.

MATERIAL: flange in anodized aluminium, brass body, BCH8 fittings and ANS8 fastening ring in brass, NBR float.

Models supplied with lead wires standard length 1000 mm.

APPLICATION AND SPECIFICATIONS (see pages 4 - 5 - 6 - 7).

N.B. - Fasten carefully the BCH8 and the R8 fittings to obtain a firm seal of the Ø 6x8 brass tube and avoid any leakage that could affect the switch correct working.

When ordering, indicate the LED voltage 24-110-220 Vac.

LIVELLOSTATI ELETTROMAGNETICI SET DA COMPLETARE

Float level switches - Customer assembly kit

LM1BFP LM2BFP

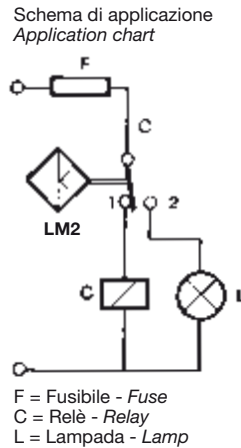
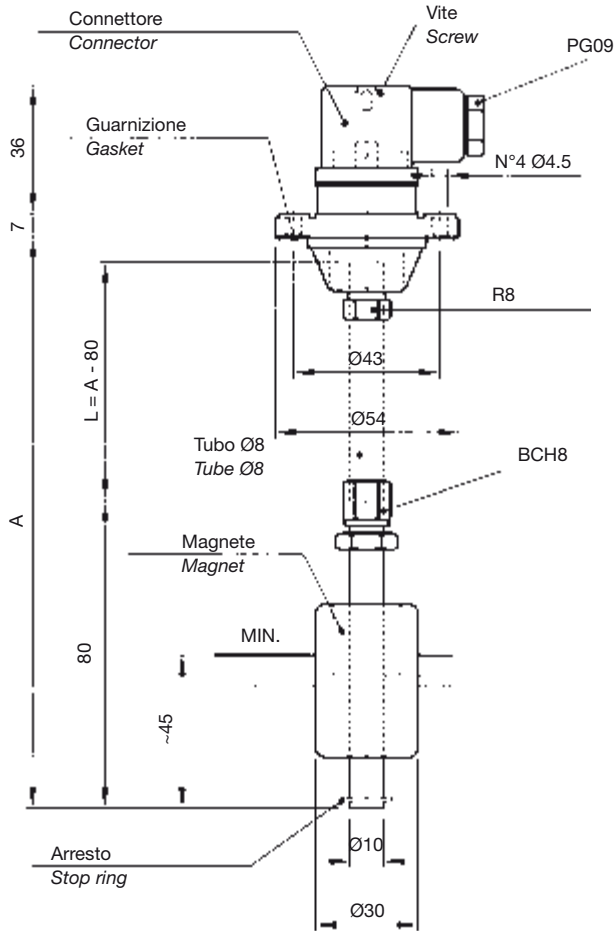

Collegamenti elettrici standard
Standard electrical connection

LM1BFP-LM1TBP

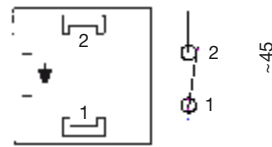

LM2BFP-LM2TBP

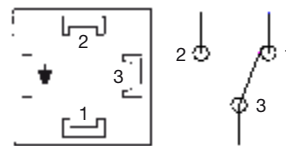

LM1TBP LM2TBP

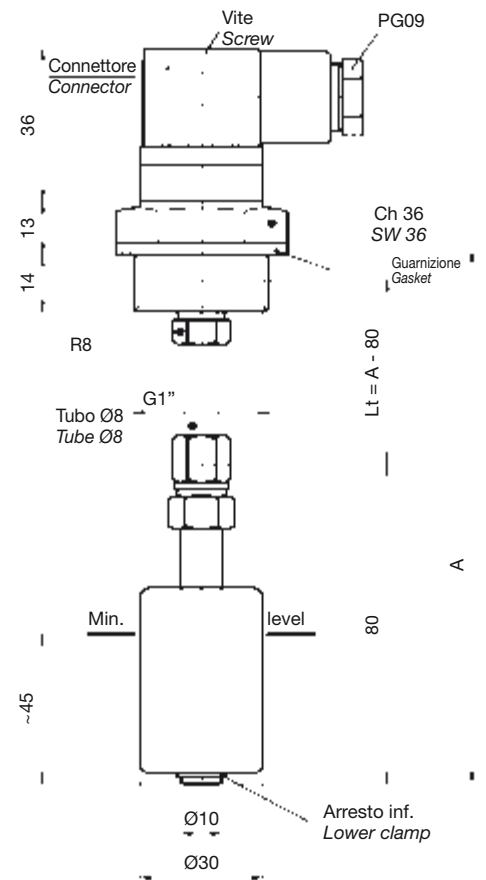

MATERIALI: flangia in termoplastico, corpo in ottone, bocchettone BCH8 e anello di serraggio ANS8 in ottone, galleggiante in resina espansa NBR.

Modelli forniti con cavi di collegamento lunghezza standard 1000 mm.

IMPIEGO E DATI TECNICI (vedere pag. 4 - 5 - 6 - 7).

N.B. - Per un corretto funzionamento, serrare con cura i raccordi BCH8 e R8 in modo da ottenere un buon fissaggio e tenuta del tubo di ottone Ø 6x8, onde evitare infiltrazioni nel livellostato e comprometterne il funzionamento.

MATERIAL: flange in thermoplastic, brass body, BCH8 fittings and ANS8 fastening ring in brass, NBR float.

Models supplied with lead wires standard length 1000 mm.

APPLICATION AND SPECIFICATIONS (see pages 4 - 5 - 6 - 7).

N.B. - Fasten carefully the BCH8 and the R8 fittings to obtain a firm seal of the Ø 6x8 brass tube and avoid any leakage that could affect the switch correct working.

LIVELLOSTATI ELETTROMAGNETICI - SET DA COMPLETARE

Float level switches - Customer assembly kit

LM1TB LM2TB

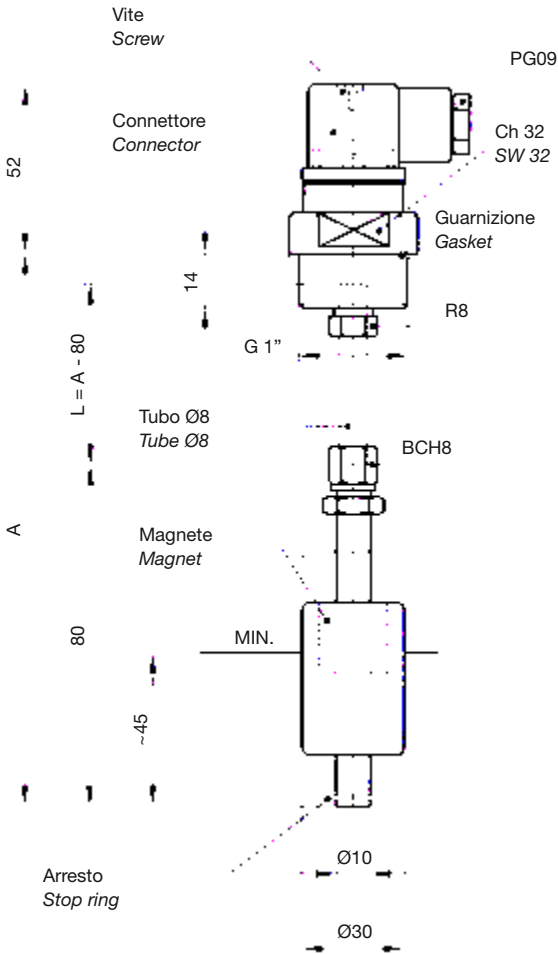

Schema di applicazione
Application chart

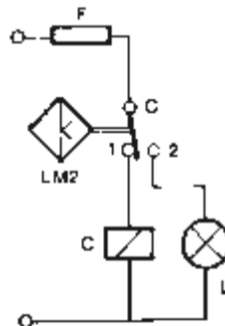

F = Fusibile - Fuse
C = Relè - Relay
L = Lampada - Lamp

Collegamenti elettrici standard
Standard electrical connection

LM1TB LM1TBL

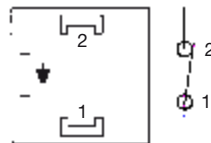

LM2TB

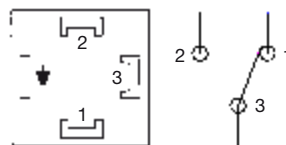

CON LED DI SEGNALEZIONE with LED LM1TBL

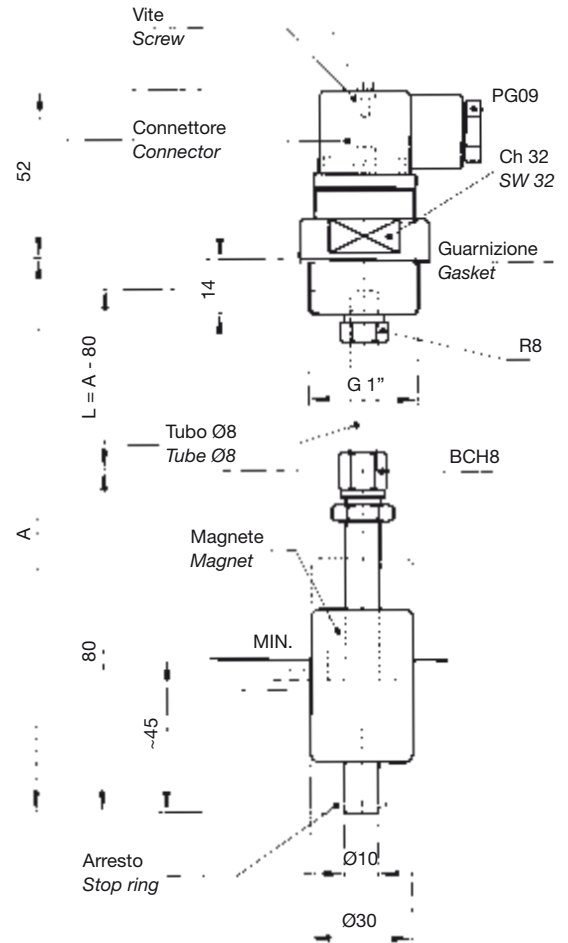

MATERIALI: flangia filettata G1" in alluminio anodizzato, raccordo R8 in ottone nichelato, bicono B8 e bocchettone BCH8 in ottone, anello di serraggio ANS8 in ottone; corpo di ottone; galleggiante NBR.

Modelli forniti con cavi di collegamento lunghezza standard 1000 mm.

IMPIEGO E DATI TECNICI (vedere pag. 4 - 5 - 6 - 7).

N.B. - Per un corretto funzionamento, serrare con cura i due raccordi BCH8 e R8, in modo da ottenere un buon fissaggio e tenuta del tubo di ottone Ø 6x8, onde evitare infiltrazioni nel livellostato e comprometterne il funzionamento.

Negli ordini indicare la tensione del LED 24-110-220 Vca.

MATERIAL: G1" threaded flange in anodized aluminium; R8 fitting in nickel-plated brass; B8 bicone, BCH8 union fittings and ANS8 fastening ring in brass; brass body; NBR float.

Models supplied with lead wires standard length 1000 mm.

APPLICATION AND SPECIFICATIONS (see pages 4 - 5 - 6 - 7).

N.B. - Fasten carefully the BCH8 and the R8 fittings to obtain a firm seal of the Ø 6x8 brass tube and avoid any leakage that could affect the switch correct working.

When ordering, indicate the LED voltage 24-110-220 Vac.

LIVELLOSTATI ELETTROMAGNETICI - SET DA COMPLETARE CON TERMOSTATO FISSO

*Float level switches - Customer assembly kit
Equipped with fixed thermostat*

LM1FT...

LM1T...

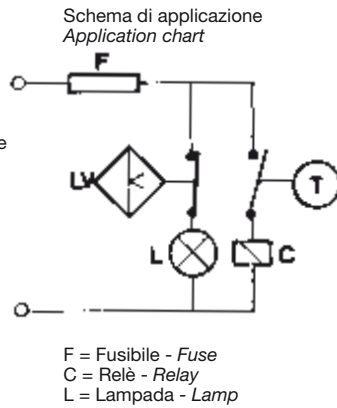
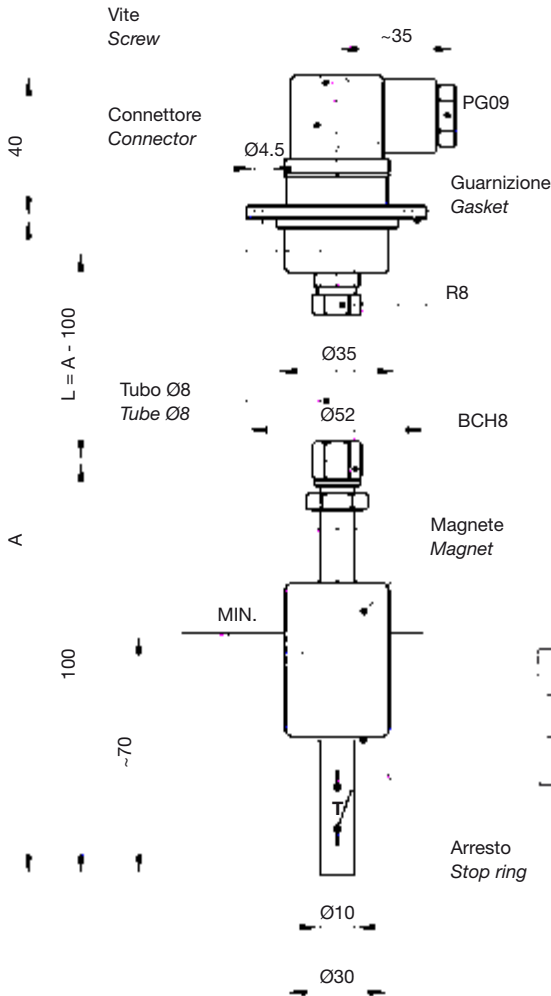

LM1FT-LM1T

Collegamenti elettrici standard
Standard electrical connection

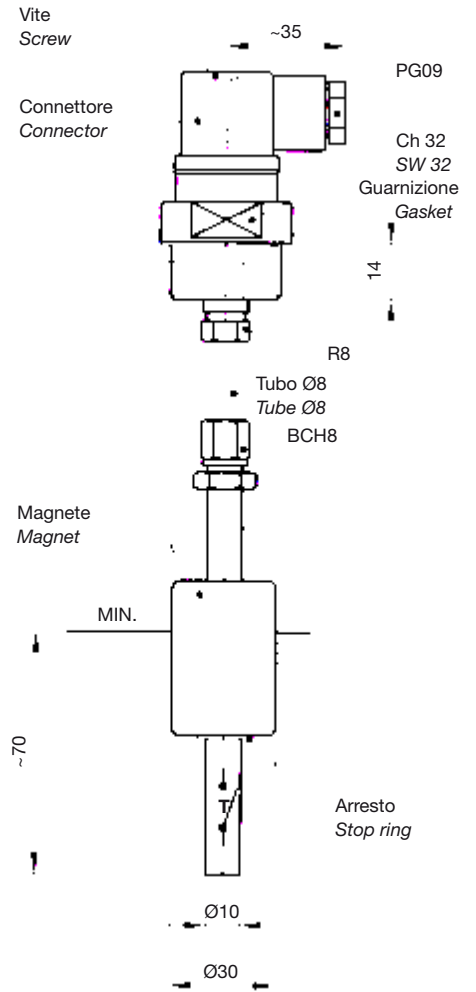
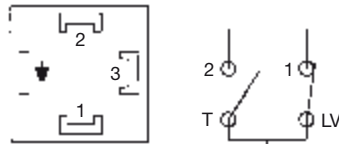

Esempio di ordinazione: LM1FT50 (50°C)
Ordering example:

Sono disponibili le seguenti temperature:
40° - 50° - 60° - 70° - 80°C

MATERIALI: flangia in alluminio anodizzato, corpo in ottone, bocchettone BCH8 e anello di serraggio ANS8 in ottone, galleggiante in resina espansa NBR, termostato bimetallico fisso con contatto NA (V 220/50 Hz - 0,5 A resistivi), differenziale $\Delta T = 7^\circ C$.

Modelli forniti con cavi di collegamento lunghezza standard 1000 mm.

IMPIEGO E DATI TECNICI (vedere pag. 4 - 5 - 6 - 7).

N.B. - Per un corretto funzionamento, serrare con cura i raccordi BCH8 e R8 in modo da ottenere un buon fissaggio e tenuta del tubo di ottone $\varnothing 6 \times 8$, onde evitare infiltrazioni nel livellostatato e comprometterne il funzionamento.

Negli ordini indicare la temperatura desiderata.

Thermostat settings:
40° - 50° - 60° - 70° - 80°C

MATERIAL: threaded flange in anodized aluminium, brass body, BCH8 fittings and ANS8 fastening ring in brass, NBR float, bimetallic fixed thermostat with NO contact (V 220/50 Hz - 0,5 A resistive), differential $\Delta T = 7^\circ C$.

Models supplied with lead wires standard length 1000 mm.

APPLICATION AND SPECIFICATIONS (see pages 4 - 5 - 6 - 7).

N.B. - Fasten carefully the BCH8 and the R8 fittings to obtain a firm seal of the $\varnothing 6 \times 8$ brass tube and avoid any leakage that could affect the switch correct working.

When ordering, please indicate the temperature required.

LIVELLOSTATI ELETTROMAGNETICI - INOX

SET DA COMPLETARE

Float level switches - Stainless steel

Customer assembly kit

LM1PI
LM2PI

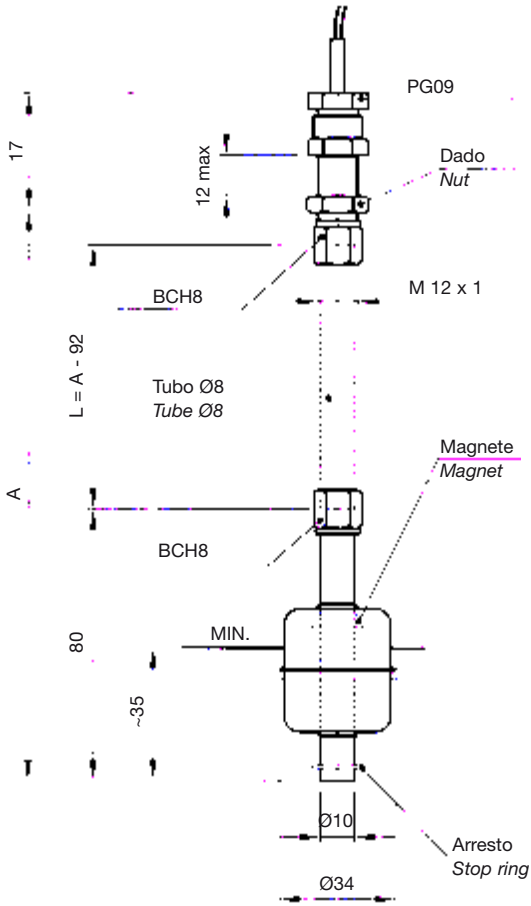

Schema di applicazione
Application chart

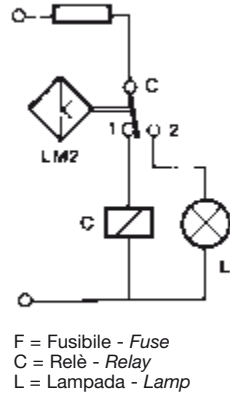

Collegamenti elettrici standard
Standard electrical connection

LM1PI-LM1BFI

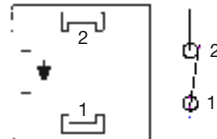

LM2PI-LM2BFI

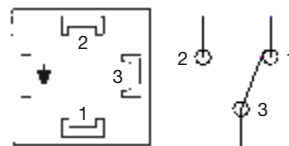

LM1BFI
LM2BFI

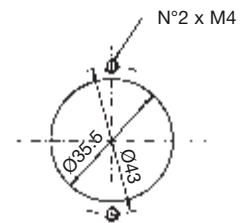
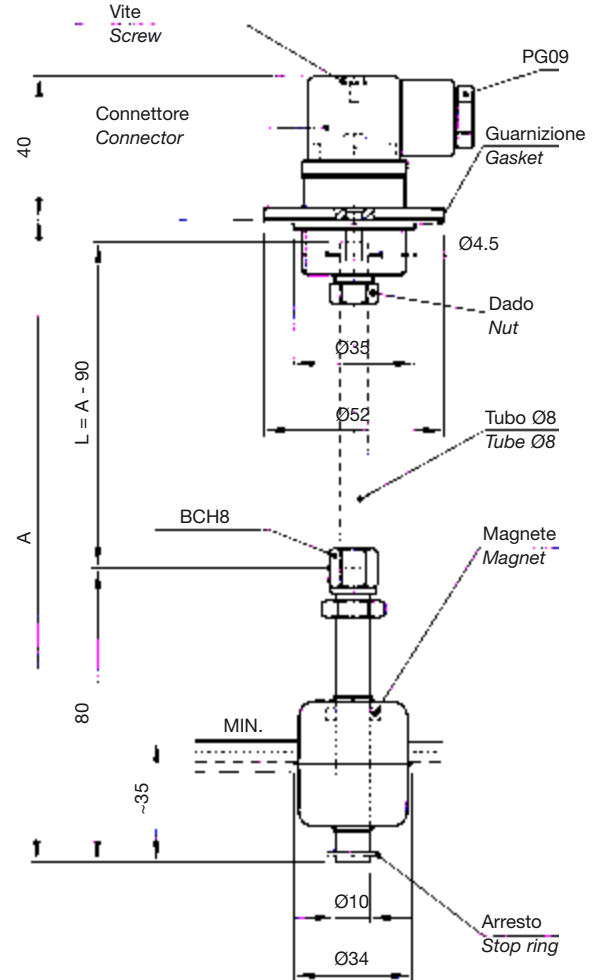

Esempio di foratura
Exemple of perforation

MATERIALI: modello LM...PI attacco filettato, modello LM...BFI flangia, raccordo R8, bicono B8, bocchettone BCH8, anello di serraggio ANS8, corpo e galleggiante in acciaio inox AISI 316.

Modelli forniti con cavi di collegamento lunghezza standard 1000 mm.

IMPIEGO E DATI TECNICI (vedere pag. 4 - 5 - 6 - 7).

N.B. - Per un corretto funzionamento, serrare con cura i raccordi BCH8 e R8 in modo da ottenere un buon fissaggio e tenuta del tubo di acciaio inox Ø 6x8, onde evitare infiltrazioni di fluido nel livellostato e comprometterne il funzionamento.

MATERIAL: LM...PI model thread, connection LM...BFI model flange, R8 fitting, B8 bicone, BCH8 union, ANS8 fastening ring, body and float in AISI 316 stainless steel.

Models supplied with lead wires standard length 1000 mm.

APPLICATION AND SPECIFICATIONS (see pages 4 - 5 - 6 - 7).

N.B. - Fasten carefully the BCH8 and the R8 fittings to obtain a firm seal of the Ø 6x8 stainless steel tube and avoid any leakage that could affect the switch correct working.

LIVELLOSTATI ELETTROMAGNETICI

Float level switches

LM1A... LM2A...

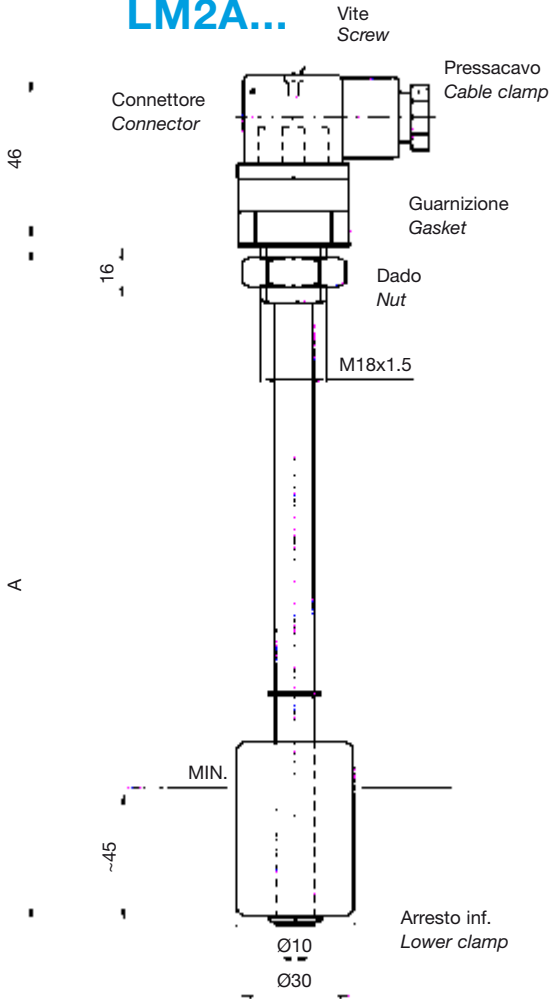

Collegamenti elettrici standard
Standard electrical connection

LM1A

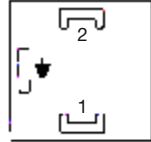

LM2A

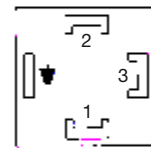

LMM1A

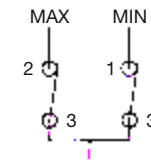
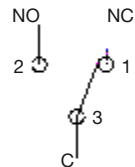
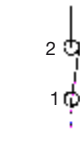
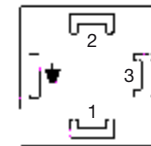

LMM1A...B...

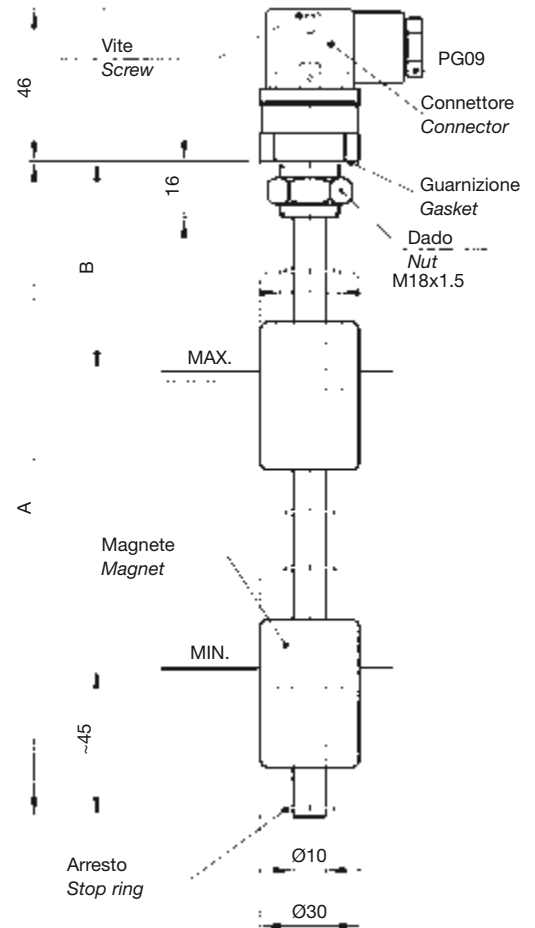

MATERIALI: flangia filettata in alluminio anodizzato, tubo in ottone, molla e anelli di arresto in bronzo, galleggiante in resina espansa NBR.

IMPIEGO E DATI TECNICI
(vedere pag. 4 - 5 - 6 - 7).

N.B. - A richiesta, forniamo lunghezze superiori, fino a 1500 mm, oppure diverse da quelle indicate in tabella.

MATERIAL: threaded flange in anodized aluminium, brass stem, spring and stop rings in bronze, NBR float.

APPLICATION AND SPECIFICATIONS
(see pages 4 - 5 - 6 - 7).

N.B. - Customized lengths can be supplied on request. Max. length 1500 mm.

LM1A...		LM2A...		LMM1A...B...		
TIPO Model	A	TIPO Model	A	TIPO Model	A	B
LM1A100	100	LM2A100	100			
LM1A150	150	LM2A150	150			
LM1A200	200	LM2A200	200	LMM1A200B60	200	60
LM1A250	250	LM2A250	250	LMM1A250B60	250	60
LM1A300	300	LM2A300	300	LMM1A300B60	300	60
LM1A350	350	LM2A350	350	LMM1A350B60	350	60
LM1A400	400	LM2A400	400	LMM1A400B70	400	70
LM1A450	450	LM2A450	450	LMM1A450B70	450	70
LM1A500	500	LM2A500	500	LMM1A500B80	500	80

LIVELLOSTATI ELETTROMAGNETICI

Float level switches

LM1FA... LM2FA...

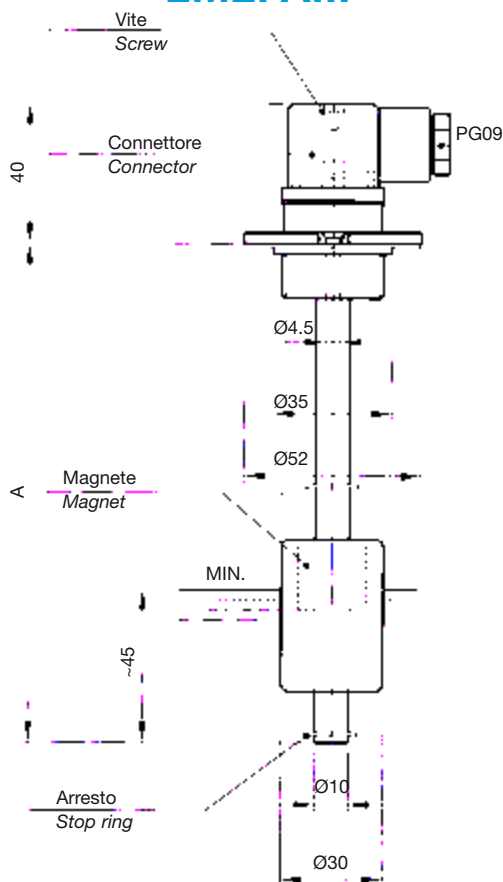

Collegamenti elettrici standard
Standard electrical connection

LM1FA

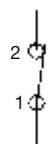
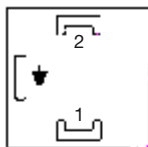

LM2FA

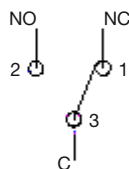
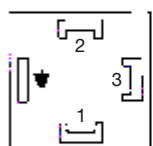

LMM1FA

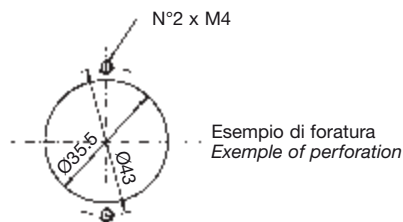
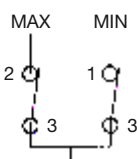
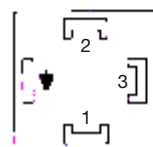

LMM1FA...B...

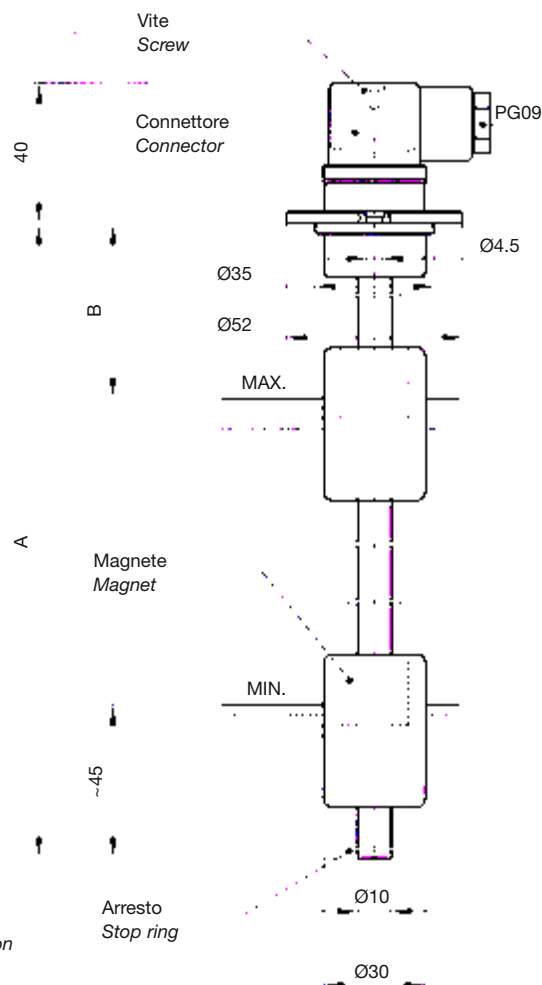

MATERIALI: flangia in alluminio anodizzato, tubo in ottone, molla e anelli di arresto in bronzo, galleggiante in resina espansa NBR.

IMPIEGO E DATI TECNICI (vedere pag. 4 - 5 - 6 - 7).

N.B. - A richiesta, forniamo lunghezze superiori, fino a 1500 mm, oppure diverse da quelle indicate in tabella.

 Disponibili in versione conforme alla Direttiva ATEX 94/9/CE in esecuzione a sicurezza intrinseca con stringa di certificazione II 1/2 G Ex ia IIB T6.

MATERIAL: flange in anodized aluminium, brass stem, spring and stop rings in bronze, NBR float.

APPLICATION AND SPECIFICATIONS (see page 4 - 5 - 6 - 7).

N.B. - Customized lengths can be supplied on request. Max. length 1500 mm.

 Executions also available in accordance with the Directive ATEX 94/9/EC on intrinsic safety equipment with marking II 1/2 G Ex ia IIB T6.

LM1FA...		LM2FA...		LMM1FA...B...		
TIPO Model	A	TIPO Model	A	TIPO Model	A	B
LM1FA100	100	LM2FA100	100			
LM1FA150	150	LM2FA150	150			
LM1FA200	200	LM2FA200	200	LMM1FA200B60	200	60
LM1FA250	250	LM2FA250	250	LMM1FA250B60	250	60
LM1FA300	300	LM2FA300	300	LMM1FA300B60	300	60
LM1FA350	350	LM2FA350	350	LMM1FA350B60	350	60
LM1FA400	400	LM2FA400	400	LMM1FA400B70	400	70
LM1FA450	450	LM2FA450	450	LMM1FA450B70	450	70
LM1FA500	500	LM2FA500	500	LMM1FA500B80	500	80

LIVELLOSTATI ELETTROMAGNETICI

Float level switches

LM1TA... LM2TA...

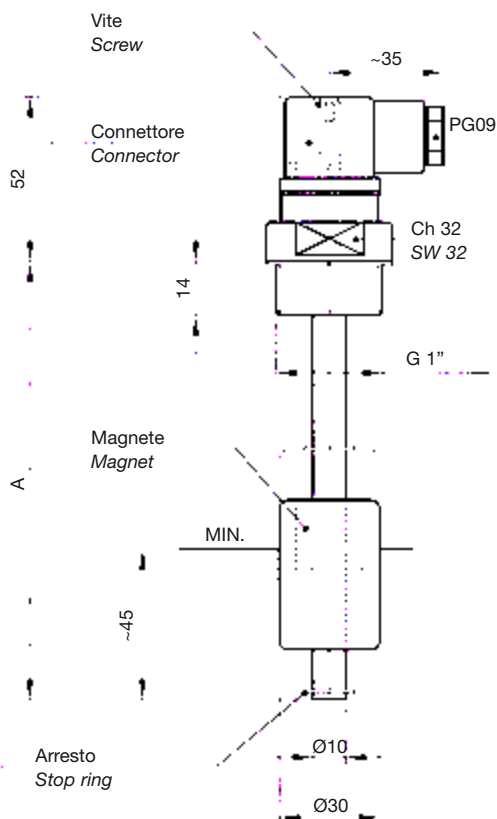

Collegamenti elettrici standard
Standard electrical connection

LM1TA

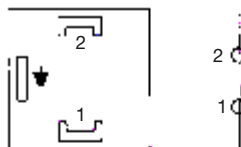

LM2TA

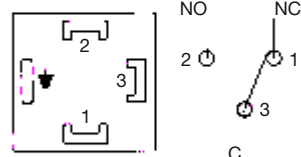

LMM1TA

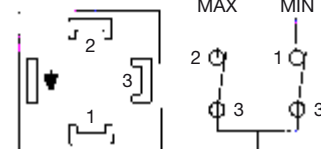

LMM1TA...B...

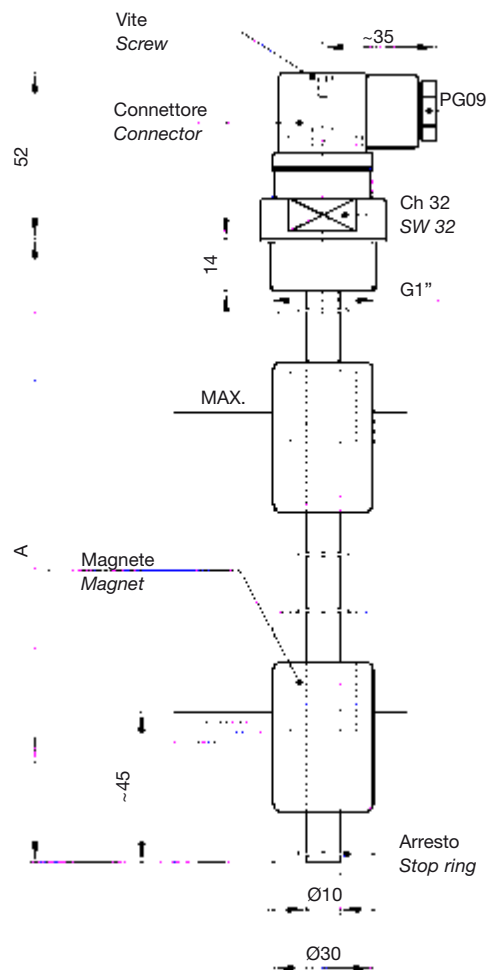

MATERIALI: flangia filettata in alluminio anodizzato, tubo in ottone, molla e anelli di arresto in bronzo, galleggiante in resina espansa NBR.

IMPIEGO E DATI TECNICI (vedere pag. 4 - 5 - 6 - 7).

N.B. - A richiesta, forniamo lunghezze superiori, fino a 1500 mm, oppure diverse da quelle indicate in tabella.

 Disponibili in versione conforme alla Direttiva ATEX 94/9/CE in esecuzione a sicurezza intrinseca con stringa di certificazione II 1/2 G Ex ia IIB T6.

MATERIAL: threaded flange in anodized aluminium, brass stem, spring and stop rings in bronze, NBR float.

APPLICATION AND SPECIFICATIONS (see pages 4 - 5 - 6 - 7).

N.B. - Customized lengths can be supplied on request. Max. length 1500 mm.

 Executions also available in accordance with the Directive ATEX 94/9/EC on intrinsic safety equipment with marking II 1/2 G Ex ia IIB T6.

LM1TA...		LM2TA...		LMM1TA...B...		
TIPO Model	A	TIPO Model	A	TIPO Model	A	B
LM1TA100	100	LM2TA100	100			
LM1TA150	150	LM2TA150	150			
LM1TA200	200	LM2TA200	200	LMM1TA200B60	200	60
LM1TA250	250	LM2TA250	250	LMM1TA250B60	250	60
LM1TA300	300	LM2TA300	300	LMM1TA300B60	300	60
LM1TA350	350	LM2TA350	350	LMM1TA350B60	350	60
LM1TA400	400	LM2TA400	400	LMM1TA400B70	400	70
LM1TA450	450	LM2TA450	450	LMM1TA450B70	450	70
LM1TA500	500	LM2TA500	500	LMM1TA500B80	500	80

LIVELLOSTATI ELETTROMAGNETICI

Float level switches

LM1FPA... LM2FPA...

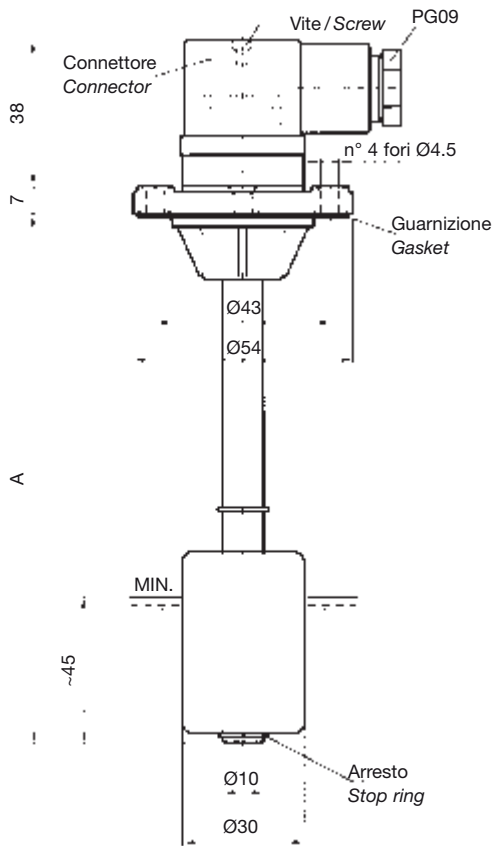

Collegamenti elettrici standard
Standard electrical connection

LM1FPA

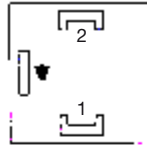

LM2FPA

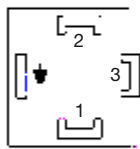

LMM1FPA

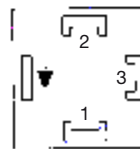

LMM1FPA...B...

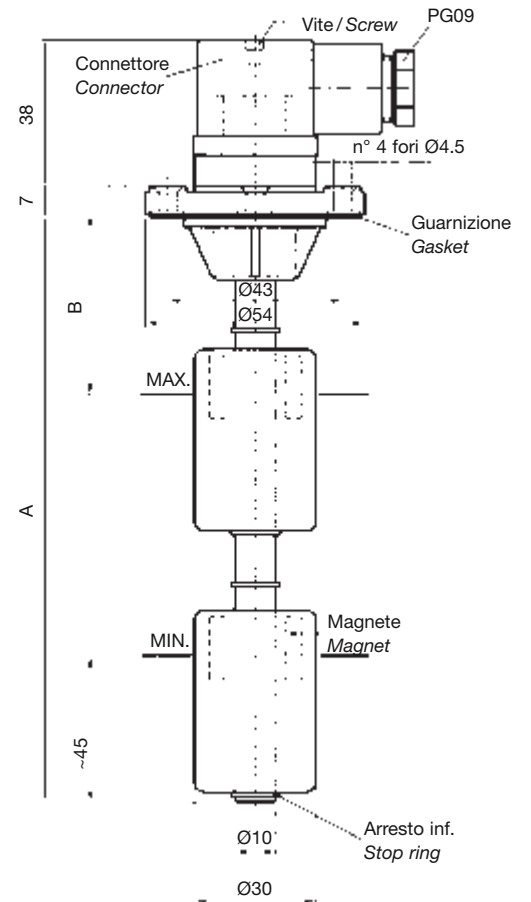

MATERIALI: flangia in termoplastico, tubo in ottone, molla e anelli di arresto in bronzo, galleggiante in resina espansa NBR.

IMPIEGO E DATI TECNICI (vedere pag. 4 - 5 - 6 - 7).

N.B. - A richiesta, forniamo lunghezze superiori, fino a 1500 mm, oppure diverse da quelle indicate in tabella.

MATERIAL: threaded flange in thermoplastic, brass stem, spring and stop rings in bronze, NBR float.

APPLICATION AND SPECIFICATIONS (see page 4 - 5 - 6 - 7).

N.B. - Customized lengths can be supplied on request. Max. length 1500 mm.

LM1FPA...		LM2FPA...		LMM1FPA...B...		
TIPO Model	A	TIPO Model	A	TIPO Model	A	B
LM1FPA100	100	LM2FPA100	100			
LM1FPA150	150	LM2FPA150	150			
LM1FPA200	200	LM2FPA200	200	LMM1FPA200B60	200	60
LM1FPA250	250	LM2FPA250	250	LMM1FPA250B60	250	60
LM1FPA300	300	LM2FPA300	300	LMM1FPA300B60	300	60
LM1FPA350	350	LM2FPA350	350	LMM1FPA350B60	350	60
LM1FPA400	400	LM2FPA400	400	LMM1FPA400B70	400	70
LM1FPA450	450	LM2FPA450	450	LMM1FPA450B70	450	70
LM1FPA500	500	LM2FPA500	500	LMM1FPA500B80	500	80

LIVELLOSTATI ELETTROMAGNETICI

Float level switches

LM1TPA... LM2TPA...

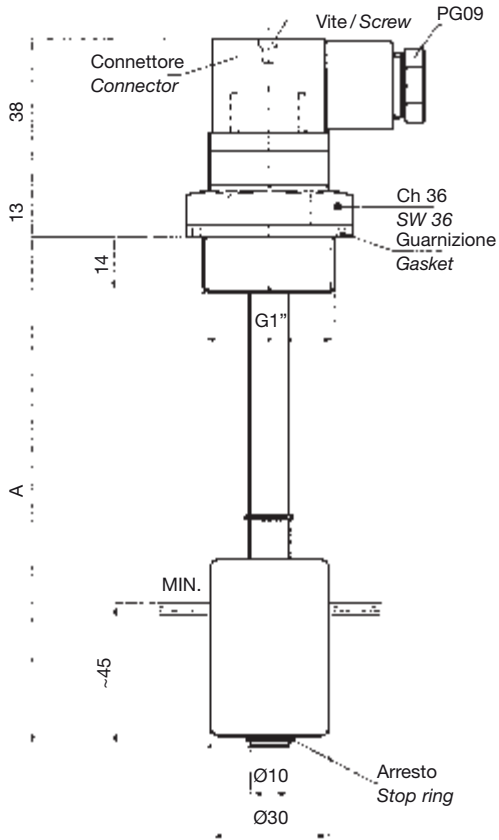

Collegamenti elettrici standard
Standard electrical connection

LM1TPA

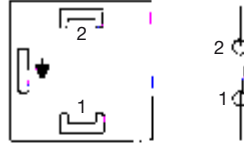

LM2TPA

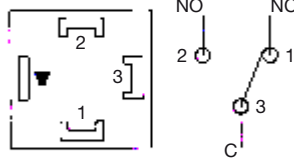

LMM1TPA

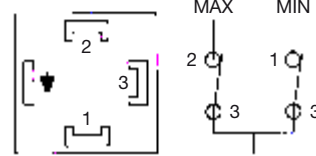

LMM1TPA...B...

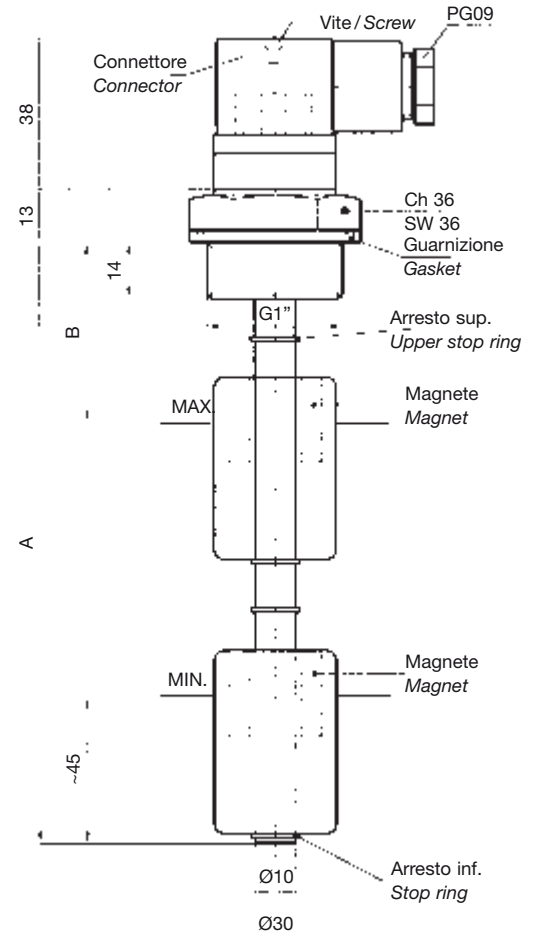

MATERIALI: flangia filettata in termoplastico, tubo in ottone, molla e anelli di arresto in bronzo, galleggiante in resina espansa NBR.

IMPIEGO E DATI TECNICI
(vedere pag. 4 - 5 - 6 - 7).

N.B. - A richiesta, forniamo lunghezze superiori, fino a 1500 mm, oppure diverse da quelle indicate in tabella.

MATERIAL: threaded flange in thermoplastic, brass stem, spring and stop rings in bronze, NBR float.

APPLICATION AND SPECIFICATIONS
(see pages 4 - 5 - 6 - 7).

N.B. - Customized lengths can be supplied on request.
Max. length 1500 mm.

LM1FPA...		LM2FPA...		LMM1FPA...B...		
TIPO Model	A	TIPO Model	A	TIPO Model	A	B
LM1TPA100	100	LM2TPA100	100			
LM1TPA150	150	LM2TPA150	150			
LM1TPA200	200	LM2TPA200	200	LMM1TPA200B60	200	60
LM1TPA250	250	LM2TPA250	250	LMM1TPA250B60	250	60
LM1TPA300	300	LM2TPA300	300	LMM1TPA300B60	300	60
LM1TPA350	350	LM2TPA350	350	LMM1TPA350B60	350	60
LM1TPA400	400	LM2TPA400	400	LMM1TPA400B70	400	70
LM1TPA450	450	LM2TPA450	450	LMM1TPA450B70	450	70
LM1TPA500	500	LM2TPA500	500	LMM1TPA500B80	500	80

LIVELLOSTATI ELETTROMAGNETICI CON LED DI SEGNALAZIONE

Float level switches with LED

LM1LA...

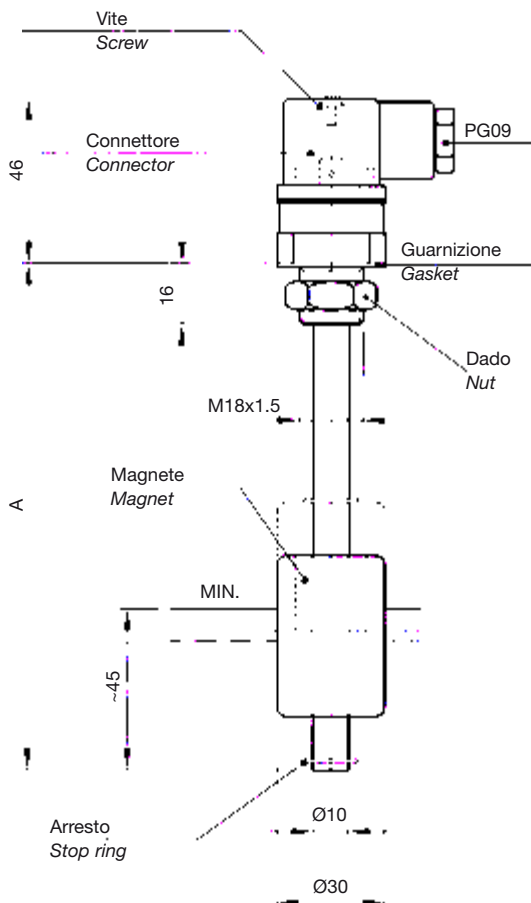

Schema di applicazione
Application chart

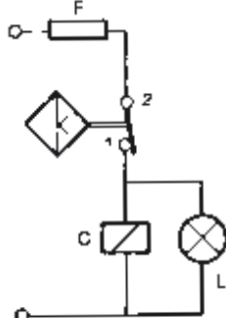

F = Fusibile - Fuse
C = Relè - Relay
L = Lampada - Lamp

LM1LA-LM1LFA

Collegamenti elettrici standard
Standard electrical connection

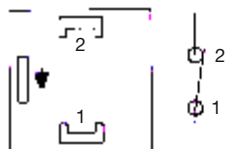

LM1LFA...

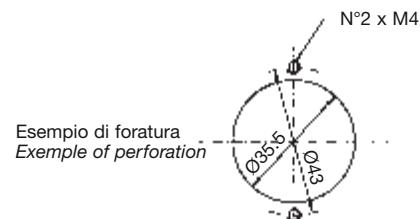
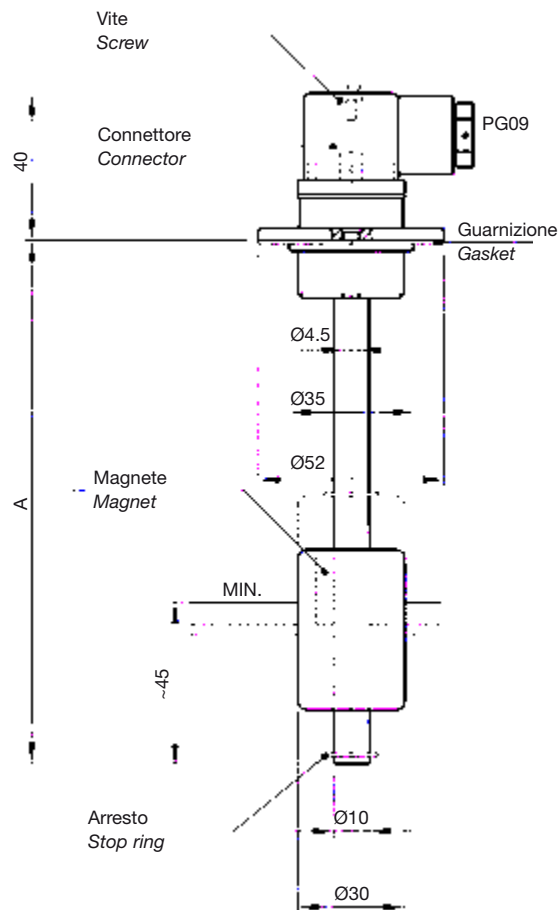

MATERIALI: modello LM1LA... flangia filettata in alluminio anodizzato; modello LM1LFA... flangia in alluminio anodizzato; tubo in ottone, molla e anelli di arresto in bronzo, galleggiante in resina espansa NBR.

IMPIEGO E DATI TECNICI (vedere pag. 4 - 5 - 6 - 7).

N.B. - A richiesta, forniamo lunghezze superiori, fino a 1500 mm, oppure diverse da quelle indicate in tabella.

Negli ordini indicare la tensione del LED 24-110-220 Vca.

MATERIAL: LM1LA... model thread connection in anodized aluminium; LM1LFA... model flange in anodized aluminium; brass stem, spring and stop ring in bronze, NBR float.

APPLICATION AND SPECIFICATIONS (see pages 4 - 5 - 6 - 7).

N.B. - Customized lengths can be supplied on request./Max. length 1500 mm.

When ordering indicate the LED voltage 24-110-220 Vac.

LM1LA...		LM1LFA...	
TIPO Model	A	TIPO Model	A
LM1LA150	150	LM1LFA150	150
LM1LA200	200	LM1LFA200	200
LM1LA250	250	LM1LFA250	250
LM1LA300	300	LM1LFA300	300
LM1LA350	350	LM1LFA350	350
LM1LA400	400	LM1LFA400	400
LM1LA450	450	LM1LFA450	450
LM1LA500	500	LM1LFA500	500

LIVELLOSTATI ELETTROMAGNETICI - MINIMO/VUOTO

Float level switches - Minimum/Drain

LMV1A...

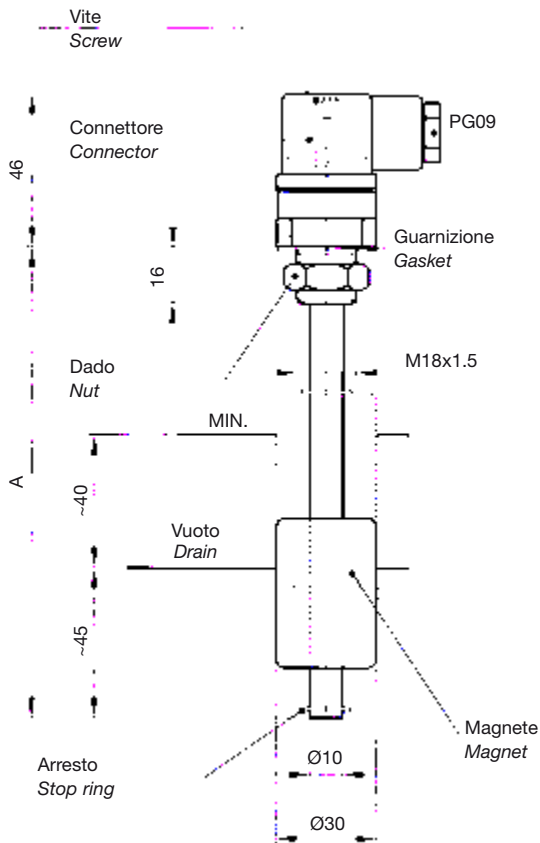

Schema di applicazione
Application chart

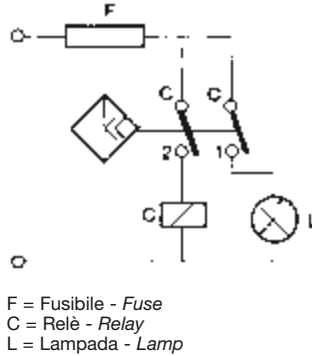

LMV1A-LMV1FA

Collegamenti elettrici standard
Standard electrical connection

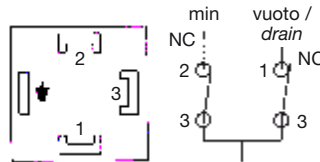

LMV1FA...

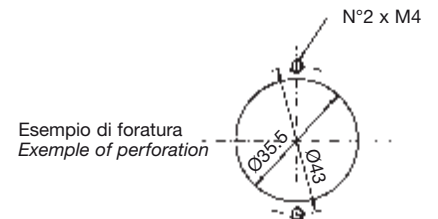
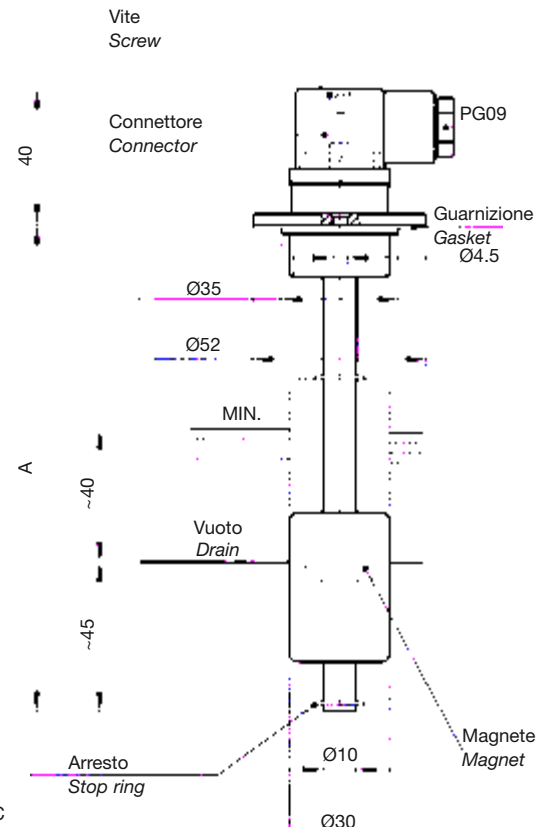

MATERIALI: modello LMV1A... flangia filettata in alluminio anodizzato; modello LMV1FA... flangia in alluminio anodizzato; tubo in ottone, molla e anelli di arresto in bronzo, galleggiante in resina espansa NBR.

IMPIEGO E DATI TECNICI (vedere pag. 4 - 5 - 6 - 7).

N.B. - A richiesta, forniamo lunghezze superiori, fino a 1500 mm, oppure diverse da quelle indicate in tabella.

MATERIAL: LMV1A... model thread connection in anodized aluminium; LMV1FA... model flange in anodized aluminium; brass stem; spring and stop rings in bronze, NBR float.

APPLICATION AND SPECIFICATIONS (see pages 4 - 5 - 6 - 7).

N.B. - Customized lengths can be supplied on request. Max. length 1500 mm.

LMV1A...		LMV1FA...	
TIPO Model	A	TIPO Model	A
LMV1A150	150	LMV1FA150	150
LMV1A200	200	LMV1FA200	200
LMV1A250	250	LMV1FA250	250
LMV1A300	300	LMV1FA300	300
LMV1A350	350	LMV1FA350	350
LMV1A400	400	LMV1FA400	400
LMV1A450	450	LMV1FA450	450
LMV1A500	500	LMV1FA500	500

LIVELLOSTATI ELETTROMAGNETICI

Float level switches

LMA1FA... LMA2FA...

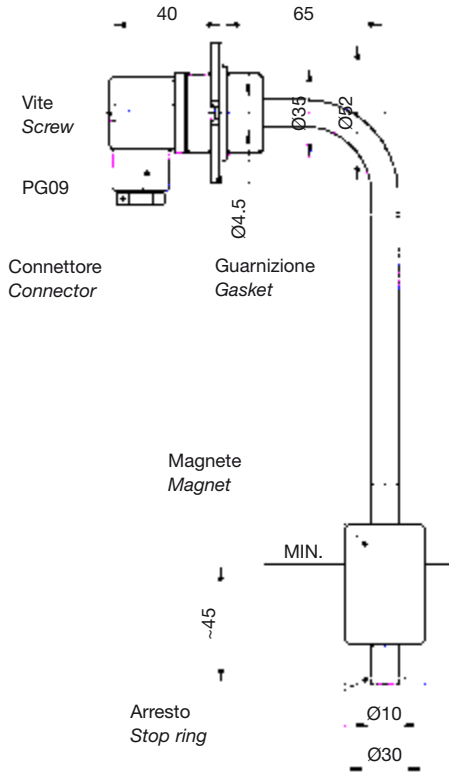

Esempio di foratura
Exemple of perforation

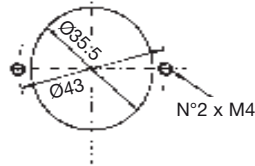

LMMA1FA...B...

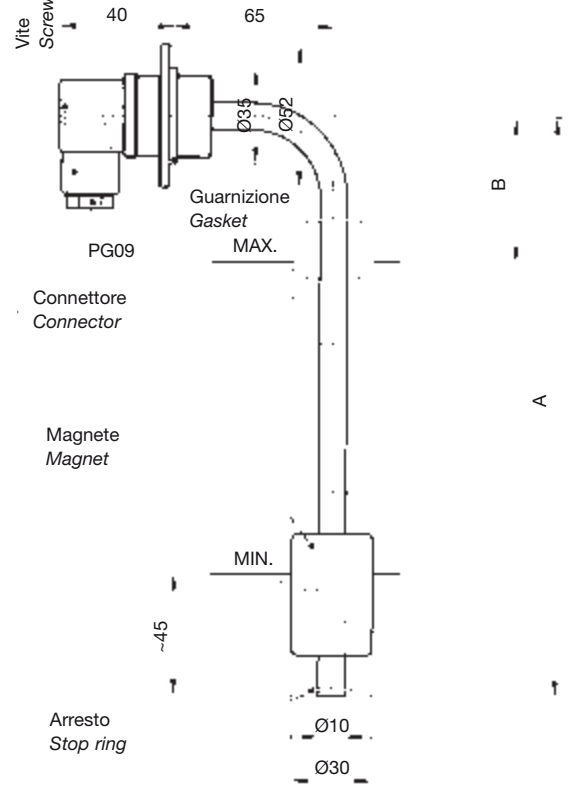

Collegamenti elettrici standard
Standard electrical connection

LMA1FA

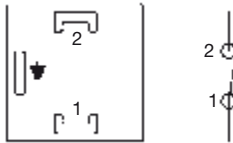

LMA2FA

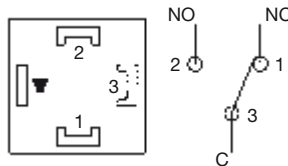

LMMA1FA

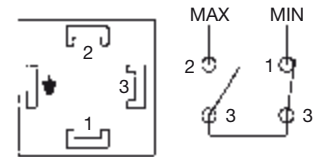

MATERIALI: flangia in alluminio anodizzato, tubo in ottone, anelli di arresto in bronzo, galleggiante in resina espansa NBR.

IMPIEGO E DATI TECNICI (vedere pag. 4 - 5 - 6 - 7).

N.B. - A richiesta, forniamo lunghezze superiori, fino a 1500 mm, oppure diverse da quelle indicate in tabella.

MATERIAL: flange in anodized aluminium, brass stem, stop ring in bronze, NBR float.

APPLICATION AND SPECIFICATIONS (see pages 4 - 5 - 6 - 7).

N.B. - Customized lengths can be supplied on request. Max length 1500 mm.

LMA1FA...		LMA2FA...		LMMA1FA...B...		
TIPO Model	A	TIPO Model	A	TIPO Model	A	B
LMA1FA150	150	LMA2FA150	150	LMMA1FA150B60	150	60
LMA1FA200	200	LMA2FA200	200	LMMA1FA200B70	200	70
LMA1FA250	250	LMA2FA250	250	LMMA1FA250B70	250	70
LMA1FA300	300	LMA2FA300	300	LMMA1FA300B70	300	70
LMA1FA350	350	LMA2FA350	350	LMMA1FA350B70	350	70
LMA1FA400	400	LMA2FA400	400	LMMA1FA400B70	400	70
LMA1FA450	450	LMA2FA450	450	LMMA1FA450B80	450	80
LMA1FA500	500	LMA2FA500	500	LMMA1FA500B80	500	80

LIVELLOSTATI ELETTROMAGNETICI

Float level switches

LM1CSA... LM2CSA...

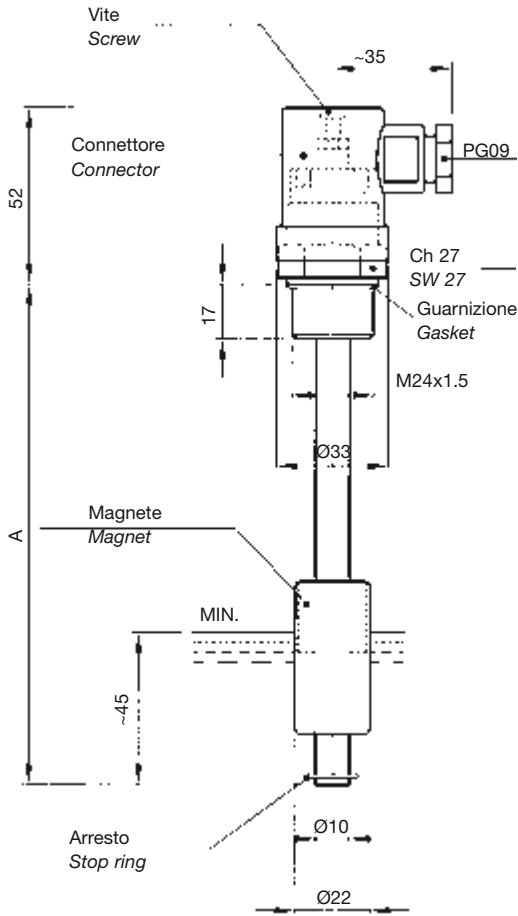

Schema di applicazione
Application chart

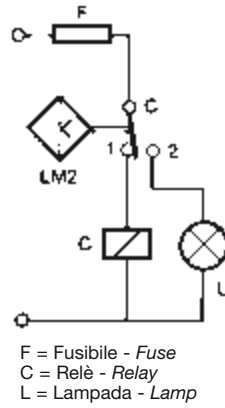

Collegamenti elettrici standard
Standard electrical connection

LM1CSA

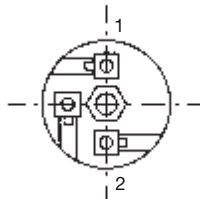

LM2CSA

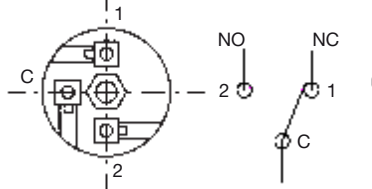

LMM1CSA

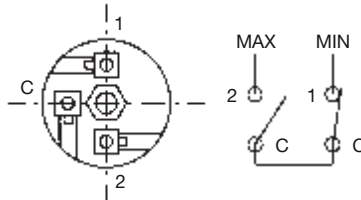

LMM1CSA...B...

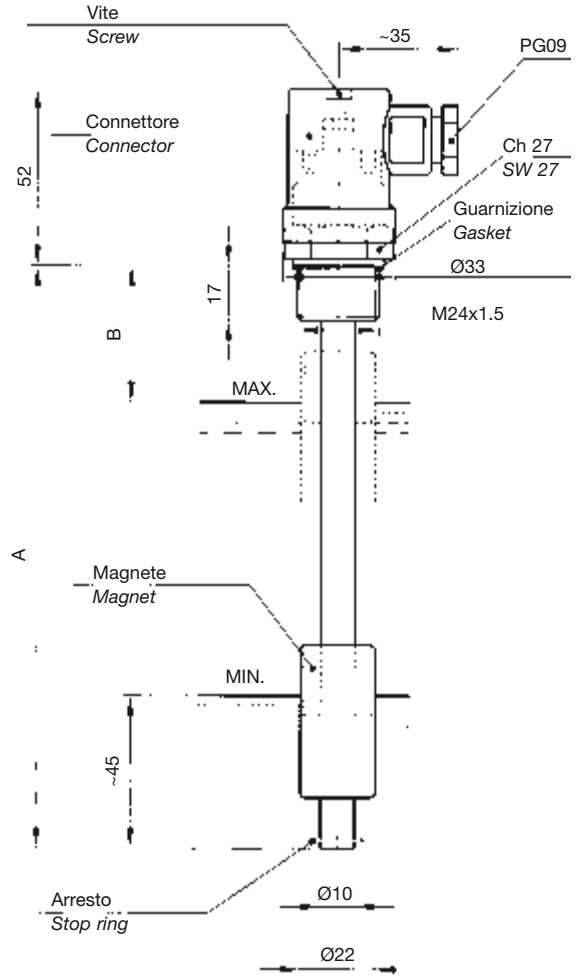

MATERIALI: flangia filettata in alluminio anodizzato, tubo in ottone, anelli di arresto in bronzo, galleggiante in resina espansa NBR.

IMPIEGO E DATI TECNICI
(vedere pag. 4 - 5 - 6 - 7).

N.B. - A richiesta, forniamo lunghezze superiori, fino a 1500 mm, oppure diverse da quelle indicate in tabella.

MATERIAL: thread connection in anodized aluminium, brass stem, stop rings in bronze, NBR float.

APPLICATION AND SPECIFICATIONS
(see pages 4 - 5 - 6 - 7).

N.B. - Customized lengths can be supplied on request. Max length 1500 mm.

LM1CSA...		LM2CSA...		LMM1CSA...B...		
TIPO Model	A	TIPO Model	A	TIPO Model	A	B
LM1CSA150	150	LM2CSA150	150	LMM1CSA150B40	150	40
LM1CSA200	200	LM2CSA200	200	LMM1CSA200B60	200	60
LM1CSA250	250	LM2CSA250	250	LMM1CSA250B60	250	60
LM1CSA300	300	LM2CSA300	300	LMM1CSA300B60	300	60
LM1CSA350	350	LM2CSA350	350	LMM1CSA350B60	350	60
LM1CSA400	400	LM2CSA400	400	LMM1CSA400B70	400	70
LM1CSA450	450	LM2CSA450	450	LMM1CSA450B70	450	70
LM1CSA500	500	LM2CSA500	500	LMM1CSA500B80	500	80

LIVELLOSTATI ELETTROMAGNETICI

Float level switches

LM1CA... LM2CA...

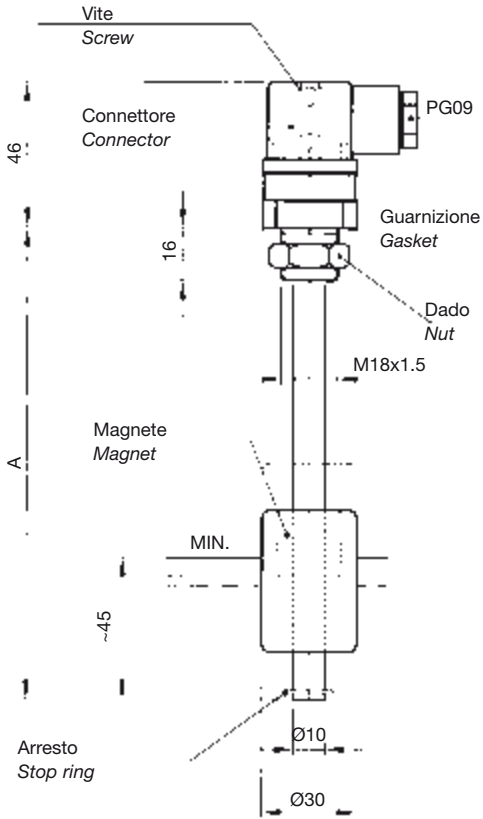

Collegamenti elettrici standard
Standard electrical connection

LM1CA

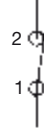
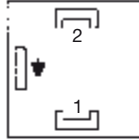

LM2CA

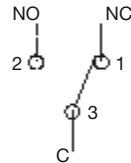
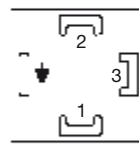

LMM1CA

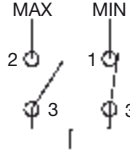
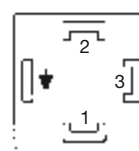

LMM1CA...B...

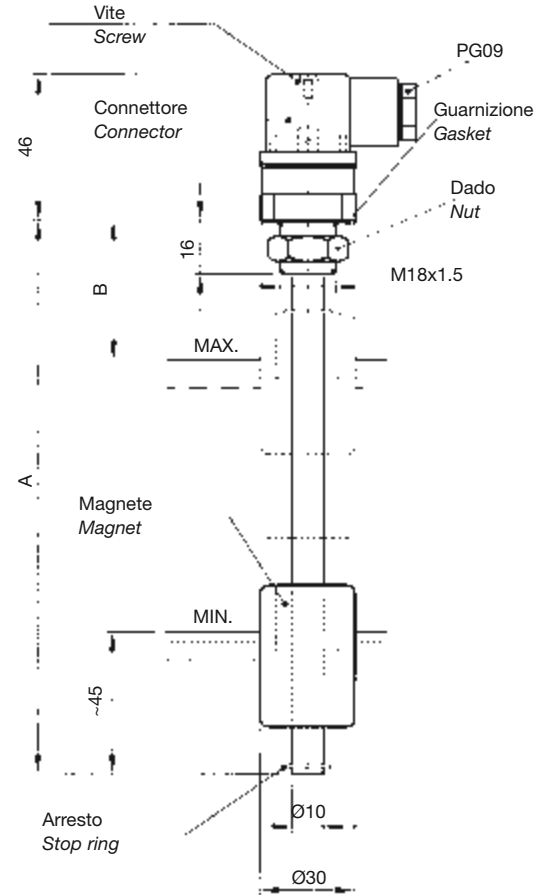

MATERIALI: flangia filettata in alluminio anodizzato, tubo in ottone, anelli di arresto in bronzo, galleggianti in resina espansa NBR.

IMPIEGO E DATI TECNICI
(vedere pag. 4 - 5 - 6 - 7).

N.B. - A richiesta, forniamo lunghezze superiori, fino a 1500 mm, oppure diverse da quelle indicate in tabella.

MATERIAL: thread connection in anodized aluminium, brass stem, stop rings in bronze, NBR float.

APPLICATION AND SPECIFICATIONS
(see pages 4 - 5 - 6 - 7).

N.B. - Customized lengths can be supplied on request. Max. length 1500 mm.

LM1CA...		LM2CA...		LMM1CA...B...		
TIPO Model	A	TIPO Model	A	TIPO Model	A	B
LM1CA100	100	LM2CA100	100			
LM1CA150	150	LM2CA150	150	LMM1CA150B40	150	40
LM1CA200	200	LM2CA200	200	LMM1CA200B60	200	60
LM1CA250	250	LM2CA250	250	LMM1CA250B60	250	60
LM1CA300	300	LM2CA300	300	LMM1CA300B60	300	60
LM1CA350	350	LM2CA350	350	LMM1CA350B60	350	60
LM1CA400	400	LM2CA400	400	LMM1CA400B70	400	70
LM1CA450	450	LM2CA450	450	LMM1CA450B70	450	70
LM1CA500	500	LM2CA500	500	LMM1CA500B80	500	80

LIVELLOSTATI ELETTROMAGNETICI

Float level switches

LM1CFA... LM2CFA...

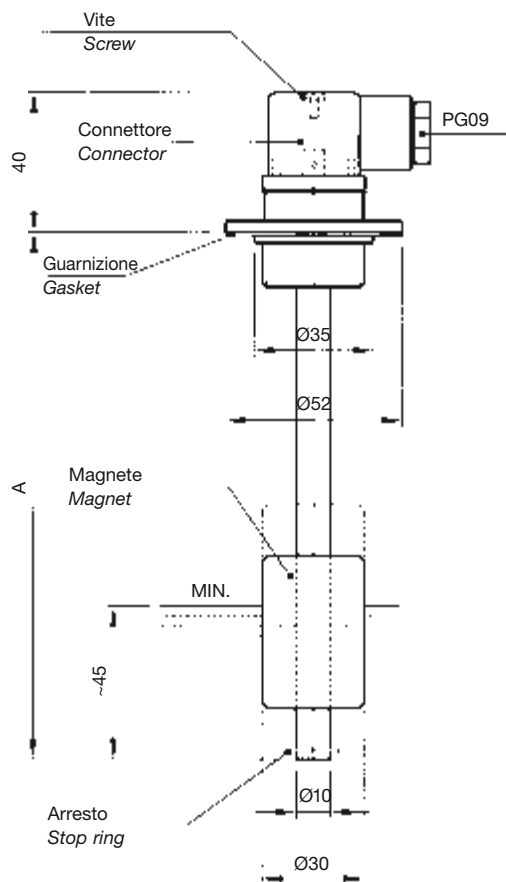

Collegamenti elettrici standard
Standard electrical connection

LM1CFA

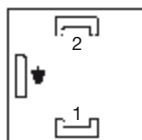

LM2CFA

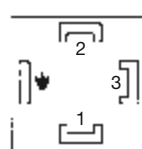

LMM1CFA

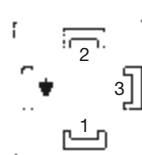

LMM1CFA...B...

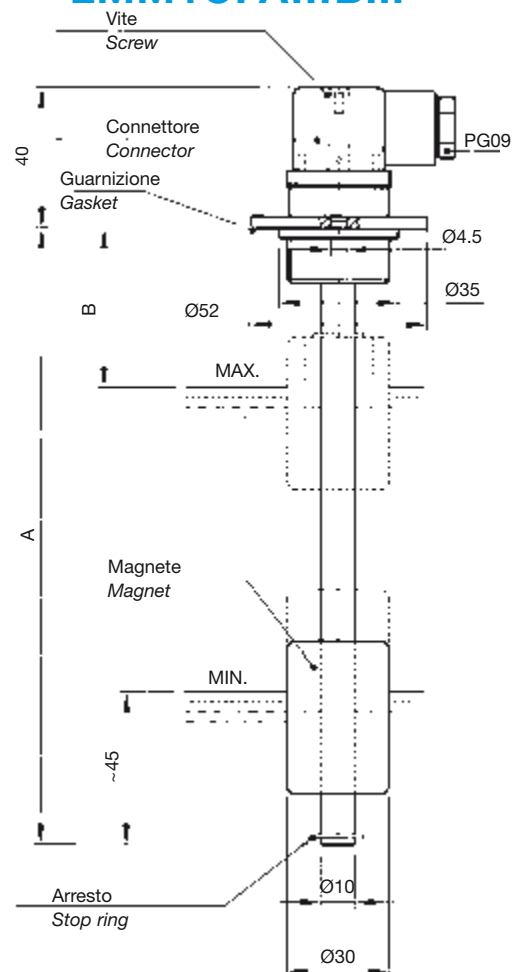

MATERIALI: flangia in alluminio anodizzato, tubo in ottone, anelli di arresto in bronzo, galleggianti in resina espansa NBR.

IMPIEGO E DATI TECNICI
(vedere pag. 4 - 5 - 6 - 7).

N.B. - A richiesta, forniamo lunghezze superiori, fino a 1500 mm, oppure diverse da quelle indicate in tabella.

MATERIAL: flange in anodized aluminium, brass stem, stop rings in bronze, NBR float.

APPLICATION AND SPECIFICATIONS
(see pages 4 - 5 - 6 - 7).

N.B. - Customized lengths can be supplied on request. Max. length 1500 mm.

 Disponibili in versione conforme alla Direttiva ATEX 94/9/CE in esecuzione a sicurezza intrinseca con stringa di certificazione II 1/2 G Ex ia IIB T6.

 Executions also available in accordance with the Directive ATEX 94/9/EC on intrinsic safety equipment with marking II 1/2 G Ex ia IIB T6.

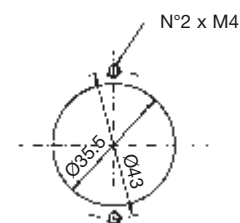

Esempio di foratura
Exemple of perforation

LM1CFA...		LM2CFA...		LMM1CFA...B...		
TIPO Model	A	TIPO Model	A	TIPO Model	A	B
LM1CFA150	150	LM2CFA150	150	LMM1CFA150B40	150	40
LM1CFA200	200	LM2CFA200	200	LMM1CFA200B60	200	60
LM1CFA250	250	LM2CFA250	250	LMM1CFA250B60	250	60
LM1CFA300	300	LM2CFA300	300	LMM1CFA300B60	300	60
LM1CFA350	350	LM2CFA350	350	LMM1CFA350B60	350	60
LM1CFA400	400	LM2CFA400	400	LMM1CFA400B70	400	70
LM1CFA450	450	LM2CFA450	450	LMM1CFA450B70	450	70
LM1CFA500	500	LM2CFA500	500	LMM1CFA500B80	500	80

LIVELLOSTATI ELETTROMAGNETICI

Float level switches

LM1CFPA... LM2CFPA...

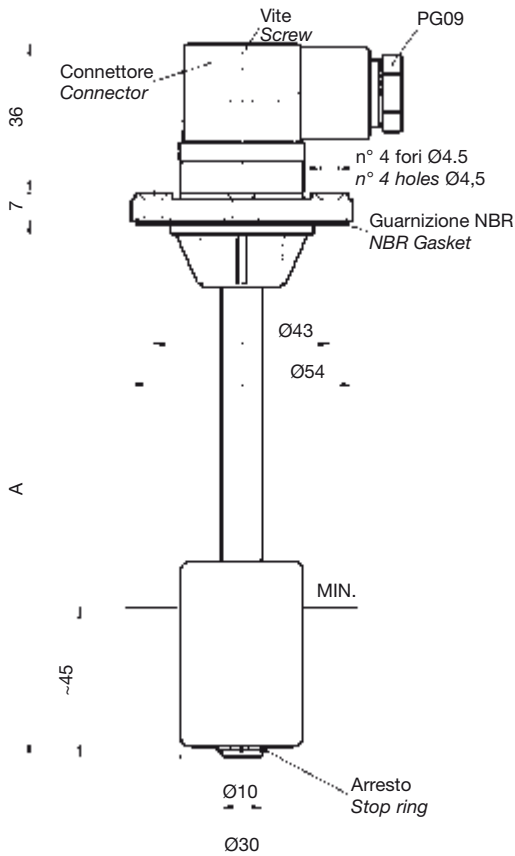

Collegamenti elettrici standard
Standard electrical connection

LM1CFPA

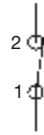
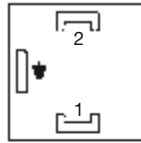

LM2CFPA

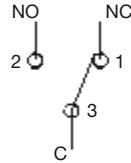
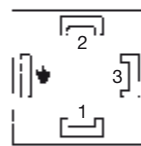

LMM1CFPA

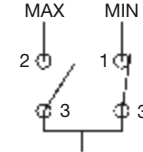
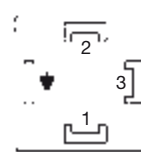

LMM1CFPA... B...

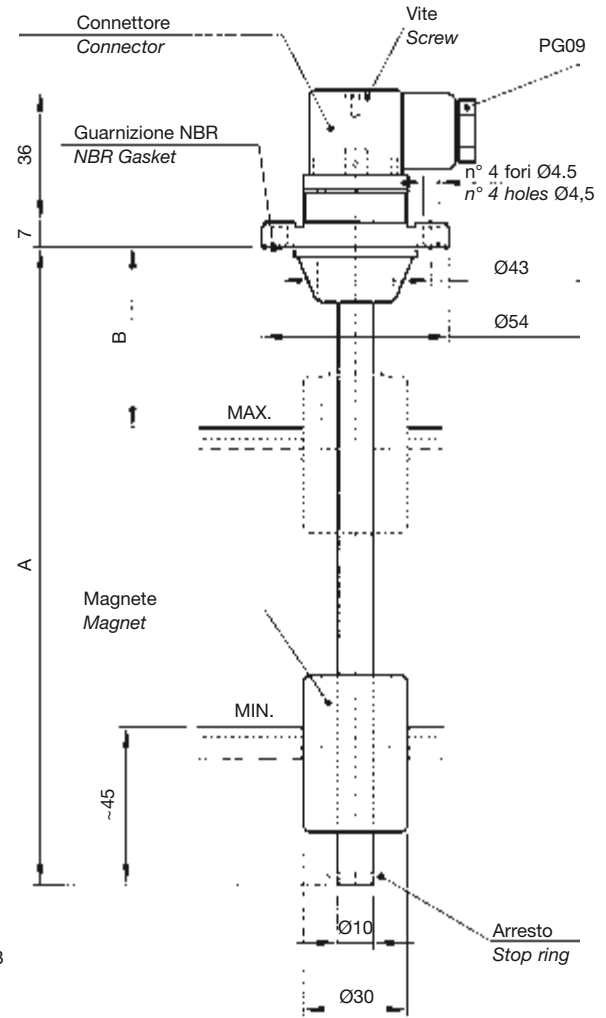

MATERIALI: flangia in termoplastico, tubo in ottone, anelli di arresto in bronzo, galleggiante in resina espansa NBR.

IMPIEGO E DATI TECNICI (vedere pag. 4 - 5 - 6 - 7).

N.B. - A richiesta, forniamo lunghezze superiori, fino a 1500 mm, oppure diverse da quelle indicate in tabella.

 Disponibili in versione conforme alla Direttiva ATEX 94/9/CE in esecuzione a sicurezza intrinseca con stringa di certificazione II 1/2 G Ex ia IIB T6.

MATERIAL: flange in thermoplastic, brass stem, stop rings in bronze, NBR float.

APPLICATION AND SPECIFICATIONS (see pages 4 - 5 - 6 - 7).

N.B. - Customized lengths can be supplied on request. Max. length 1500 mm.

 Executions also available in accordance with the Directive ATEX 94/9/EC on intrinsic safety equipment with marking II 1/2 G Ex ia IIB T6.

LM1CFPA...		LM2CFPA...		LMM1CFPA...B...		
TIPO Model	A	TIPO Model	A	TIPO Model	A	B
LM1CFPA150	150	LM2CFPA150	150	LMM1CFPA150B40	150	40
LM1CFPA200	200	LM2CFPA200	200	LMM1CFPA200B60	200	60
LM1CFPA250	250	LM2CFPA250	250	LMM1CFPA250B60	250	60
LM1CFPA300	300	LM2CFPA300	300	LMM1CFPA300B60	300	60
LM1CFPA350	350	LM2CFPA350	350	LMM1CFPA350B60	350	60
LM1CFPA400	400	LM2CFPA400	400	LMM1CFPA400B70	400	70
LM1CFPA450	450	LM2CFPA450	450	LMM1CFPA450B70	450	70
LM1CFPA500	500	LM2CFPA500	500	LMM1CFPA500B80	500	80

LIVELLOSTATI ELETTROMAGNETICI

Float level switches

LM1CTPA... LM2CTPA...

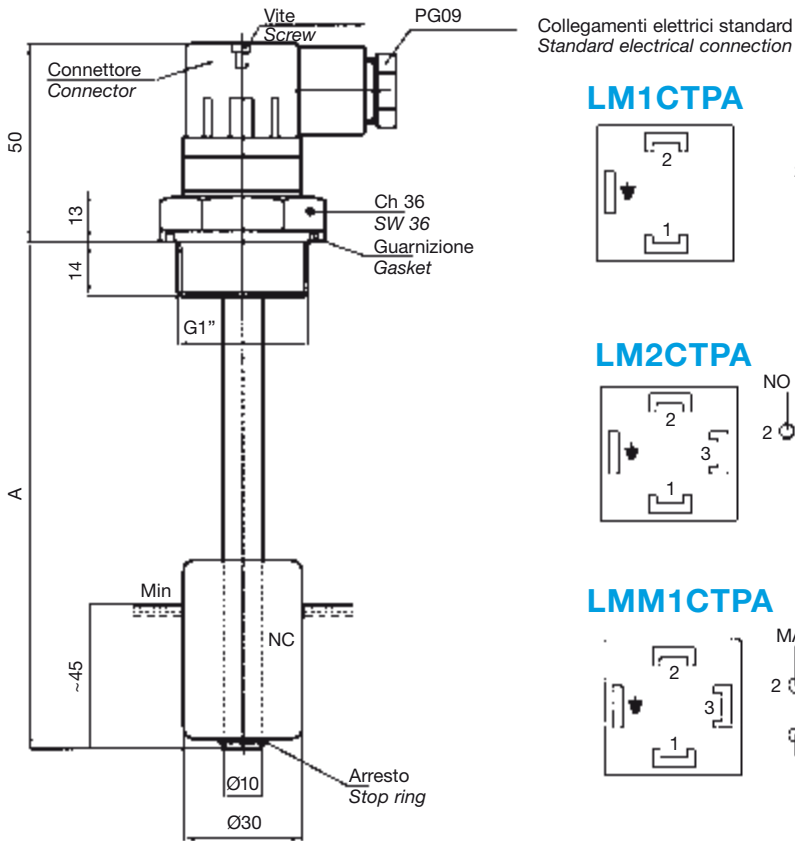

LMM1CTPA...B...

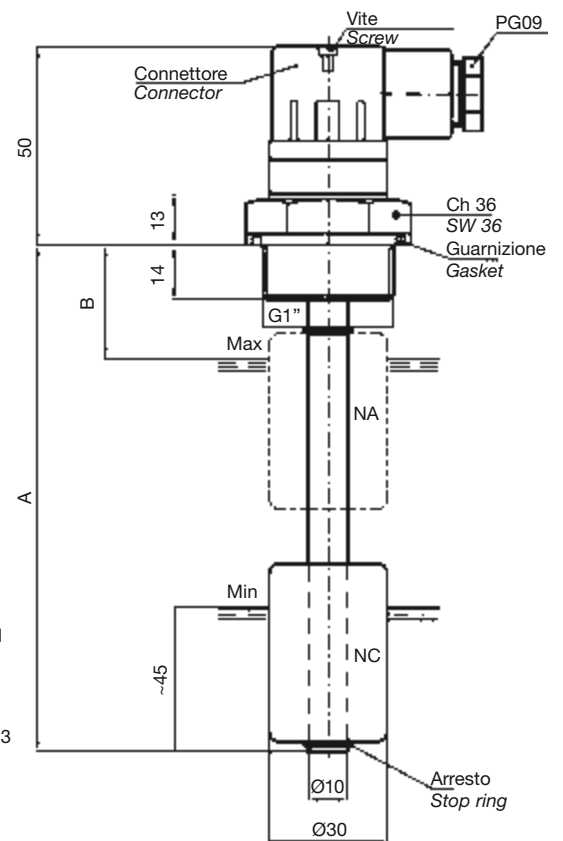

MATERIALI: flangia filettata in termoplastico, tubo in ottone, anelli di arresto in bronzo, galleggiante in resina espansa NBR.

IMPIEGO E DATI TECNICI (vedere pag. 4 - 5 - 6 - 7).

N.B. - A richiesta, forniamo lunghezze superiori, fino a 1500 mm, oppure diverse da quelle indicate in tabella.

 Disponibili in versione conforme alla Direttiva ATEX 94/9/CE in esecuzione a sicurezza intrinseca con stringa di certificazione II 1/2 G Ex ia IIB T6.

MATERIAL: thread connection in thermoplastic, brass stem, stop rings in bronze, NBR float.

APPLICATION AND SPECIFICATIONS (see pages 4 - 5 - 6 - 7).

N.B. - Customized lengths can be supplied on request. Max. length 1500 mm.

 Executions also available in accordance with the Directive ATEX 94/9/EC on intrinsic safety equipment with marking II 1/2 G Ex ia IIB T6.

LM1CTPA...		LM2CTPA...		LMM1CTPA...B...		
TIPO Model	A	TIPO Model	A	TIPO Model	A	B
LM1CTPA150	150	LM2CTPA150	150	LMM1CTPA150B40	150	40
LM1CTPA200	200	LM2CTPA200	200	LMM1CTPA200B60	200	60
LM1CTPA250	250	LM2CTPA250	250	LMM1CTPA250B60	250	60
LM1CTPA300	300	LM2CTPA300	300	LMM1CTPA300B60	300	60
LM1CTPA350	350	LM2CTPA350	350	LMM1CTPA350B60	350	60
LM1CTPA400	400	LM2CTPA400	400	LMM1CTPA400B70	400	70
LM1CTPA450	450	LM2CTPA450	450	LMM1CTPA450B70	450	70
LM1CTPA500	500	LM2CTPA500	500	LMM1CTPA500B80	500	80

LIVELLOSTATI ELETTROMAGNETICI

Float level switches

LM1CTA... LM2CTA...

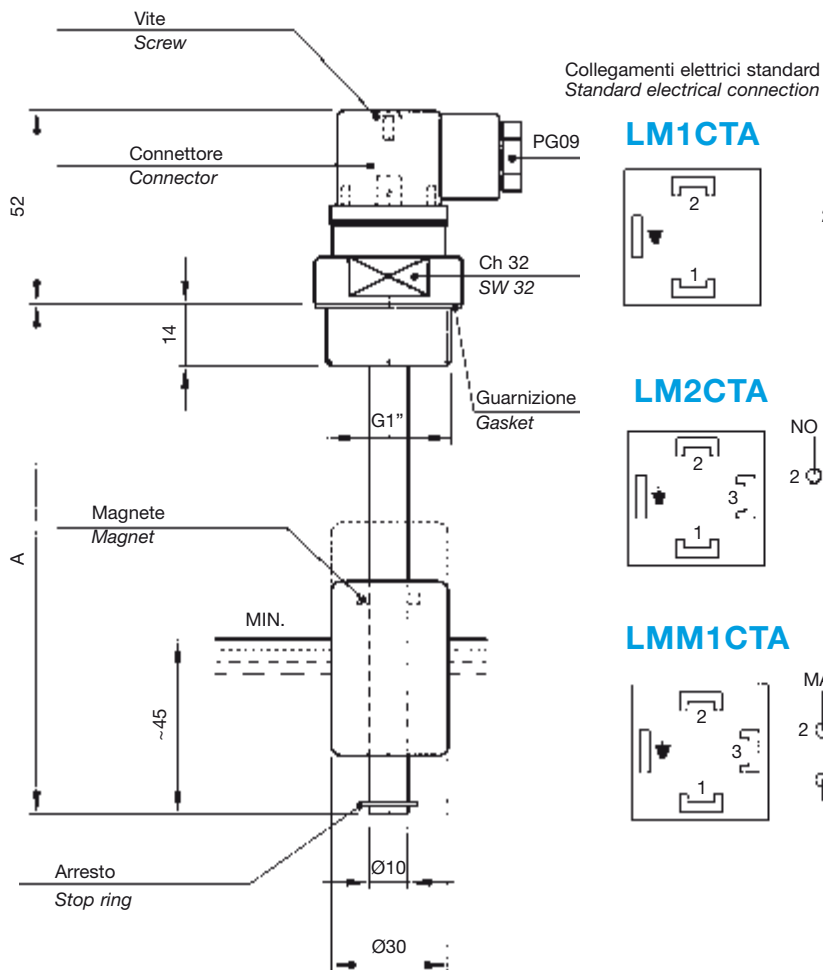

LMM1CTA...B...

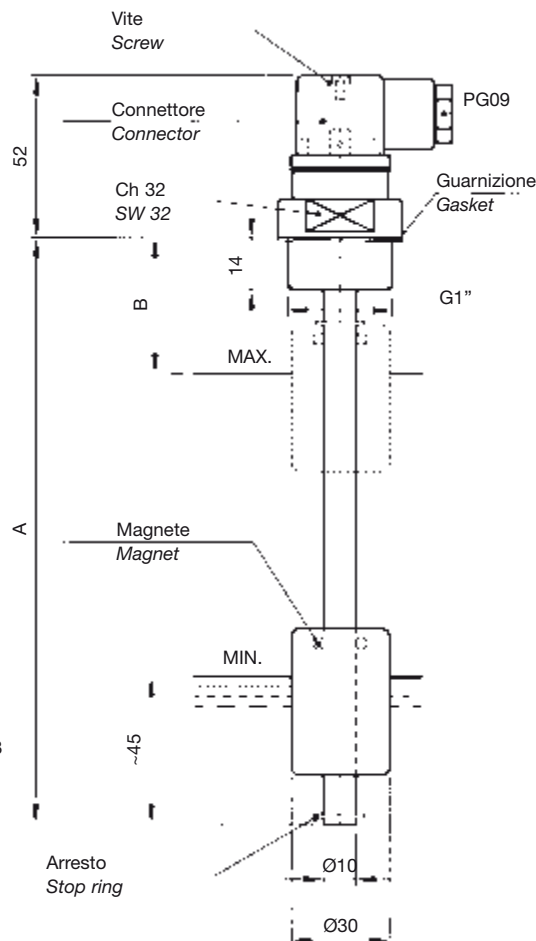

MATERIALI: flangia filettata in alluminio anodizzato, tubo in ottone, anelli di arresto in bronzo, galleggiante in resina espansa NBR.

IMPIEGO E DATI TECNICI (vedere pag. 4 - 5 - 6 - 7).

N.B. - A richiesta, forniamo lunghezze superiori, fino a 1500 mm, oppure diverse da quelle indicate in tabella.

 Disponibili in versione conforme alla Direttiva ATEX 94/9/CE in esecuzione a sicurezza intrinseca con stringa di certificazione II 1/2 G Ex ia IIB T6.

MATERIAL: thread connection in anodized aluminium; brass stem; stop rings in bronze, NBR float.

APPLICATION AND SPECIFICATIONS (see pages 4 - 5 - 6 - 7).

N.B. - Customized lengths can be supplied on request. Max length 1500 mm.

 Executions also available in accordance with the Directive ATEX 94/9/EC on intrinsic safety equipment with marking II 1/2 G Ex ia IIB T6.

LM1CTA...		LM2CTA...		LMM1CTA...B...		
TIPO Model	A	TIPO Model	A	TIPO Model	A	B
LM1CTA150	150	LM2CTA150	150	LMM1CTA150B40	150	40
LM1CTA200	200	LM2CTA200	200	LMM1CTA200B60	200	60
LM1CTA250	250	LM2CTA250	250	LMM1CTA250B60	250	60
LM1CTA300	300	LM2CTA300	300	LMM1CTA300B60	300	60
LM1CTA350	350	LM2CTA350	350	LMM1CTA350B60	350	60
LM1CTA400	400	LM2CTA400	400	LMM1CTA400B70	400	70
LM1CTA450	450	LM2CTA450	450	LMM1CTA450B70	450	70
LM1CTA500	500	LM2CTA500	500	LMM1CTA500B80	500	80

LIVELLOSTATI ELETTROMAGNETICI CON TERMOSTATO FISSO

Float level switches with fixed thermostat

LM1A... T...

LM1FA... T...

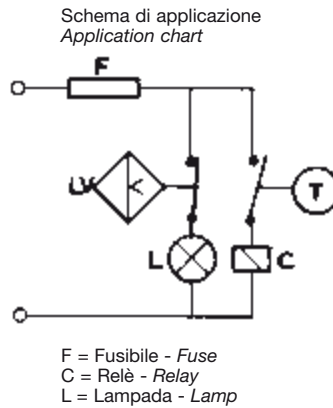
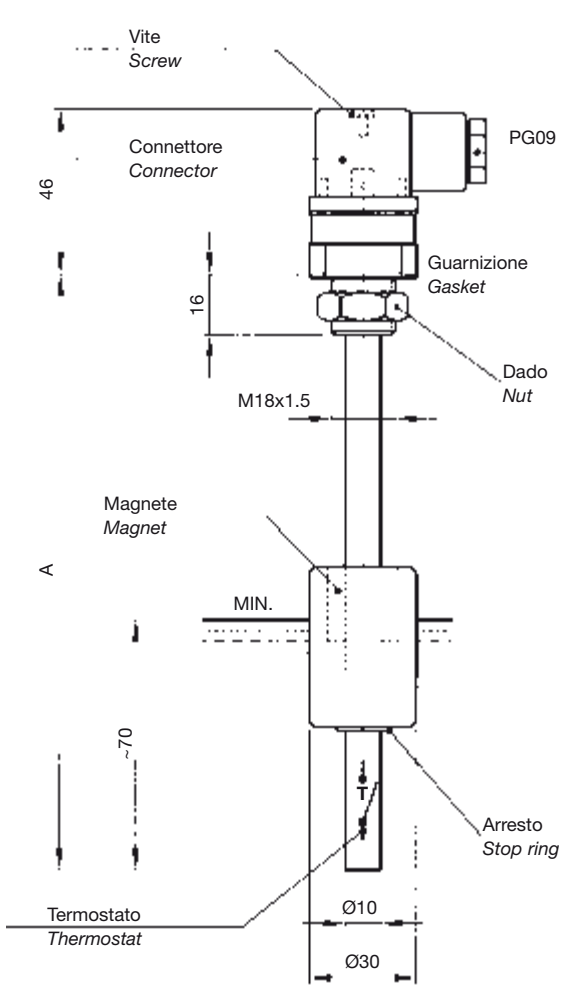

LM1A... T - LM1FA... T

Collegamenti elettrici standard
Standard electrical connection

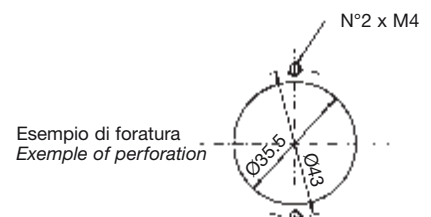
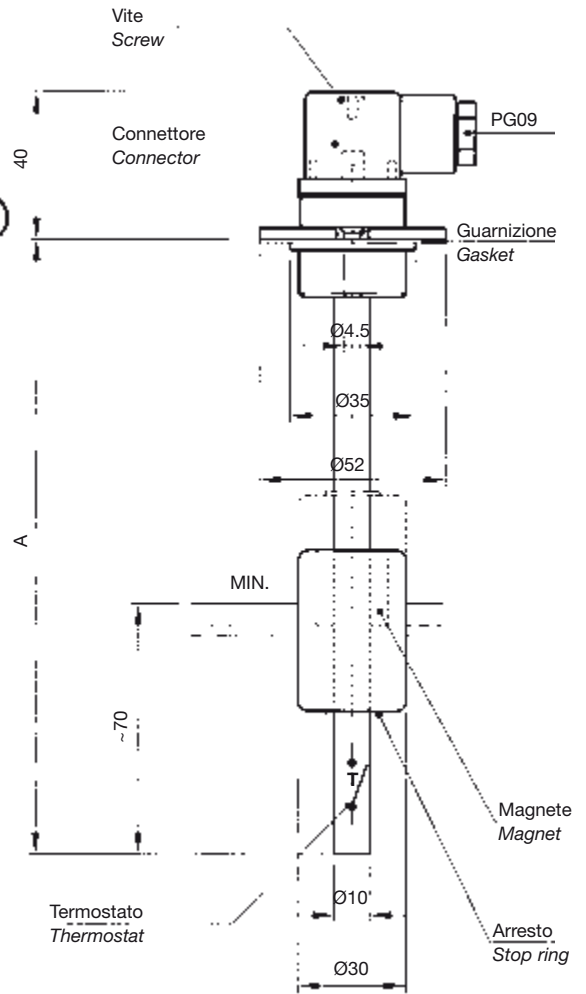
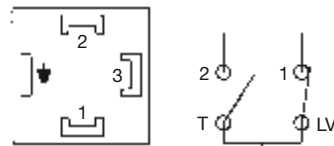

Esempio di ordinazione: LM1A200T50 (50°C)
Ordering example:

MATERIALI: flangia in alluminio anodizzato, tubo in ottone, molla e anelli di arresto in bronzo, galleggiante in resina espansa NBR, termostato bimetallico fisso con contatto NA (V 220/50 Hz - 0,5 A resistivi), differenziale $\Delta T = 7^\circ\text{C}$. Sono disponibili le seguenti temperature: 40° - 50° - 60° - 70° - 80°C.

IMPIEGO E DATI TECNICI (vedere pag. 4 - 5 - 6 - 7).

N.B. - A richiesta, forniamo lunghezze superiori, fino a 1500 mm, oppure diverse da quelle indicate in tabella.

Indicare negli ordini la temperatura desiderata.

MATERIAL: flange in anodized aluminium, brass stem, spring and stop rings in bronze, NBR float, bimetallic fixed thermostat with NO contact (V 220/50 Hz - 0,5 A resistive), differential $T = 7^\circ\text{C}$. Thermostat settings: 40° - 50° - 60° - 70° - 80°C.

APPLICATION AND SPECIFICATIONS (see pages 4 - 5 - 6 - 7).

N.B. - Customized lengths can be supplied on request. Max. length 1500 mm.

When ordering please indicate the temperature required.

LM1A...	LM1FA...	Stem length A Lunghezza	Temperature °C Temperatura °C
LM1A150T...	LM1FA150T...	150	40 50 60 70 80
LM1A200T...	LM1FA200T...	200	
LM1A250T...	LM1FA250T...	250	
LM1A300T...	LM1FA300T...	300	
LM1A350T...	LM1FA350T...	350	
LM1A400T...	LM1FA400T...	400	
LM1A450T...	LM1FA450T...	450	
LM1A500T...	LM1FA500T...	500	

LIVELLOSTATI ELETTROMAGNETICI CON TERMOSTATO FISSO

Float level switches with fixed thermostat

LM1TA... T...

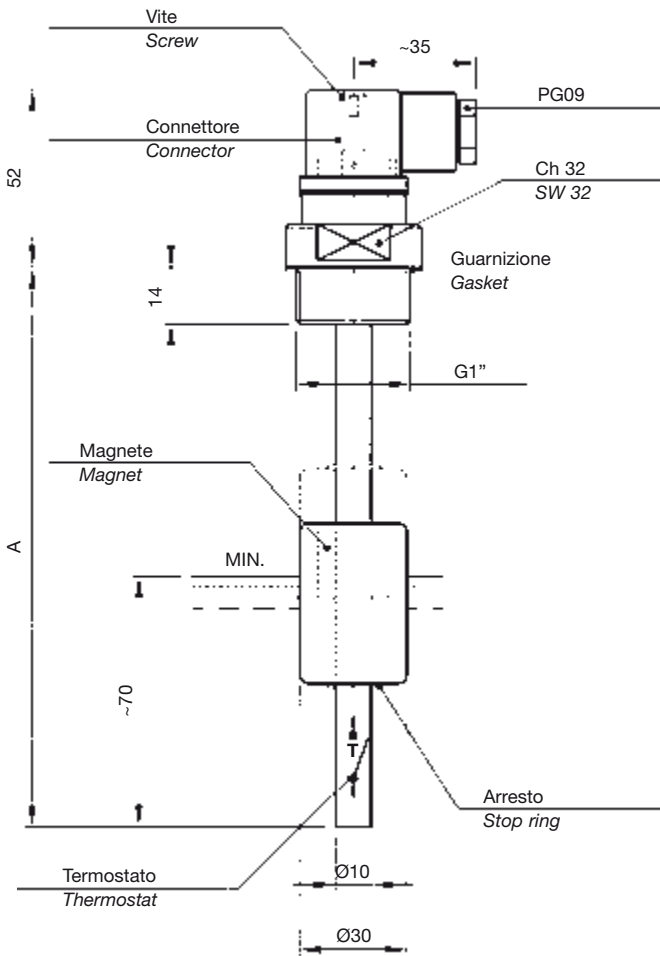

LM1TA... T

Collegamenti elettrici standard
Standard electrical connection

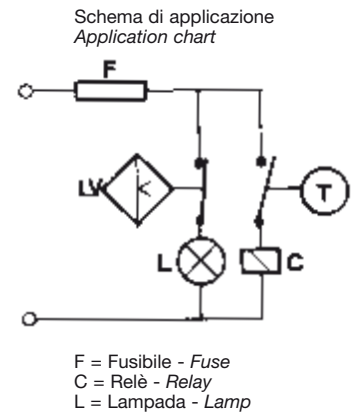
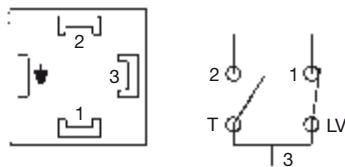

Esempio di ordinazione: LM1TA300T60 (60°C)
Ordering example:

Lunghezze standard
Standard lengths 150 - 200 - 250 - 300 - 350 - 400 - 450 - 500

MATERIALI: flangia filettata in alluminio anodizzato, tubo in ottone, molla e anelli di arresto in bronzo, galleggiante in resina espansa NBR, termostato bimetallico fisso con contatto NA (V 220/50 Hz - 0,5 A resistivi), differenziale $\Delta T = 7^\circ\text{C}$. Sono disponibili le seguenti temperature: 40° - 50° - 60° - 70° - 80°C.

IMPIEGO E DATI TECNICI (vedere pag. 4 - 5 - 6 - 7).

N.B. - A richiesta, forniamo lunghezze superiori, fino a 1500 mm, oppure diverse da quelle indicate.

Indicare negli ordini la temperatura desiderata.

MATERIAL: threaded flange in anodized aluminium, brass stem, spring and stop rings in bronze, NBR float, bimetallic fixed thermostat with NO contact (V 220/50 Hz - 0,5 A resistive), differential $\Delta T = 7^\circ\text{C}$. Thermostat settings: 40° - 50° - 60° - 70° - 80°C.

APPLICATION AND SPECIFICATIONS (see pages 4 - 5 - 6 - 7).

N.B. - Customized lengths can be supplied on request. Max. length 1500 mm.

When ordering please indicate the temperature required.

LIVELLOSTATI ELETTROMAGNETICI - INOX

Float level switches - Stainless steel

**LM1FIA...
LM2FIA...**

LMM1FIA...B...

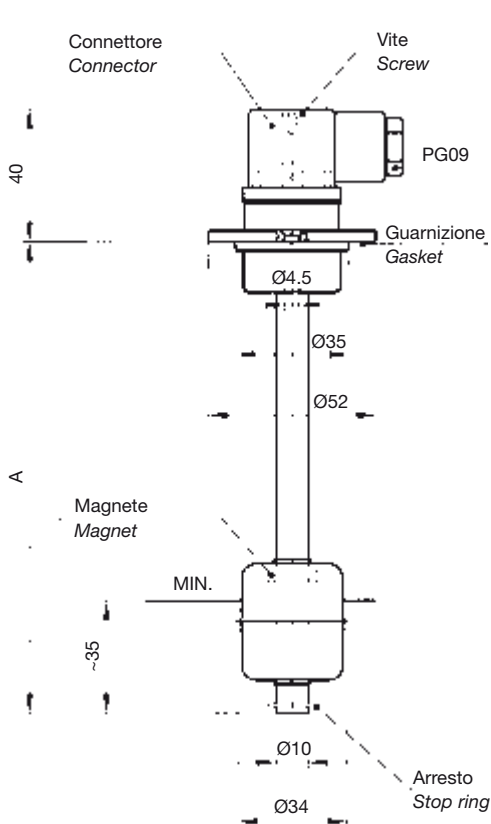

Collegamenti elettrici standard
Standard electrical connection

LM1FIA

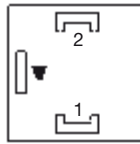

LM2FIA

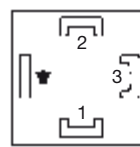

LMM1FIA

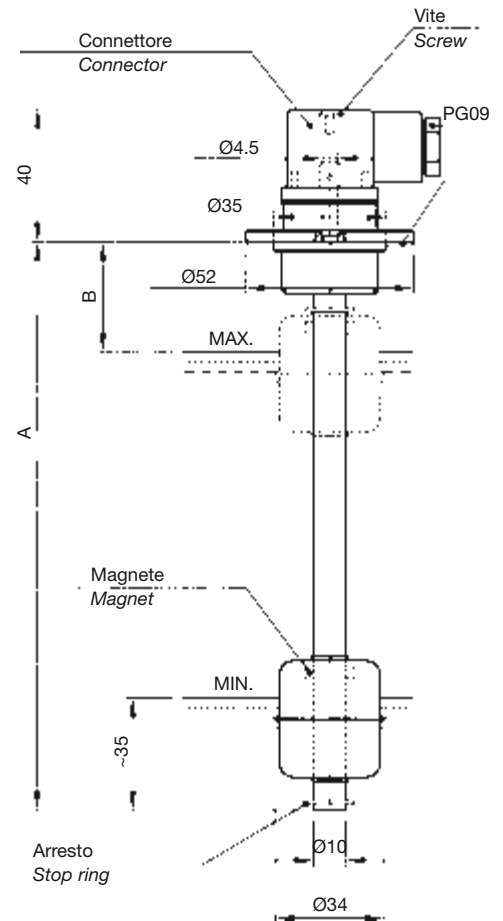
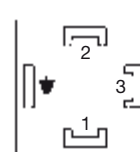

MATERIALE: flangia, tubo, anelli di arresto e galleggiante in acciaio inox.

IMPIEGO E DATI TECNICI (vedere pag. 4 - 5 - 6 - 7).

N.B. - A richiesta, forniamo lunghezze superiori, fino a 1500 mm, oppure diverse da quelle indicate in tabella.

MATERIAL: flange, stem, stop rings and float in stainless steel.

APPLICATION AND SPECIFICATIONS
(see pages 4 - 5 - 6 - 7).

N.B. - Customized lengths can be supplied on request. Max. length 1500 mm.



Disponibili in versione conforme alla Direttiva ATEX 94/9/CE in esecuzione a sicurezza intrinseca con stringa di certificazione II 1/2 G Ex ia IIC T6.



Executions also available in accordance with the Directive ATEX 94/9/EC on intrinsic safety equipment with marking II 1/2 G Ex ia IIC T6.

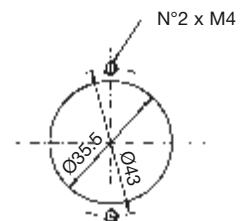

Esempio di foratura
Exemple of perforation

LM1FIA...		LM2FIA...		LMM1FIA...B...		
TIPO Model	A	TIPO Model	A	TIPO Model	A	B
LM1FIA150	150	LM2FIA150	150	LMM1FIA150B50	150	50
LM1FIA200	200	LM2FIA200	200	LMM1FIA200B60	200	60
LM1FIA250	250	LM2FIA250	250	LMM1FIA250B60	250	60
LM1FIA300	300	LM2FIA300	300	LMM1FIA300B60	300	60
LM1FIA350	350	LM2FIA350	350	LMM1FIA350B60	350	60
LM1FIA400	400	LM2FIA400	400	LMM1FIA400B70	400	70
LM1FIA450	450	LM2FIA450	450	LMM1FIA450B70	450	70
LM1FIA500	500	LM2FIA500	500	LMM1FIA500B80	500	80

LIVELLOSTATI ELETTROMAGNETICI - INOX

Float level switches - Stainless steel

LMA1FIA... LMA2FIA...

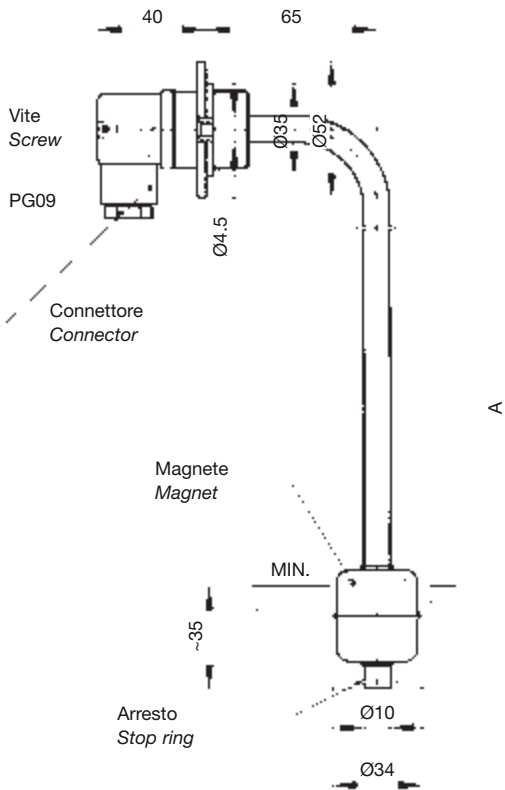

Esempio di foratura
Exemple of perforation

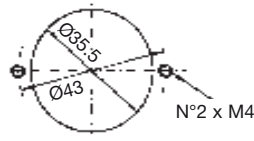

LMMA1FIA...B...

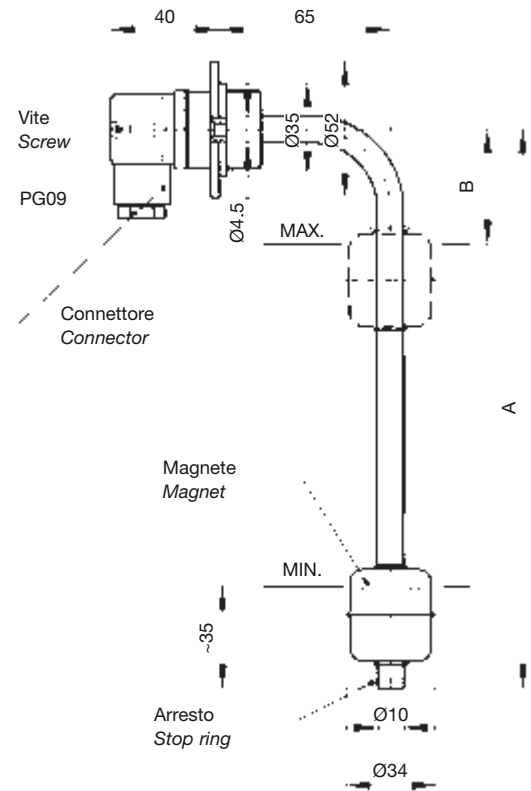

Collegamenti elettrici standard
Standard electrical connection

LMA1FIA

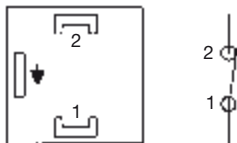

LMA2FIA

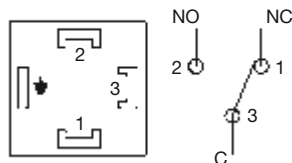

LMMA1FIA

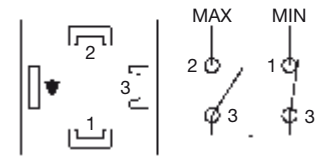

MATERIALI: flangia, tubo, anelli di arresto e galleggiante in acciaio inox.

IMPIEGO E DATI TECNICI (vedere pag. 4 - 5 - 6 - 7).

N.B. - A richiesta, forniamo lunghezze superiori, fino a 1500 mm, oppure diverse da quelle indicate in tabella.

MATERIAL: flange, stem, stop rings and float in stainless steel.

APPLICATION AND SPECIFICATIONS (see pages 4 - 5 - 6 - 7).

N.B. - Customized lengths can be supplied on request. Max length 1500 mm.

LMA1FIA...		LMA2FIA...		LMMA1FIA...B...		
TIPO Model	A	TIPO Model	A	TIPO Model	A	B
LMA1FIA150	150	LMA2FIA150	150	LMMA1FIA150B60	150	60
LMA1FIA200	200	LMA2FIA200	200	LMMA1FIA200B70	200	70
LMA1FIA250	250	LMA2FIA250	250	LMMA1FIA250B70	250	70
LMA1FIA300	300	LMA2FIA300	300	LMMA1FIA300B70	300	70
LMA1FIA350	350	LMA2FIA350	350	LMMA1FIA350B70	350	70
LMA1FIA400	400	LMA2FIA400	400	LMMA1FIA400B70	400	70
LMA1FIA450	450	LMA2FIA450	450	LMMA1FIA450B80	450	80
LMA1FIA500	500	LMA2FIA500	500	LMMA1FIA500B80	500	80

LIVELLOSTATI ELETTROMAGNETICI - INOX

Float level switches - Stainless steel

LM1TIA... LM2TIA...

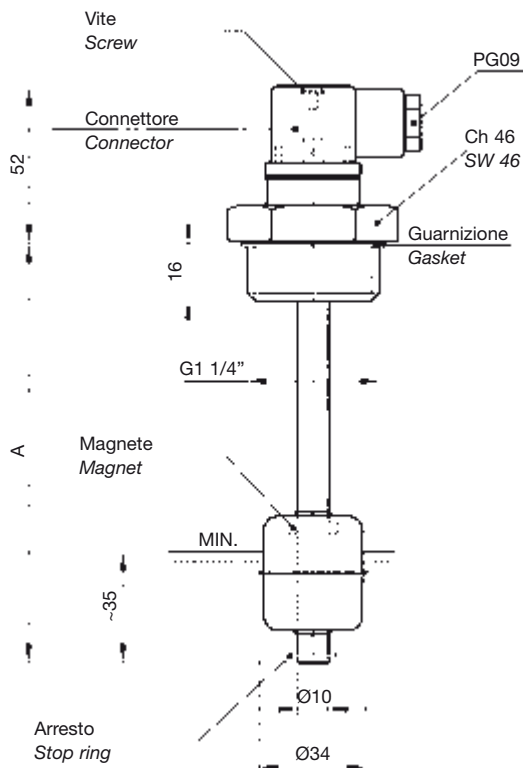

Collegamenti elettrici standard
Standard electrical connection

LM1TIA

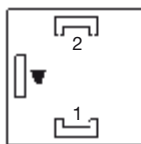

LM2TIA

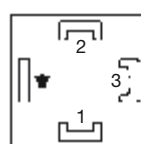

LMM1TIA

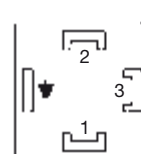

LMM1TIA...B...

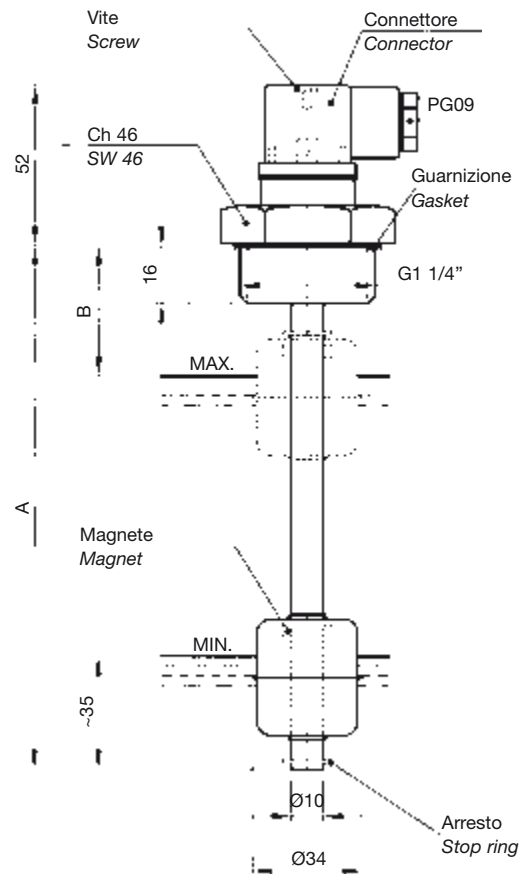

MATERIALE: flangia filettata G 1 1/4", tubo, anelli di arresto e galleggiante in acciaio inox.

IMPIEGO E DATI TECNICI (vedere pag. 4 - 5 - 6 - 7).

N.B. - A richiesta, forniamo lunghezze superiori, fino a 1500 mm, oppure diverse da quelle indicate in tabella.

 Disponibili in versione conforme alla Direttiva ATEX 94/9/CE in esecuzione a sicurezza intrinseca con stringa di certificazione II 1/2 G Ex ia IIC T6.

MATERIAL: G1 1/4" threaded flange, stem, stop rings and float in stainless steel.

APPLICATION AND SPECIFICATIONS (see pages 4 - 5 - 6 - 7).

N.B. - Customized lengths can be supplied on request. Max. length 1500 mm.

 Executions also available in accordance with the Directive ATEX 94/9/EC on intrinsic safety equipment with marking II 1/2 G Ex ia IIC T6.

LM1TIA...		LM2TIA...		LMM1TIA...B...		
TIPO Model	A	TIPO Model	A	TIPO Model	A	B
LM1TIA150	150	LM2TIA150	150	LMM1TIA150B50	150	50
LM1TIA200	200	LM2TIA200	200	LMM1TIA200B60	200	60
LM1TIA250	250	LM2TIA250	250	LMM1TIA250B60	250	60
LM1TIA300	300	LM2TIA300	300	LMM1TIA300B60	300	60
LM1TIA350	350	LM2TIA350	350	LMM1TIA350B60	350	60
LM1TIA400	400	LM2TIA400	400	LMM1TIA400B70	400	70
LM1TIA450	450	LM2TIA450	450	LMM1TIA450B70	450	70
LM1TIA500	500	LM2TIA500	500	LMM1TIA500B80	500	80

LIVELLOSTATI ELETTROMAGNETICI - INOX

Float level switches - Stainless steel

LM1PTIA... LM2PTIA...

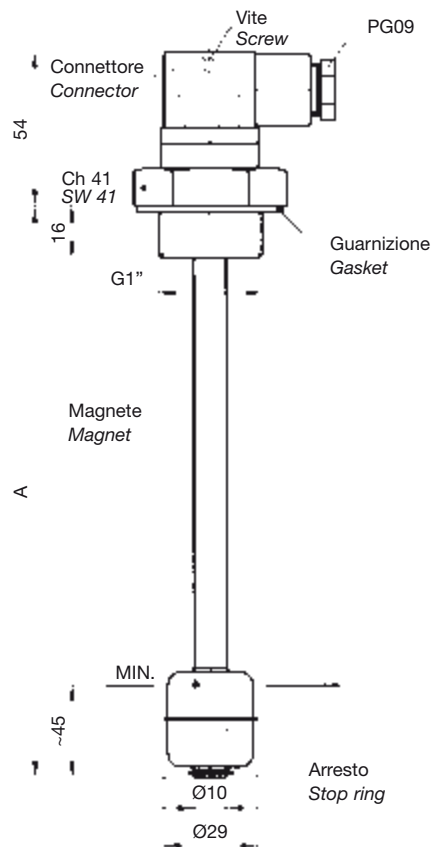

Collegamenti elettrici standard
Standard electrical connection

LM1PTIA

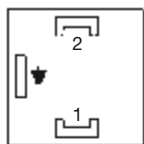

LM2PTIA

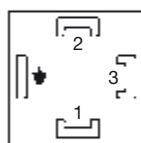

LMM1PTIA

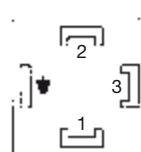

LMM1PTIA...B...

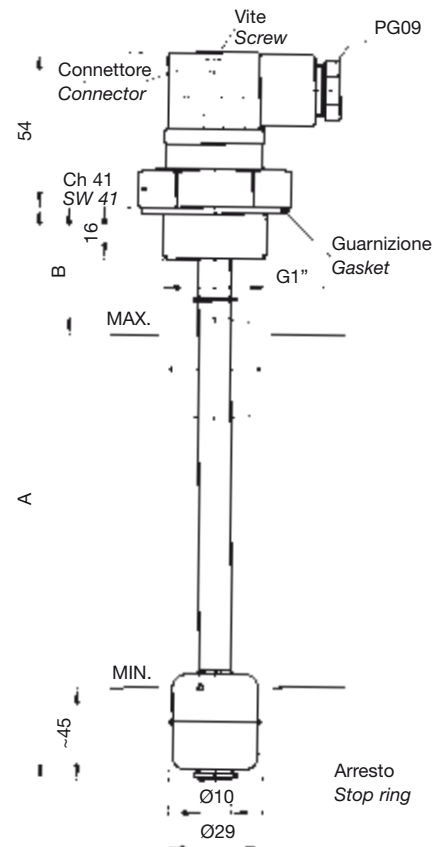

IMPIEGO

Sono stati studiati per controllare il minimo o il massimo livello di olio, acqua, solventi, in un serbatoio e inviare a distanza un segnale elettrico. Devono essere montati verticalmente sul coperchio del serbatoio in modo che il galleggiante disti almeno 50 mm. dalle pareti metalliche.

DATI TECNICI

Potenza commutabile in CC	60 W
Potenza commutabile in CA	60 VA
Intensità di corrente	0,8 A (resistivi)
Tensione max. di lavoro	220 V - 50 Hz
Tensione di breakdown	300 V
Capacità dei contatti aperti	0,6 pF
Resistenza d'isolamento	10 ¹⁰ Ohm min.
Contatto a riposo (senza fluido)	NC

CON CONTATTI SPDT

Potenza commutabile	30 W
Corrente commutabile	0,5 A (resistivi)
Resistenza d'isolamento	10 ⁹ OHM min.
Capacità dei contatti	2 pF
Campo di temperatura	-10 +80°C
Peso specifico liquido	≥ 0,8
Pressione massima	8 Bar
Viscosità del fluido	max 150 cSt
Materiale	Acciaio inox AISI 316

PER CARICHI INDUTTIVI IMPIEGARE CIRCUITO DI PROTEZIONE.

USE

This series of electromagnetic level switches has been designed to check the minimum or maximum level of oil, water, solvents in a tank and send an electric signal to a remote board in case the fluid goes over or under the set levels. They should be fixed vertically on the cover of the tank, with the float at least 50 mm far from metal walls.

SPECIFICATIONS

Switching capacity in DC	60 W
Switching capacity in AC	60 VA
Current	0.8 A (resistive)
Voltage	220 V - 50 Hz
Breakdown voltage	300 V
Capacitance	0,6 pF
Insulation resistance	10 ¹⁰ Ohm
Contact (dry condition)	NC

WITH SPDT CONTACTS

Switching capacity	30 W
Current	0.5 A (resistive)
Insulation resistance	10 ⁹ Ohm min.
Switching capacity	2 pf
Temperature range	-10 +80°C
Fluid specific weight	≥ 0,8
Maximum pressure	8 Bar
Fluid viscosity	max 150 cSt
Material	Stainless steel AISI 316

WITH INDUCTIVE LOADS A PROTECTION CIRCUIT IS TO BE USED.

LIVELLOSTATI ELETTROMAGNETICI

Float level switches

LM1GSA... LM2GSA...

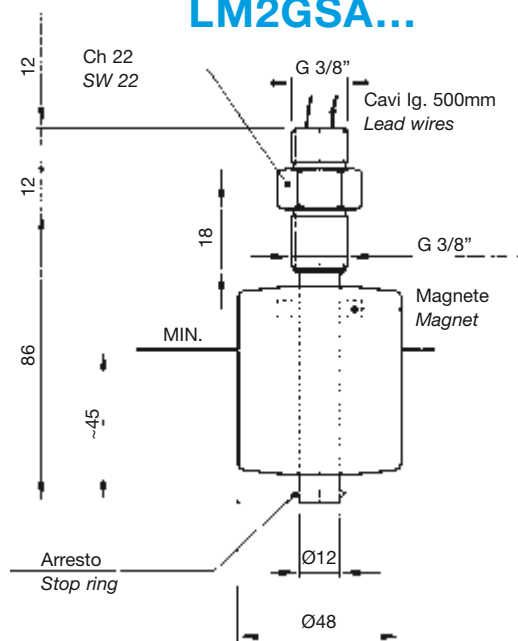

Schema di applicazione Application chart

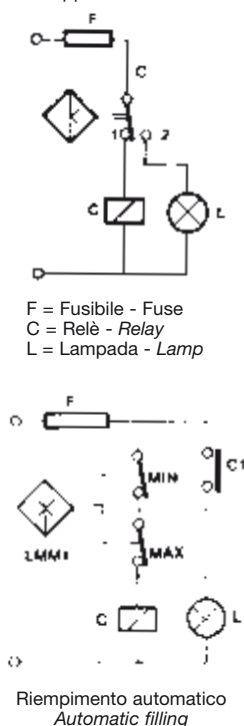

Riempimento automatico Automatic filling

LMM1GSA...B...

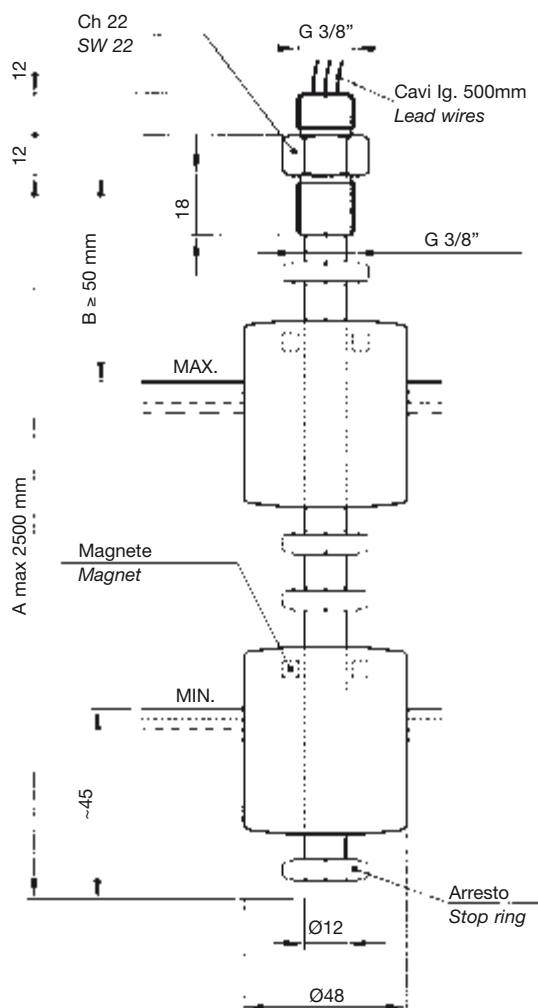

N.B. - Negli ordini indicare le quote A e B.
N.B. - When ordering indicate A and B references

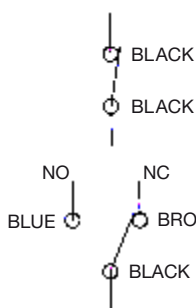

LM1GSA NC CONTACT

LM2GSA SPDT CONTACT

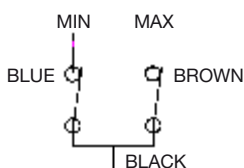

LMM1GSA MIN - MAX CONTACTS

IMPIEGO

Sono stati studiati per controllare il minimo o il massimo livello di un fluido contenuto in un serbatoio e per inviare un segnale elettrico di allarme a distanza. Devono essere montati verticalmente sul coperchio del serbatoio in modo che il galleggiante disti almeno 50 mm. dalle pareti metalliche.

DATI TECNICI

Potenza commutabile in CC	60 W
Potenza commutabile in CA	60 VA
Intensità di corrente	0.8 A (resistivi)
Tensione max. di lavoro	~220 V - 50 Hz
Tensione di breakdown	300 V
Capacità dei contatti aperti	0,6 pF
Contatti a riposo (senza fluido)	NC
Resistenza d'isolamento	10 ¹⁰ Ohm

CON CONTATTI SPDT (SC)

Potenza commutabile	30 W
Corrente commutabile in CC	0,5 A (resistivi)
Resistenza d'isolamento	10 ⁹ Ohm min.
Capacità dei contatti	2 pF

Peso specifico del liquido	≥0,7
Pressione massima	10 Bar
Viscosità del fluido	max 150 cSt
Campo di temperatura	-10 +80°C
Materiali	Corpo ottone, galleggiante in NBR

PER CARICHI INDUTTIVI IMPIEGARE CIRCUITO DI PROTEZIONE.

USE

This series of electromagnetic level switches has been designed to check the minimum or maximum level of a fluid in a tank and send an electric signal to a remote board in case the fluid goes over or under the set levels. They should be fixed vertically on the cover of the tank, with the float at least 50 mm far from metal walls.

SPECIFICATIONS

Switching capacity in DC	60 W
Switching capacity in AC	60 VA
Current	0.8 A (resistive)
Voltage	~220 V - 50 Hz
Breakdown voltage	300 V
Capacitance	0,6 pF
Contact (dry condition)	NC
Insulation resistance	10 ¹⁰ Ohm

WITH SPDT CONTACTS (SC)

Switching capacity	30 W
Current	0.5 A (resistive)
Insulation resistance	10 ⁹ Ohm min.
Capacitance	2 pF

Fluid specific gravity	≥0.7
Maximum pressure	10 Bar
Fluid viscosity	max 150 cSt
Temperature range	-10 +80°C
Material	Brass body - NBR float

WITH INDUCTIVE LOADS A PROTECTION CIRCUIT IS TO BE USED.

LIVELLOSTATI ELETTROMAGNETICI

Float level switches

LM3 GSA... B... C...

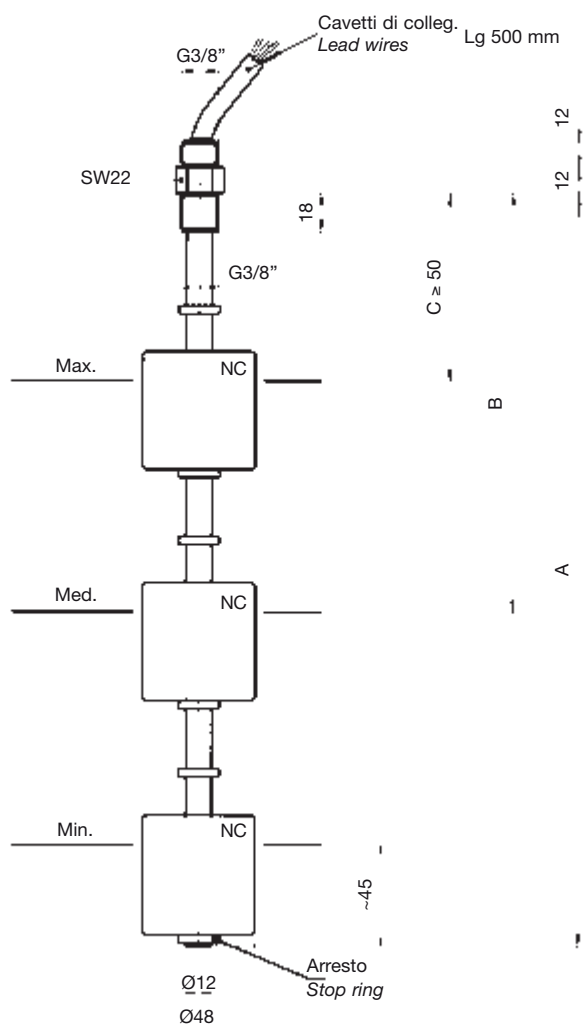

N.B. - Negli ordini, a seconda del modello, indicare le quote A - B - C - D.
 Min. distanza fra i contatti B - C - D = 90 mm.
 Esempio di ordinazione: LM3GSA600B300C50
 Su richiesta, sono disponibili versioni con contatti NA o SPDT.

IMPIEGO

Sono stati studiati per controllare il livello di un fluido contenuto in un serbatoio e per inviare un segnale elettrico di allarme a distanza. Devono essere montati verticalmente sul coperchio del serbatoio in modo che il galleggiante disti almeno 50 mm. dalle pareti metalliche.

DATI TECNICI

Lunghezza asta max	A = 2500 mm
Potenza commutabile in CC	60 W
Potenza commutabile in CA	60 VA
Intensità di corrente	0,8 A (resistivi)
Tensione max. di lavoro	~220 V - 50 Hz
Tensione di breakdown	300 V
Capacità dei contatti aperti	0,6 pF
Resistenza d'isolamento	10 ¹⁰ Ohm
Contatti (senza fluido)	NC
CON CONTATTI SPDT "SC"	
Potenza commutabile	30 W
Corrente commutabile in CC	0,5 A (resistivi)
Resistenza d'isolamento	10 ⁹ Ohm min.
Capacità dei contatti	2 pF
Campo di temperatura	-10 +80°C
Peso specifico del liquido	≥0,7
Pressione massima	10 Bar
Viscosità del fluido	max 150 cSt
Materiali	Corpo ottone, galleggiante in NBR

PER CARICHI INDUTTIVI IMPIEGARE CIRCUITO DI PROTEZIONE.

LM4 GSA... B... C... D...

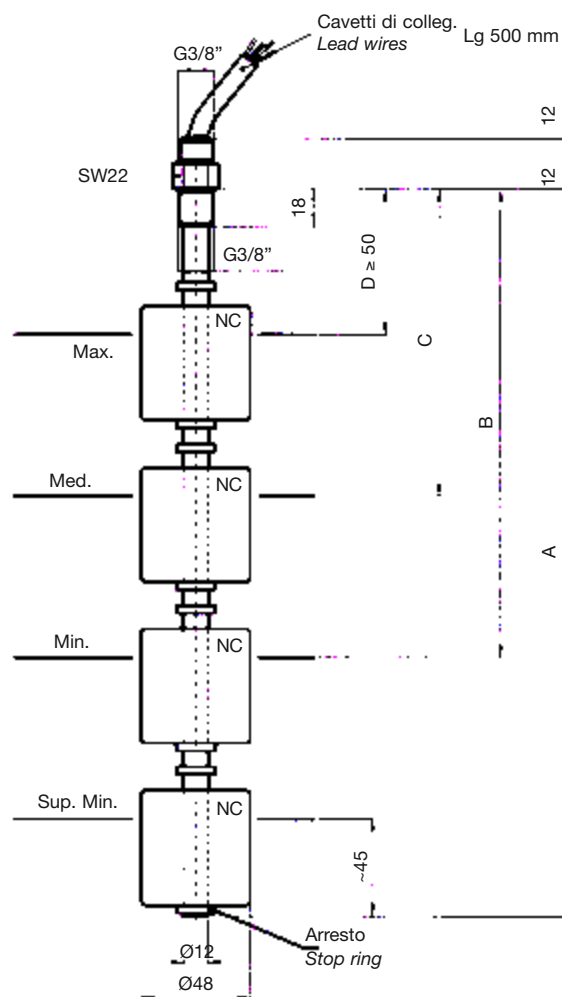

N.B. - When ordering, according to the model required, indicate A - B - C - D references.
 Min. contact distance B - C - D = 90 mm.
 Ordering example: LM4GSA800B600C200D50
 Executions with N/O or SPDT contacts are available on request.

USE

This series of electromagnetic level switches has been designed to check the level in a tank and send an electric signal to a remote board in case the fluid goes over or under the established levels. They must be set vertically on the cover of the tank, with the float at least 50 mm far from the metal walls.

SPECIFICATIONS

Stem max length	A = 2500 mm
Switching capacity in DC	60 W
Switching capacity in AC	60 VA
Current	0,8 A (resistive)
Voltage	~220 V - 50 Hz
Breakdown voltage	300 V
Capacitance	0,6 pF
Insulation resistance	10 ¹⁰ Ohm
Contact (dry condition)	NC
WITH SPDT CONTACTS (SC)	
Switching capacity	30 W
Current	0,5 A (resistive)
Insulation resistance	10 ⁹ Ohm min.
Capacitance	2 pF
Temperature range	-10 +80°C
Fluid specific gravity	≥0,7
Maximum pressure	10 Bar
Fluid viscosity	max 150 cSt
Material	Brass body - NBR float

WITH INDUCTIVE LOADS A PROTECTION CIRCUIT IS TO BE USED.

LIVELLOSTATI ELETTROMAGNETICI

Float level switches

LM1GA... LM2GA...

LMM1GA...B...

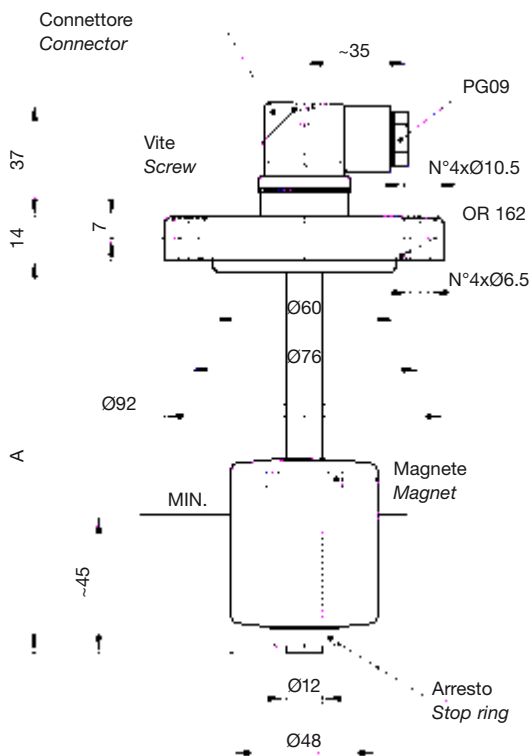

Collegamenti elettrici standard
Standard electrical connection

LM1GA

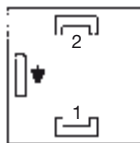

LM2GA

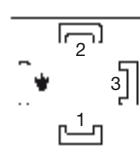

LMM1GA

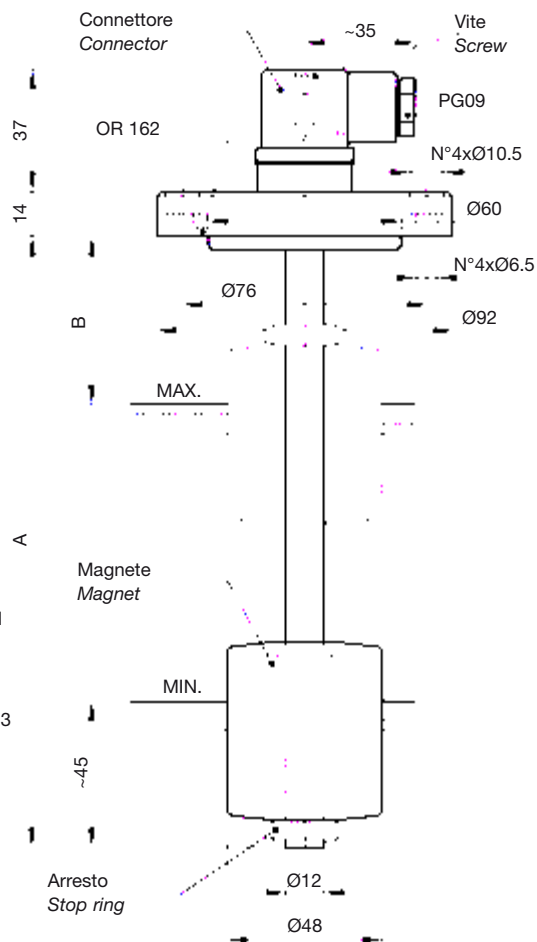
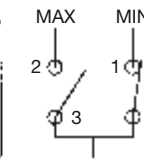
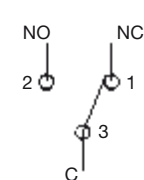
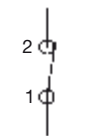
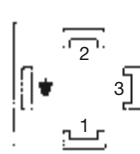

MATERIALI: flangia in alluminio anodizzato, tubo in ottone, anelli di arresto in bronzo, galleggiante in resina espansa NBR.

IMPIEGO E DATI TECNICI (vedere pag. 4 - 5 - 6 - 7).

N.B. - A richiesta, forniamo lunghezze superiori, fino a 2500 m, oppure diverse da quelle indicate in tabella.

 Disponibili in versione conforme alla Direttiva ATEX 94/9/CE in esecuzione a sicurezza intrinseca con stringa di certificazione II 1/2 G Ex ia IIB T6.

MATERIAL: flange in anodized aluminium; brass stem; stop rings in bronze, NBR float.

APPLICATION AND SPECIFICATIONS (see pages 4 - 5 - 6 - 7).

N.B. - Customized lengths can be supplied on request. Max. length 2500 mm.

 Executions also available in accordance with the Directive ATEX 94/9/EC on intrinsic safety equipment with marking II 1/2 G Ex ia IIB T6.

LM1GA...		LM2GA...		LMM1GA...B...		
TIPO Model	A	TIPO Model	A	TIPO Model	A	B
LM1GA150	150	LM2GA150	150	LMM1GA150B50	150	50
LM1GA200	200	LM2GA200	200	LMM1GA200B60	200	60
LM1GA250	250	LM2GA250	250	LMM1GA250B60	250	60
LM1GA300	300	LM2GA300	300	LMM1GA300B60	300	60
LM1GA350	350	LM2GA350	350	LMM1GA350B60	350	60
LM1GA400	400	LM2GA400	400	LMM1GA400B70	400	70
LM1GA450	450	LM2GA450	450	LMM1GA450B70	450	70
LM1GA500	500	LM2GA500	500	LMM1GA500B80	500	80

LIVELLOSTATI ELETTROMAGNETICI

Float level switches

LM1GTA... LM2GTA...

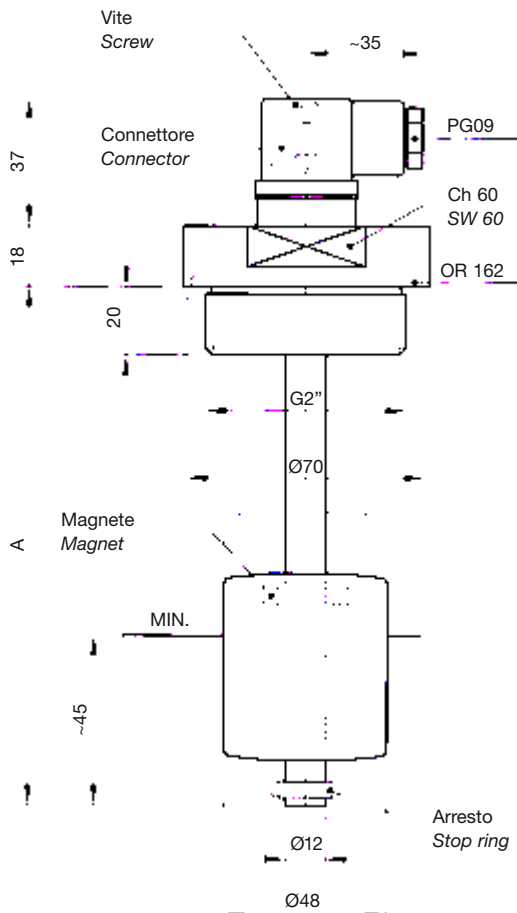

Collegamenti elettrici standard
Standard electrical connection

LM1GTA

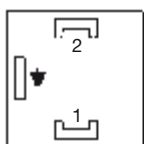

LM2GTA

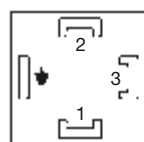

LMM1GTA

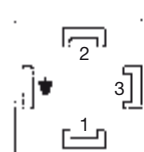

LMM1GTA...B...

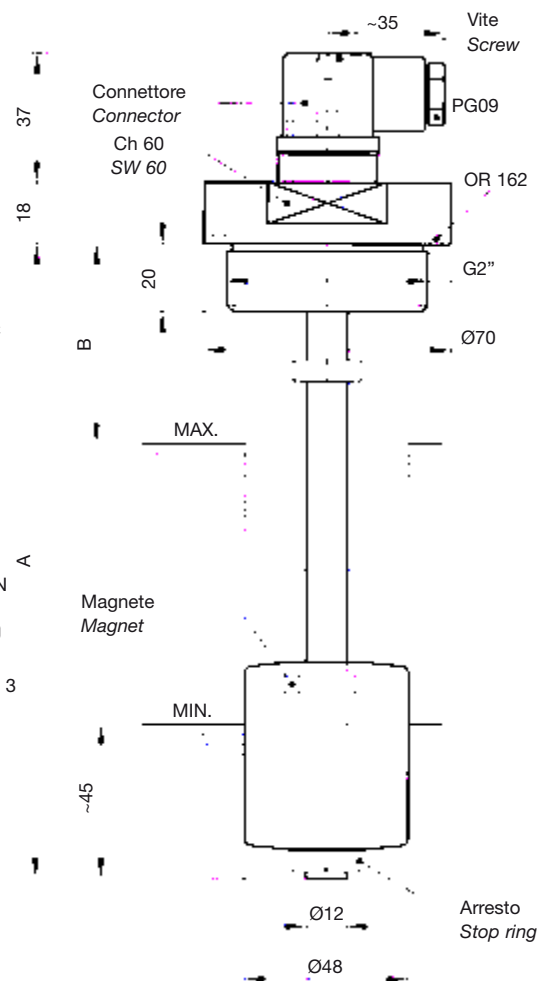

MATERIALI: flangia filettata in alluminio anodizzato, tubo in ottone, anelli di arresto in bronzo, galleggiante in resina espansa NBR.

IMPIEGO E DATI TECNICI (vedere pag. 4 - 5 - 6 - 7).

N.B. - A richiesta, forniamo lunghezze superiori, fino a 2500 mm, oppure diverse da quelle indicate in tabella.

 Disponibili in versione conforme alla Direttiva ATEX 94/9/CE in esecuzione a sicurezza intrinseca con stringa di certificazione II 1/2 G Ex ia IIB T6.

MATERIAL: threaded flange in anodized aluminium; brass stem; stop rings in bronze; NBR float.

APPLICATION AND SPECIFICATIONS (see pages 4 - 5 - 6 - 7).

N.B. - Customized lengths can be supplied on request. Max. length 2500 mm.

 Executions also available in accordance with the Directive ATEX 94/9/EC on intrinsic safety equipment with marking II 1/2 G Ex ia IIB T6.

LM1GTA...		LM2GTA...		LMM1GTA...B...		
TIPO Model	A	TIPO Model	A	TIPO Model	A	B
LM1GTA150	150	LM2GTA150	150	LMM1GTA150B50	150	50
LM1GTA200	200	LM2GTA200	200	LMM1GTA200B60	200	60
LM1GTA250	250	LM2GTA250	250	LMM1GTA250B60	250	60
LM1GTA300	300	LM2GTA300	300	LMM1GTA300B60	300	60
LM1GTA350	350	LM2GTA350	350	LMM1GTA350B60	350	60
LM1GTA400	400	LM2GTA400	400	LMM1GTA400B70	400	70
LM1GTA450	450	LM2GTA450	450	LMM1GTA450B70	450	70
LM1GTA500	500	LM2GTA500	500	LMM1GTA500B80	500	80

LIVELLOSTATI ELETTROMAGNETICI

Float level switches

LM4 GA... B... C... D...

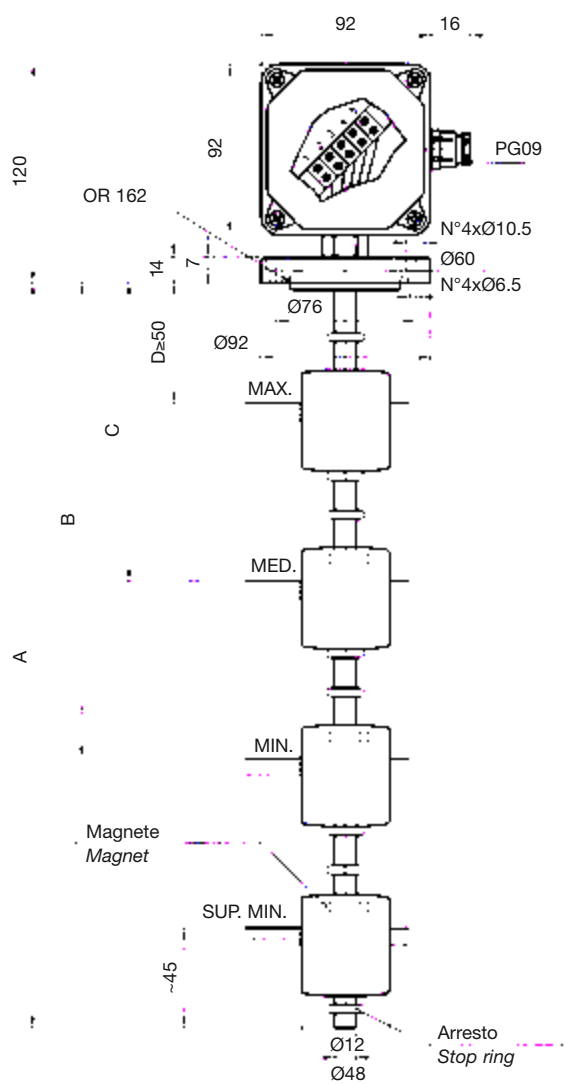

N.B. - Negli ordini, a seconda del modello, indicare le quote A - B - C - D. Min. distanza fra i contatti B - C - D = 90 mm.

Esempio di ordinazione: LM4GA800B600C200D50

 Disponibili in versione conforme alla Direttiva ATEX 94/9/CE in esecuzione a sicurezza intrinseca con stringa di certificazione II 1/2 G Ex ia IIB T6.

IMPIEGO

Sono stati studiati per controllare il livello di olio, acqua, solventi, in un serbatoio e per inviare a distanza un segnale elettrico. Devono essere montati verticalmente sul coperchio del serbatoio in modo che il galleggiante disti almeno 50 mm. dalle pareti metalliche.

DATI TECNICI

Lunghezza asta max	A = 2500 mm
Potenza commutabile in CC	60 W
Potenza commutabile in CA	60 VA
Intensità di corrente	0.8 A (resistivi)
Tensione max. di lavoro	220 V - 50 Hz
Tensione di breakdown	300 V
Capacità dei contatti aperti	0,6 pF
Contatti a riposo (senza fluido)	NC (NA su richiesta)
Resistenza d'isolamento	10 ¹⁰ Ohm
Campo di temperatura	-10 +80°C
Peso specifico liquido	≥ 0,7
Pressione massima	10 Bar
Viscosità del fluido	max 150 cSt

MATERIALI: flangia in alluminio anodizzato, tubo in ottone, anelli di arresto in bronzo, galleggiante in resina espansa NBR

PER CARICHI INDUTTIVI IMPIEGARE CIRCUITO DI PROTEZIONE.

LM3 GA... B... C...

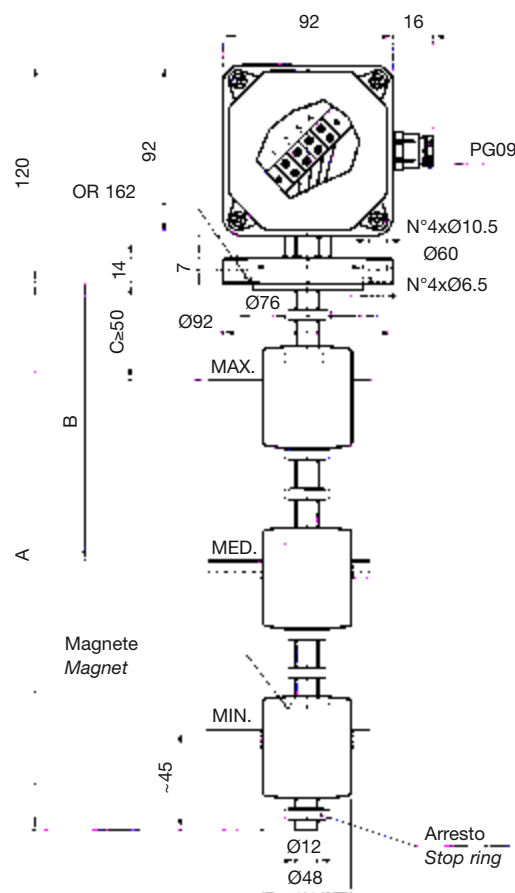

N.B. - In the order, according to the model required, indicate A - B - C - D references. Min. contact distance B - C - D = 90 mm.

Ordering example: LM3GA600B300C50

 Executions also available in accordance with the Directive ATEX 94/9/EC on intrinsic safety equipment with marking II 1/2 G Ex ia IIB T6.

USE

This series of electromagnetic level switches has been designed to check the level of oil, water, solvents in a tank and send an electric signal to a remote board in case the fluid goes over or under the set levels. They should be fixed vertically on the cover of the tank, with the float at least 50 mm far from metal walls.

SPECIFICATIONS

Stem max length	A = 2500 mm
Switching capacity in DC	60 W
Switching capacity in AC	60 VA
Current	0.8 A (resistive)
Voltage	220 V - 50 Hz
Breakdown voltage	300 V
Capacitance	0,6 pF
Contact (dry condition)	NC (NO on request)
Insulation resistance	10 ¹⁰ Ohm
Temperature range	-10 +80°C
Fluid specific gravity	≥ 0,7
Maximum pressure	10 Bar
Fluid viscosity	max 150 cSt

MATERIAL: flange in anodized aluminium; brass stem; stop rings in bronze; NBR float.

WITH INDUCTIVE LOADS A PROTECTION CIRCUIT IS TO BE USED.

LIVELLOSTATI ELETTROMAGNETICI

Float level switches

LM3 GTA... B... C...

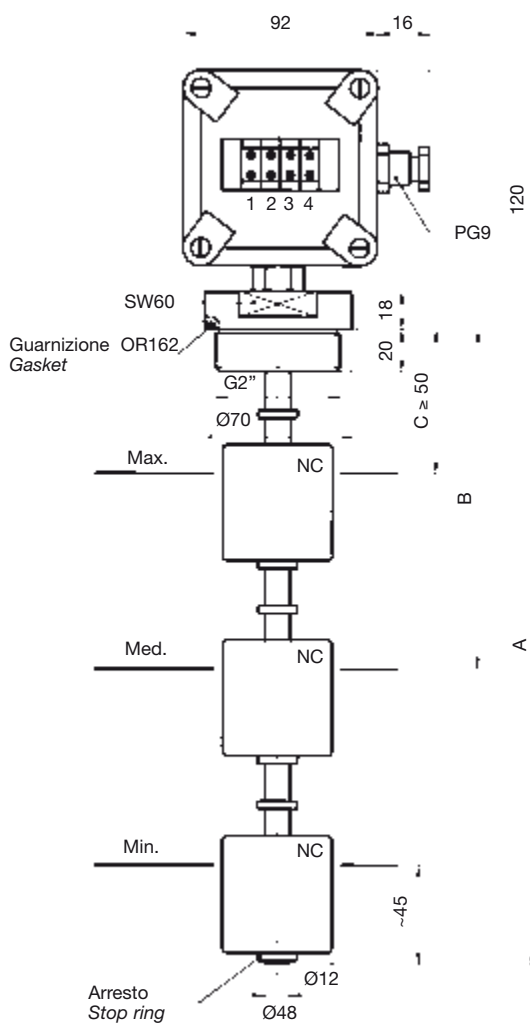

N.B. - Negli ordini, a seconda del modello, indicare le quote A - B - C - D. Min. distanza fra i contatti B - C - D = 90 mm.

Esempio di ordinazione: LM3GTA600B400C200



Disponibili in versione conforme alla Direttiva ATEX 94/9/CE in esecuzione a sicurezza intrinseca con stringa di certificazione II 1/2 G Ex ia IIB T6.

IMPIEGO

Sono stati studiati per controllare il livello di olio, acqua, solventi, in un serbatoio e per inviare a distanza un segnale elettrico. Devono essere montati verticalmente sul coperchio del serbatoio in modo che il galleggiante disti almeno 50 mm. dalle pareti metalliche.

DATI TECNICI

Lunghezza asta max	A = 2500 mm
Potenza commutabile in CC	60 W
Potenza commutabile in CA	60 VA
Intensità di corrente	0.8 A (resistivi)
Tensione max. di lavoro	220 V - 50 Hz
Tensione di breakdown	300 V
Capacità dei contatti aperti	0,6 pF
Contatto a riposo (senza fluido)	NC (NA su richiesta)
Resistenza d'isolamento	10 ¹⁰ Ohm
Campo di temperatura	-10 +80°C
Peso specifico liquido	≥ 0,7
Pressione massima	10 Bar
Viscosità del fluido	max 150 cSt

MATERIALI: flangia filettata in alluminio anodizzato, tubo in ottone, anelli di arresto in bronzo, galleggiante in resina espansa NBR.

PER CARICHI INDUTTIVI IMPIEGARE CIRCUITO DI PROTEZIONE.

LM4 GTA... B... C... D...

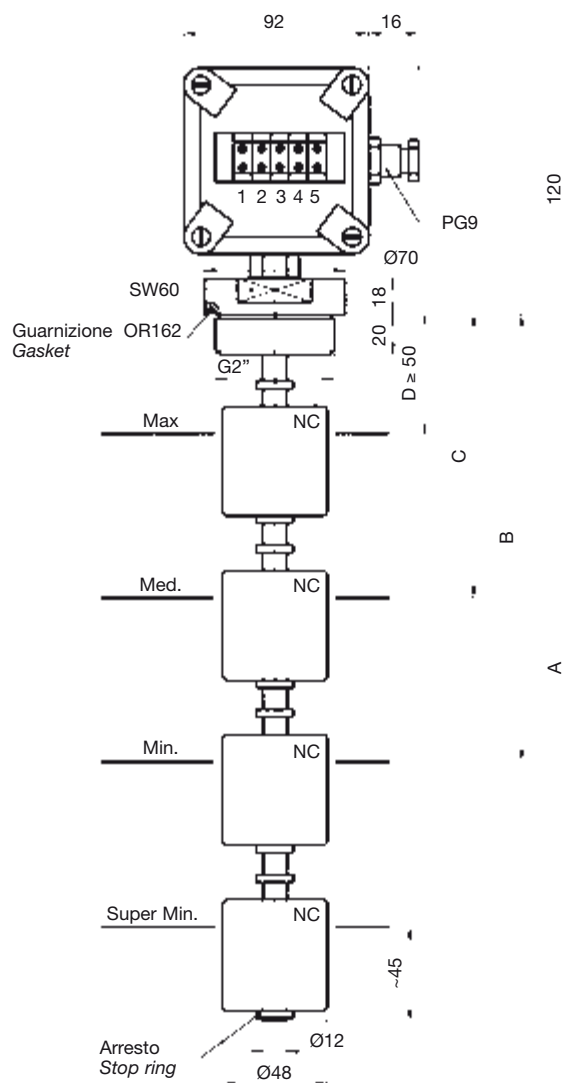

N.B. - When ordering, according to the model required, indicate A - B - C - D references. Min. contact distance B - C - D = 90 mm.

Ordering example: LM4GTA1500B800C600D100



Executions also available in accordance with the Directive ATEX 94/9/EC on intrinsic safety equipment with marking II 1/2 G Ex ia IIB T6.

USE

This series of electromagnetic level switches has been designed to check the level of oil, water, solvents in a tank and send an electric signal to a remote board in case the fluid goes over or under the set levels. They should be fixed vertically on the cover of the tank, with the float at least 50 mm far from metal walls.

SPECIFICATIONS

Stem max length	A = 2500 mm
Switching capacity in DC	60 W
Switching capacity in AC	60 VA
Current	0.8 A (resistive)
Voltage	220 V - 50 Hz
Breakdown voltage	300 V
Capacitance	0,6 pF
Contact (dry condition)	NC (NO on request)
Insulation resistance	10 ¹⁰ Ohm
Temperature range	-10 +80°C
Fluid specific weight	≥ 0,7
Maximum pressure	10 Bar
Fluid viscosity	max 150 cSt

MATERIAL: threaded flange in anodized aluminium; brass stem; stop rings in bronze; NBR float.

WITH INDUCTIVE LOADS A PROTECTION CIRCUIT IS TO BE USED.

LIVELLOSTATI ELETTROMAGNETICI - INOX

Float level switches - Stainless steel

LM1GSIA... LM2GSIA...

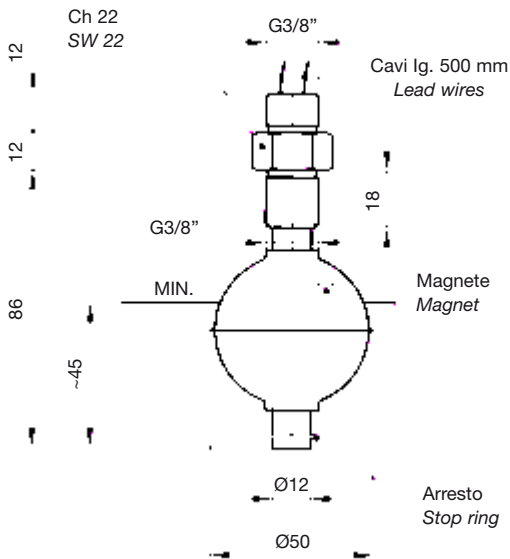

Schema di applicazione
Application chart

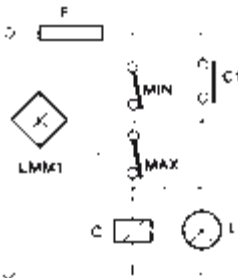
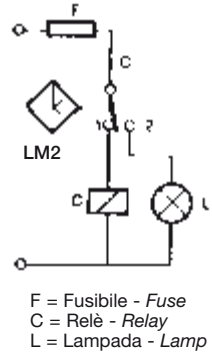

Riempimento automatico
Automatic filling

LMM1GSIA...B...

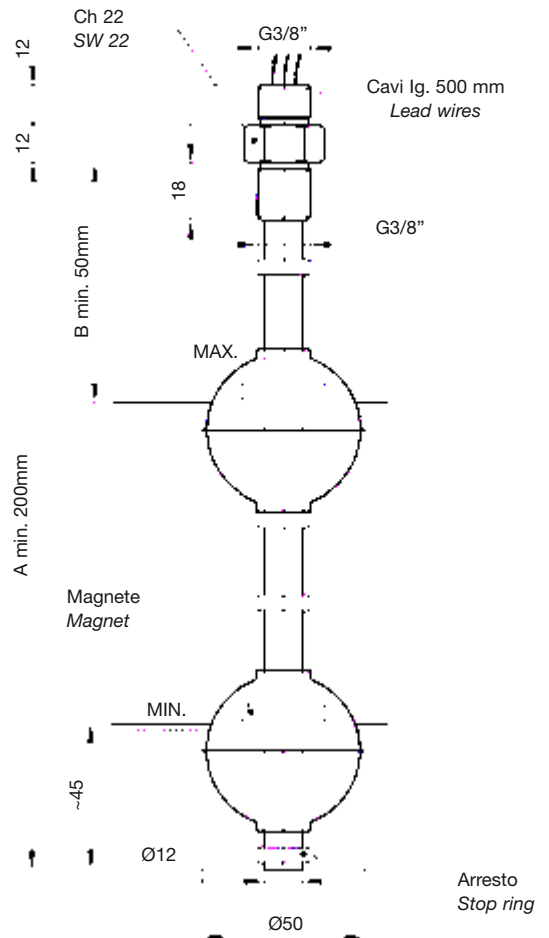

N.B. Nelle ordinazioni indicare le quote A e B.
N.B. When ordering indicate A and B references.

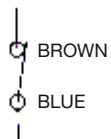

LM1GSIA

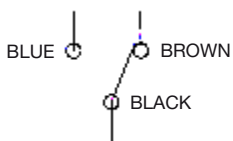

LM2GSIA

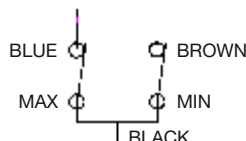

**LMM1GSIA
MIN - MAX CONTACTS**

IMPIEGO

Sono stati studiati per controllare il minimo o il massimo livello di olio, acqua, solventi, in un serbatoio e inviare a distanza un segnale elettrico. Devono essere montati verticalmente sul coperchio del serbatoio in modo che il galleggiante disti almeno 50 mm. dalle pareti metalliche.

DATI TECNICI

Potenza commutabile in CC	60 W
Potenza commutabile in CA	60 VA
Intensità di corrente	0.8 A (resistivi)
Tensione max. di lavoro	220 V - 50 Hz
Tensione di breakdown	300 V
Capacità dei contatti aperti	0,6 pF
Resistenza d'isolamento	10 ¹⁰ Ohm min.
Contatto a riposo (senza fluido)	NC

CON CONTATTI SPDT (SC)

Potenza commutabile	30 W
Corrente commutabile	0,5 A (resistivi)
Resistenza d'isolamento	10 ⁹ Ohm min.
Capacità dei contatti	2 pF
Campo di temperatura	-10 +80°C
Peso specifico liquido	≥0,7
Pressione massima	10 Bar
Viscosità del fluido	max 150 cSt
Materiale	Acciaio inox AISI 316

PER CARICHI INDUTTIVI IMPIEGARE CIRCUITO DI PROTEZIONE.

USE

This series of electromagnetic level switches has been designed to check the minimum or maximum level of oil, water, solvents in a tank and send an electric signal to a remote board in case the fluid goes over or under the set levels. They should be fixed vertically on the cover of the tank, with the float at least 50 mm far from metal walls.

SPECIFICATIONS

Switching capacity in DC	60 W
Switching capacity in AC	60 VA
Current	0.8 A (resistive)
Voltage	220 V - 50 Hz
Breakdown voltage	300 V
Capacitance	0,6 pF
Insulation resistance	10 ¹⁰ Ohm
Contact (dry condition)	NC
WITH SPDT CONTACTS	
Switching capacity	30 W
Current	0.5 A (resistive)
Insulation resistance	10 ⁹ OHM min.
Switching capacity	2 pf
Temperature range	-10 +80°C
Fluid specific weight	≥0,7
Maximum pressure	10 Bar
Fluid viscosity	max 150 cSt
Material	Stainless steel AISI 316

WITH INDUCTIVE LOADS A PROTECTION CIRCUIT IS TO BE USED.

LIVELLOSTATI ELETTROMAGNETICI - INOX

Float level switches - Stainless steel

LM3 GSIA... B... C...

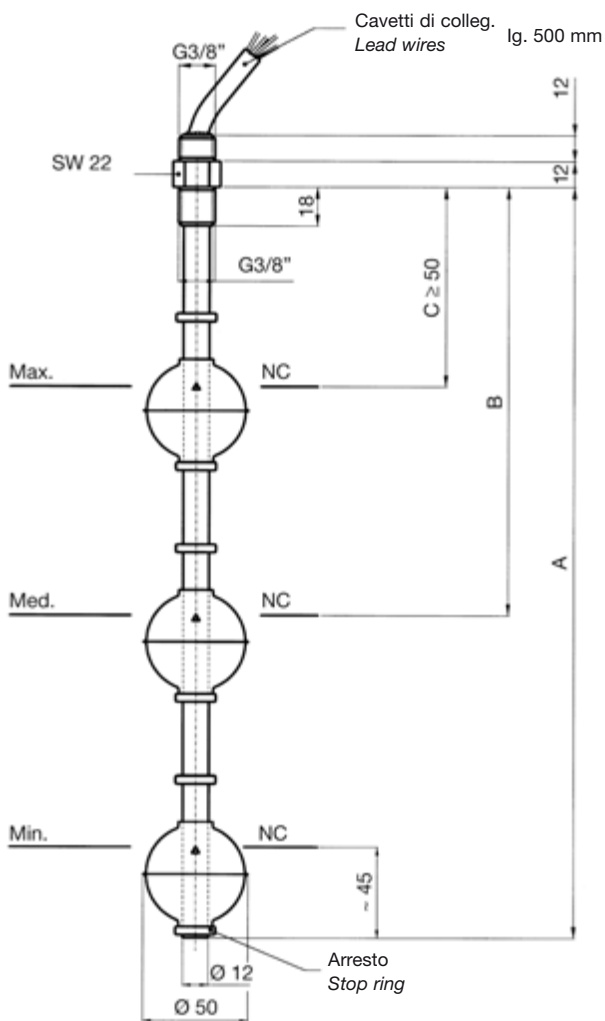

LM4 GSIA... B... C... D...

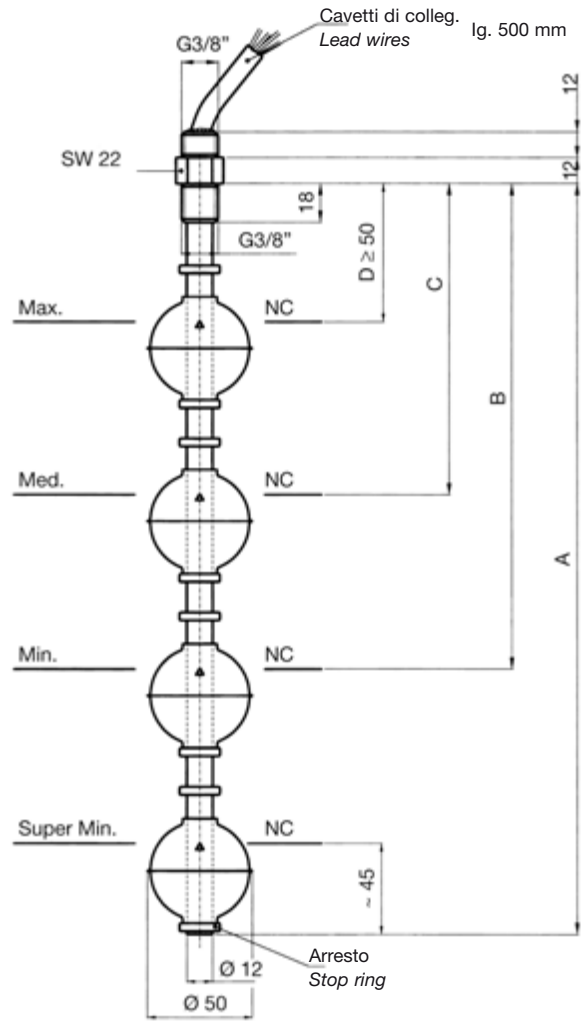

N.B. - Negli ordini, a seconda del modello indicare le quote A - B - C - D.
Min. distanza fra i contatti B - C - D = 90 mm.
Esempio di ordinazione: LM3GSIA1000B800C50
Su richiesta sono disponibili versioni con contatti NA o SPDT.

N.B. - When ordering, according to the model required, indicate A - B - C - D references.
Min contact distance B - C - D = 90 mm.
Ordering example: LM4GSIA1000B800C600D400
Executions with N/O or SPDT contacts are available on request.

IMPIEGO

Sono stati studiati per controllare il minimo o il massimo livello di olio, acqua, solventi, in un serbatoio e inviare a distanza un segnale elettrico. A seconda dei tipi, devono essere montati verticalmente sul coperchio del serbatoio in modo che il galleggiante disti almeno 50 mm. dalle pareti metalliche.

USE

This series of electromagnetic level switches has been designed to check the minimum or maximum level of oil, water, solvents in a tank and send an electric signal to a remote board in case the fluid goes over or under the set levels. They should be fixed vertically on the cover of the tank, with the float at least 50 mm far from metal walls.

DATI TECNICI

Lunghezza asta max	A = 2500 mm
Potenza commutabile in CC	60 W
Potenza commutabile in CA	60 VA
Intensità di corrente	0.8 A (resistivi)
Tensione max. di lavoro	220 V - 50 Hz
Tensione di breakdown	300 V
Capacità dei contatti aperti	0,6 pF
Resistenza d'isolamento	10 ¹⁰ Ohm min.
Contatto a riposo (senza fluido)	NC

CON CONTATTI SPDT (SC)

Potenza commutabile	30 W
Corrente commutabile	0,5 A (resistivi)
Resistenza d'isolamento	10 ⁹ Ohm min.
Capacità dei contatti	2 pF
Campo di temperatura	-10 +80°C
Peso specifico liquido	≥0,7
Pressione massima	10 Bar
Viscosità del fluido	max 150 cSt
Materiale	Acciaio inox AISI 316

SPECIFICATIONS

Stem max length	A = 2500 mm
Switching capacity in DC	60 W
Switching capacity in AC	60 VA
Current	0.8 A (resistive)
Voltage	220 V - 50 Hz
Breakdown voltage	300 V
Capacitance	0,6 pF
Insulation resistance	10 ¹⁰ Ohm
Contacts (dry condition)	NC

WITH SPDT CONTACTS (SC)

Switching capacity	30 W
Current	0.5 A (resistive)
Insulation resistance	10 ⁹ Ohm min.
Capacitance	2 pF
Temperature range	-10 +80°C
Fluid specific weight	≥0,7
Maximum pressure	10 Bar
Fluid viscosity	max 150 cSt
Material	Stainless steel AISI 316

PER CARICHI INDUTTIVI IMPIEGARE CIRCUITO DI PROTEZIONE.

WITH INDUCTIVE LOADS A PROTECTION CIRCUIT IS TO BE USED.

LIVELLOSTATI ELETTROMAGNETICI - INOX

Float level switches - Stainless steel

LM1GIA... LM2GIA...

LMM1GIA...B...

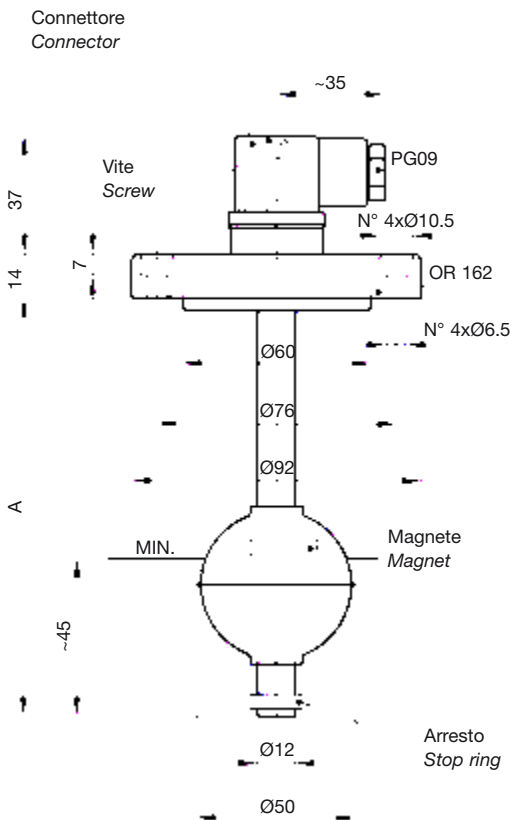

Collegamenti elettrici standard
Standard electrical connection

LM1GIA

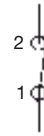
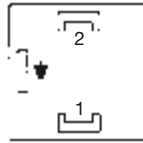

LM2GIA

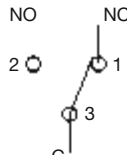
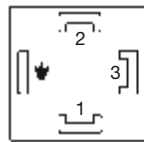

LMM1GIA

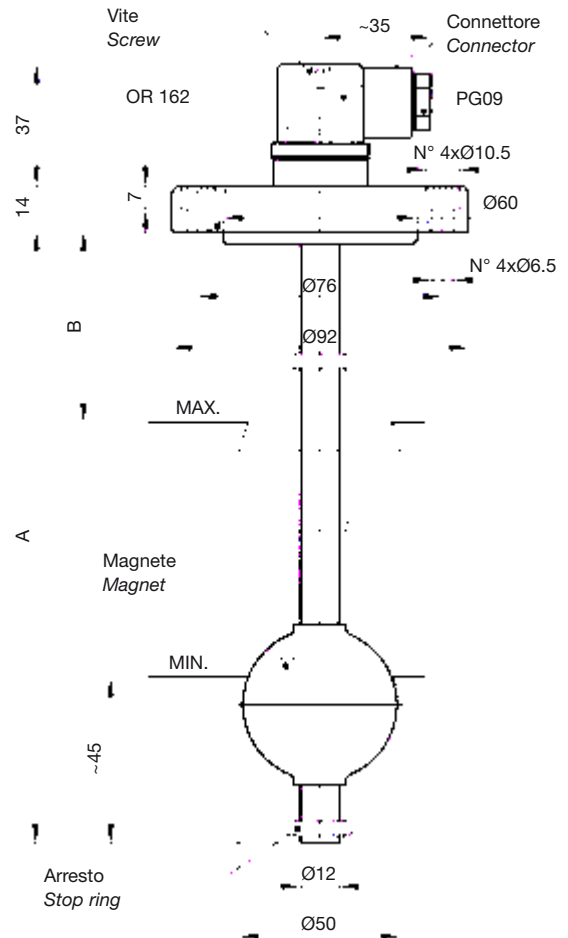
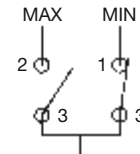
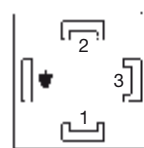

MATERIALE: flangia, tubo, anelli di arresto e galleggiante in acciaio inox.

IMPIEGO E DATI TECNICI (vedere pag. 4 - 5 - 6 - 7).

N.B. - A richiesta, forniamo lunghezze superiori, fino a 2500 mm, oppure diverse da quelle indicate in tabella.



Disponibili in versione conforme alla Direttiva ATEX 94/9/CE in esecuzione a sicurezza intrinseca con stringa di certificazione II 1/2 G Ex ia IIC T6.

MATERIAL: flange, stem, stop rings and float in stainless steel.

APPLICATION AND SPECIFICATIONS (see pages 4 - 5 - 6 - 7).

N.B. - Customized lengths can be supplied on request. Max. length 2500 mm.



Executions also available in accordance with the Directive ATEX 94/9/EC on intrinsic safety equipment with marking II 1/2 G Ex ia IIC T6.

LM1GIA...		LM2GIA...		LMM1GIA...B...		
TIPO Model	A	TIPO Model	A	TIPO Model	A	B
LM1GIA150	150	LM2GIA150	150	LMM1GIA150B50	150	50
LM1GIA200	200	LM2GIA200	200	LMM1GIA200B60	200	60
LM1GIA250	250	LM2GIA250	250	LMM1GIA250B60	250	60
LM1GIA300	300	LM2GIA300	300	LMM1GIA300B60	300	60
LM1GIA350	350	LM2GIA350	350	LMM1GIA350B60	350	60
LM1GIA400	400	LM2GIA400	400	LMM1GIA400B70	400	70
LM1GIA450	450	LM2GIA450	450	LMM1GIA450B70	450	70
LM1GIA500	500	LM2GIA500	500	LMM1GIA500B80	500	80

LIVELLOSTATI ELETTROMAGNETICI - INOX

Float level switches - Stainless steel

LM1GTIA... LM2GTIA...

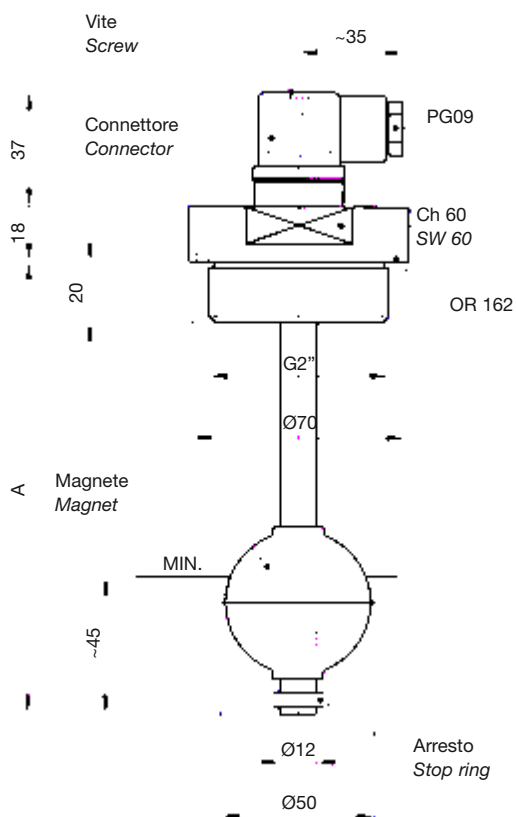

Collegamenti elettrici standard
Standard electrical connection

LM1GTIA

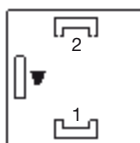

LM2GTIA

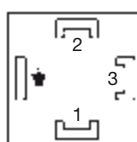

LMM1GTIA

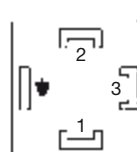

LMM1GTIA...B...

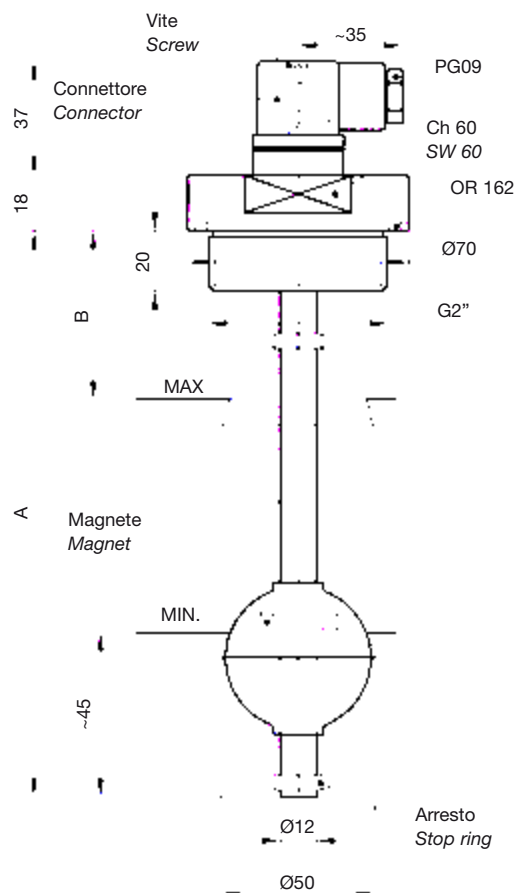

MATERIALE: flangia filettata, tubo, anelli di arresto e galleggiante in acciaio inox.

IMPIEGO E DATI TECNICI (vedere pag. 4 - 5 - 6 - 7).

N.B. - A richiesta, forniamo lunghezze superiori, fino a 2500 mm, oppure diverse da quelle indicate in tabella.

 Disponibili in versione conforme alla Direttiva ATEX 94/9/CE in esecuzione a sicurezza intrinseca con stringa di certificazione II 1/2 G Ex ia IIC T6.

MATERIAL: threaded flange, stem, stop rings and float in stainless steel.

APPLICATION AND SPECIFICATIONS (see pages 4 - 5 - 6 - 7).

N.B. - Customized lengths can be supplied on request. Max. length 2500 mm.

 Executions also available in accordance with the Directive ATEX 94/9/EC on intrinsic safety equipment with marking II 1/2 G Ex ia IIC T6.

LM1GTIA...		LM2GTIA...		LMM1GTIA...B...		
TIPO Model	A	TIPO Model	A	TIPO Model	A	B
LM1GTIA150	150	LM2GTIA150	150	LMM1GTIA150B50	150	50
LM1GTIA200	200	LM2GTIA200	200	LMM1GTIA200B60	200	60
LM1GTIA250	250	LM2GTIA250	250	LMM1GTIA250B60	250	60
LM1GTIA300	300	LM2GTIA300	300	LMM1GTIA300B60	300	60
LM1GTIA350	350	LM2GTIA350	350	LMM1GTIA350B60	350	60
LM1GTIA400	400	LM2GTIA400	400	LMM1GTIA400B70	400	70
LM1GTIA450	450	LM2GTIA450	450	LMM1GTIA450B70	450	70
LM1GTIA500	500	LM2GTIA500	500	LMM1GTIA500B80	500	80

LIVELLOSTATI ELETTROMAGNETICI - INOX

Float level switches - Stainless steel

LM4 GIA... B... C... D...

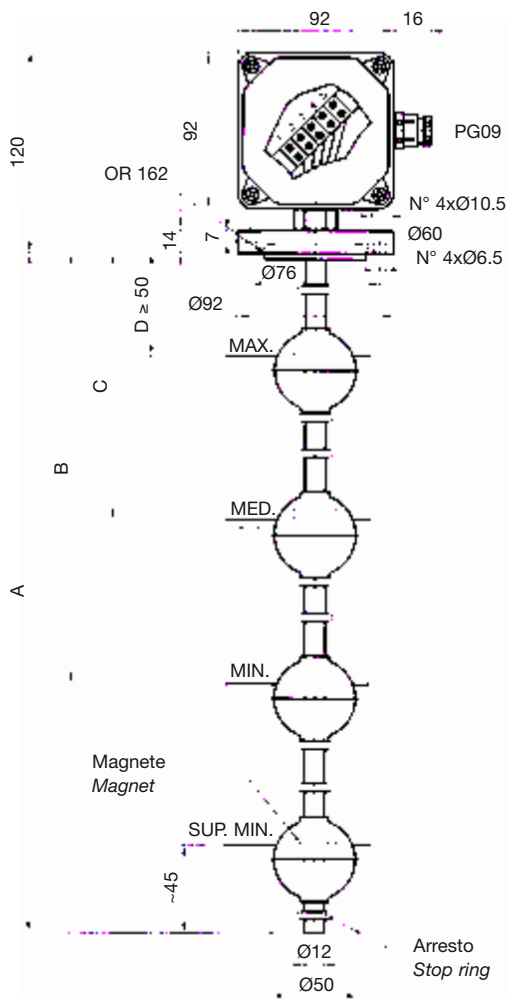

N.B. - Negli ordini, a seconda del modello, indicare le quote A - B - C - D. Min. distanza fra i contatti B - C - D = 90 mm.

Esempio di ordinazione: LM4GIA1500B1200C200D50

MATERIALE: flangia, tubo, anelli di arresto e galleggiante in acciaio inox.



Disponibili in versione conforme alla Direttiva ATEX 94/9/CE in esecuzione a sicurezza intrinseca con stringa di certificazione II 1/2 G Ex ia IIC T6.

IMPIEGO

Sono stati studiati per controllare il livello di olio, acqua, solventi, in un serbatoio e per inviare a distanza un segnale elettrico. A seconda dei tipi, devono essere montati verticalmente sul coperchio del serbatoio in modo che il galleggiante disti almeno 50 mm. dalle pareti metalliche.

DATI TECNICI

Lunghezza asta max	A = 2500 mm
Potenza commutabile in CC	60 W
Potenza commutabile in CA	60 VA
Intensità di corrente	0.8 A (resistivi)
Tensione max. di lavoro	220 V - 50 Hz
Tensione di breakdown	300 V
Capacità dei contatti aperti	0,6 pF
Contatto a riposo (senza fluido)	NC (NA su richiesta)
Resistenza d'isolamento	10 ¹⁰ Ohm
Campo di temperatura	-10 +80°C
Peso specifico liquido	≥ 0,7
Pressione massima	10 Bar
Viscosità del fluido	max 150 cSt

PER CARICHI INDUTTIVI IMPIEGARE CIRCUITO DI PROTEZIONE.

LM3 GIA... B... C...

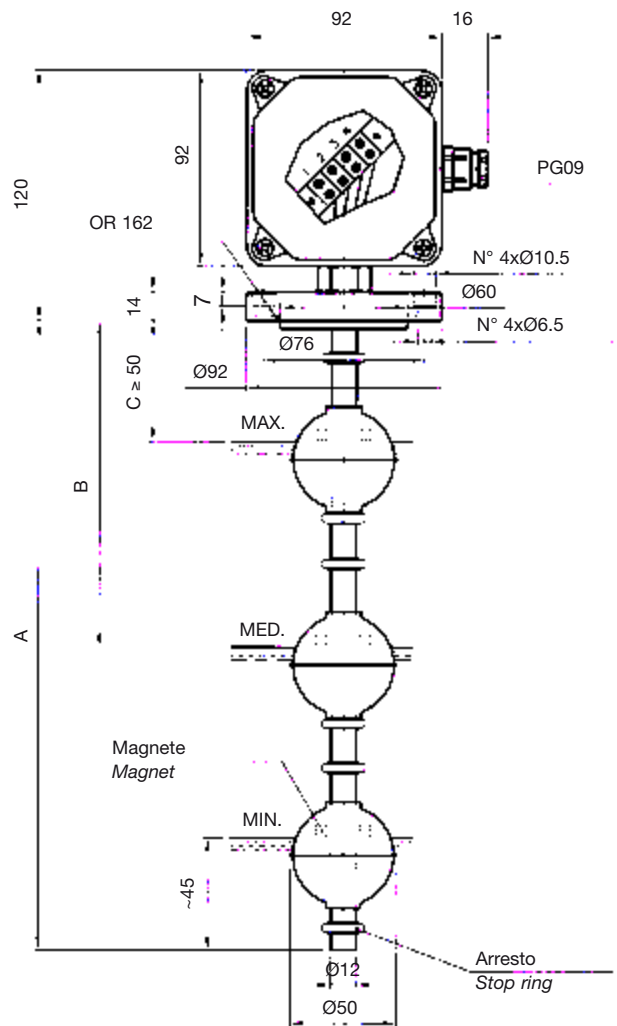

N.B. - When ordering, according to the model required, indicate the A - B - C - D references. Min. contact distances: B - C - D = 90 mm.

Ordering example: LM3GIA1000B600C50

MATERIAL: flange, stem, stop rings and float in stainless steel.



Executions also available in accordance with the Directive ATEX 94/9/EC on intrinsic safety equipment with marking II 1/2 G Ex ia IIC T6.

USE

This series of electromagnetic level switches has been designed to check the level of oil, water, solvents in a tank and send an electric signal to a remote board in case the fluid goes over or under the set levels. They should be fixed vertically on the cover of the tank, with the float at least 50 mm far from metal walls.

SPECIFICATIONS

Stem max length	A = 2500 mm
Switching capacity in DC	60 W
Switching capacity in AC	60 VA
Current	0.8 A (resistive)
Voltage	220 V - 50 Hz
Breakdown voltage	300 V
Capacitance	0,6 pF
Contact (dry condition)	NC (NO on request)
Insulation resistance	10 ¹⁰ Ohm
Temperature range	-10 +80°C
Fluid specific gravity	≥ 0,7
Maximum pressure	10 Bar
Fluid viscosity	max 150 cSt

WITH INDUCTIVE LOADS A PROTECTION CIRCUIT IS TO BE USED.

LIVELLOSTATI ELETTROMAGNETICI - INOX

Float level switches - Stainless steel

LM3 GTIA... B... C...

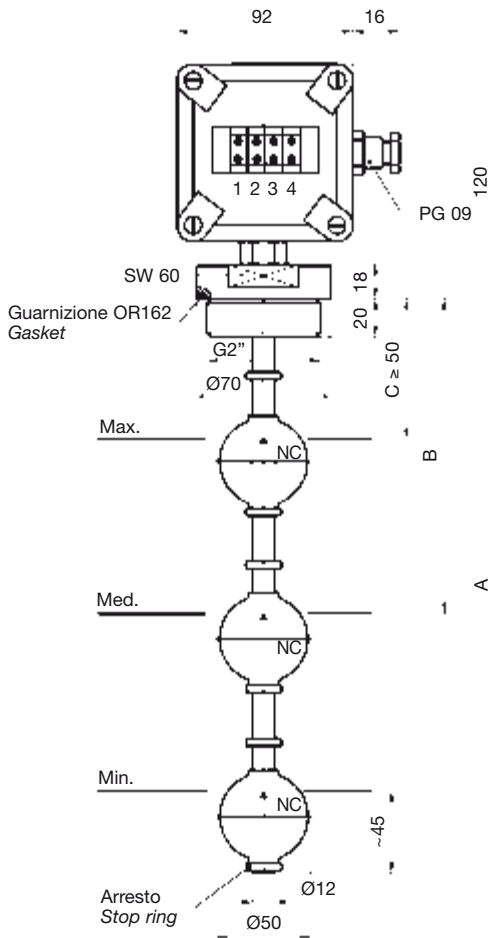

N.B. - Negli ordini, a seconda del modello, indicare le quote A - B - C - D. Min. distanza fra i contatti B - C - D = 90 mm.

Esempio di ordinazione: LM3GTIA1000B600C200

MATERIALE: flangia filettata, tubo, anelli di arresto e galleggiante in acciaio inox.



Disponibili in versione conforme alla Direttiva ATEX 94/9/CE in esecuzione a sicurezza intrinseca con stringa di certificazione II 1/2 G Ex ia IIC T6.

IMPIEGO

Sono stati studiati per controllare il livello di olio, acqua, solventi, in un serbatoio e per inviare a distanza un segnale elettrico. Devono essere montati verticalmente sul coperchio del serbatoio in modo che il galleggiante disti almeno 50 mm. dalle pareti metalliche.

DATI TECNICI

Lunghezza asta max	A = 2500 mm
Potenza commutabile in CC	60 W
Potenza commutabile in CA	60 VA
Intensità di corrente	0,8 A (resistivi)
Tensione max. di lavoro	220 V - 50 Hz
Tensione di breakdown	300 V
Capacità dei contatti aperti	0,6 pF
Contatto a riposo (senza fluido)	NC (NA su richiesta)
Resistenza d'isolamento	10 ¹⁰ Ohm
Campo di temperatura	-10 +80°C
Peso specifico liquido	≥ 0,7
Pressione massima	10 Bar
Viscosità del fluido	max 150 cSt

PER CARICHI INDUTTIVI IMPIEGARE CIRCUITO DI PROTEZIONE.

LM4 GTIA... B... C... D...

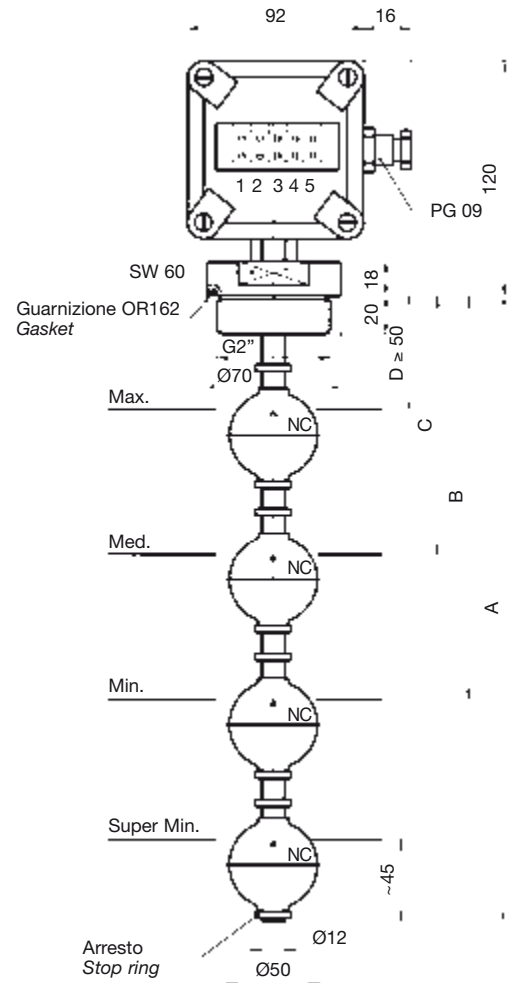

N.B. - When ordering, according to the model required indicate A - B - C - D references. Min. contact distance B - C - D = 90 mm.

Ordering example: LM4GTIA1500B1200C200D50

MATERIAL: threaded flange, stem, stop rings and float in stainless steel.



Executions also available in accordance with the Directive ATEX 94/9/EC on intrinsic safety equipment with marking II 1/2 G Ex ia IIC T6.

USE

This series of electromagnetic level switches has been designed to check the level of oil, water, solvents in a tank and send an electric signal to a remote board in case the fluid goes over or under the set levels. They should be fixed vertically on the cover of the tank, with the float at least 50 mm far from metal walls.

SPECIFICATIONS

Level max length	A = 2500 mm
Switching capacity in DC	60 W
Switching capacity in AC	60 VA
Current	0,8 A (resistive)
Voltage	220 V - 50 Hz
Breakdown voltage	300 V
Capacitance	0,6 pF
Contact (dry condition)	NC (NO on request)
Insulation resistance	10 ¹⁰ Ohm
Temperature range	-10 +80°C
Fluid specific gravity	≥ 0,7
Maximum pressure	10 Bar
Fluid viscosity	max 150 cSt

WITH INDUCTIVE LOADS A PROTECTION CIRCUIT IS TO BE USED.

LIVELLOSTATI ELETTROMAGNETICI

Conformi alla Direttiva 94/9/CE - II 1/2 GD Ex d IIB T6 Ex tD A21 IP65 T60°C



Float level switches

In accordance with Directive 94/9/EC - II 1/2 GD Ex d IIB T6 Ex tD A21 IP65 T60°C

LM1CTA... EP LM2CTA... EP

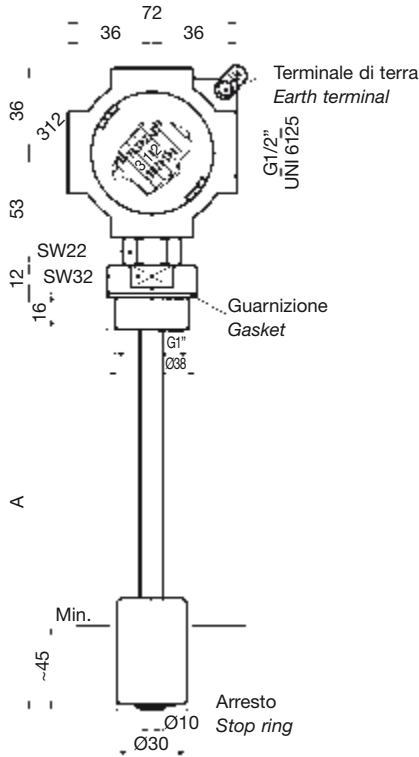

Collegamenti elettrici
Electrical connection

LM1CTA... EP



LM2CTA... EP

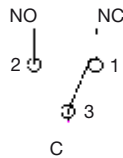

LMM1CTA... EP

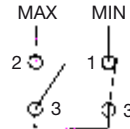

LMM1CTA... B... EP

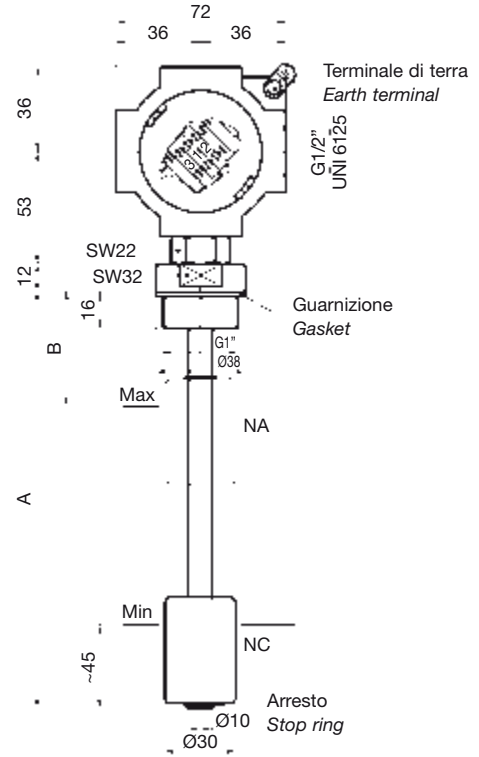

MATERIALI: flangia filettata in ottone, tubo in ottone, anelli di arresto in bronzo, galleggiante in resina espansa NBR, custodia in alluminio pressofuso verniciato.

N.B. - A richiesta, forniamo lunghezze superiori oppure diverse da quelle standard.

IMPIEGO

Sono stati studiati per controllare il livello di un liquido in un serbatoio e inviare a distanza un segnale elettrico. Devono essere montati verticalmente sul coperchio del serbatoio in modo che il galleggiante disti almeno 50 mm. dalle pareti metalliche.

DATI TECNICI COMUNI

Lunghezza asta max	A = 1500 mm
Campo di temperatura	-20°...+60°C
Peso specifico liquido	≥ 0,7
Pressione massima	10 Bar
Viscosità del fluido	max 150 cSt

DATI TECNICI LM1 - LMM1

Potenza commutabile in CC/CA	60 W/VA
Intensità di corrente	0,8 A (resistivi)
Tensione di lavoro	220 V - 50 Hz
Tensione di breakdown	300 V
Capacità dei contatti aperti	0,6 pF
Resistenza d'isolamento	10 ¹⁰ Ohm
Contatto a riposo (senza fluido)	
Livello min. (LM1-LMM1)	NC (NA su richiesta)
Livello max (LMM1)	NA (NC su richiesta)

DATI TECNICI LM2

Potenza commutabile in CC/CA	30 W/VA
Intensità di corrente	0,5 A (resistivi)
Tensione di lavoro	220 V - 50 Hz
Tensione di breakdown	300 V
Capacità dei contatti aperti	2 pF
Resistenza d'isolamento	10 ⁹ Ohm
Contatto a riposo	SPDT

MATERIAL: threaded flange in brass; brass stem; stop rings in bronze; NBR float, varnished die-cast aluminium housing.

N.B. - Customized executions can be supplied on request.

USE

This series of electromagnetic level switches has been designed to check a fluid level in a tank and send an electric signal to a remote board. They must be set vertically on the cover of the tank, with the float at least 50 mm far from metal walls.

COMMON SPECIFICATIONS

Stem max length	A = 1500 mm
Temperature range	-20°...+60°C
Fluid specific gravity	≥ 0,7
Maximum pressure	10 Bar
Fluid viscosity	max 150 cSt

LM1-LMM1 SPECIFICATIONS

Switching capacity in DC/AC	60 W/VA
Current	0,8 A (resistive)
Voltage	220 V - 50 Hz
Breakdown voltage	300 V
Capacitance	0,6 pF
Insulation resistance	10 ¹⁰ Ohm
Contact (dry condition)	
Min level (LM1-LMM1)	NC (NO on request)
Max level (LMM1)	NO (NC on request)

LM2 SPECIFICATIONS

Switching capacity in DC/AC	30 W/VA
Current	0,5 A (resistive)
Voltage	220 V - 50 Hz
Breakdown voltage	300 V
Capacitance	2 pF
Insulation resistance	10 ⁹ Ohm
Contact (dry condition)	SPDT

LIVELLOSTATI ELETTROMAGNETICI - INOX

Conformi alla Direttiva 94/9/CE - II 1/2 GD Ex d IIC T6 Ex tD A21 IP65 T60°C



Float level switches - Stainless steel

In accordance with Directive 94/9/EC - II 1/2 GD Ex d IIC T6 Ex tD A21 IP65 T60°C

LM1TIA... EP LM2TIA... EP

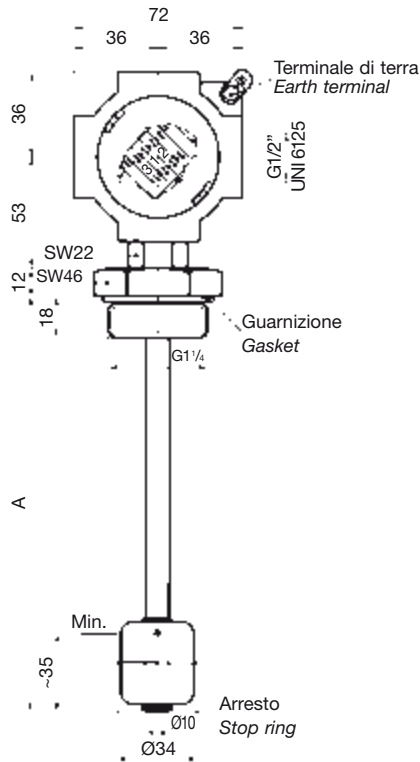

LM1TIA... EP

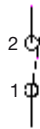

LM2TIA... EP

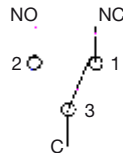

LMM1TIA... EP

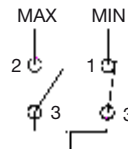

LMM1TIA... B... EP

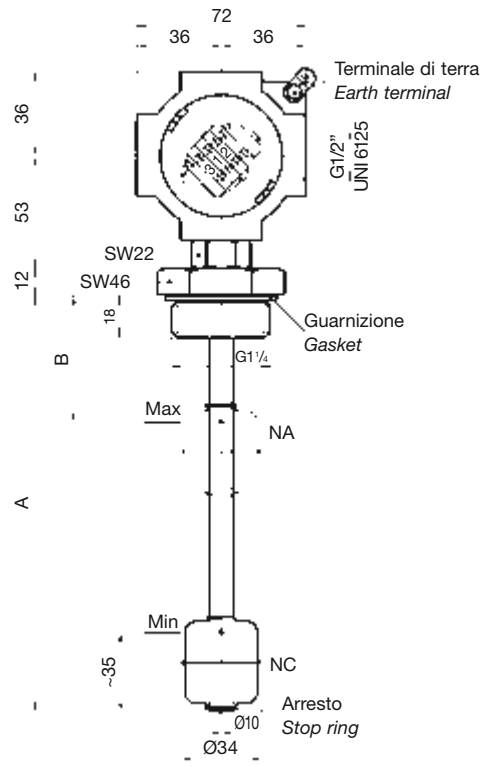

MATERIALI: flangia filettata G1 1/4" in inox; tubo, anelli di arresto e galleggianti in inox, custodia in alluminio pressofuso verniciato.

N.B. - A richiesta, forniamo lunghezze superiori oppure diverse da quelle standard.

IMPIEGO

Sono stati studiati per controllare il livello di un liquido in un serbatoio e inviare a distanza un segnale elettrico. Devono essere montati verticalmente sul coperchio del serbatoio in modo che il galleggiante disti almeno 50 mm. dalle pareti metalliche.

DATI TECNICI COMUNI

Lunghezza asta max	A = 1500 mm
Campo di temperatura	-20°...+60°C
Peso specifico liquido	≥ 0,7
Pressione massima	10 Bar
Viscosità del fluido	max 150 cSt

DATI TECNICI LM1 - LMM1

Potenza commutabile in CC/CA	60 W/VA
Intensità di corrente	0.8 A (resistivo)
Tensione di lavoro	220 V - 50 Hz
Tensione di breakdown	300 V
Capacità dei contatti aperti	0,6 pF
Resistenza d'isolamento	10 ¹⁰ Ohm
Contatto a riposo (senza fluido)	
Livello min. (LM1-LMM1)	NC (NA su richiesta)
Livello max (LMM1)	NA (NC su richiesta)

DATI TECNICI LM2

Potenza commutabile in CC/CA	30 W/VA
Intensità di corrente	0.5 A (resistivo)
Tensione di lavoro	220 V - 50 Hz
Tensione di breakdown	300 V
Capacità dei contatti aperti	2 pF
Resistenza d'isolamento	10 ⁹ Ohm
Contatto senza fluido	SPDT

MATERIAL: G1 1/4" threaded flange in stainless steel; stem, stop rings and float in stainless steel; varnished die-cast aluminium housing.

N.B. - Customized executions are available on request.

USE

This series of electromagnetic level switches has been designed to check a fluid level in a tank and send an electric signal to a remote board. They must be set vertically on the cover of the tank, with the float at least 50 mm far from the metal walls.

COMMON SPECIFICATIONS

Stem max length	A = 1500 mm
Temperature range	-20°...+60°C
Fluid specific gravity	≥ 0,7
Maximum pressure	10 Bar
Fluid viscosity	max 150 cSt

LM1-LMM1 SPECIFICATIONS

Switching capacity in DC/AC	60 W/VA
Current	0.8 A (resistive)
Voltage	220 V - 50 Hz
Breakdown voltage	300 V
Capacitance	0,6 pF
Insulation resistance	10 ¹⁰ Ohm
Contact (dry condition)	
Min level (LM1-LMM1)	NC (NO on request)
Max level (LMM1)	NO (NC on request)

LM2 SPECIFICATIONS

Switching capacity in DC/AC	30 W/VA
Current	0.5 A (resistive)
Voltage	220 V - 50 Hz
Breakdown voltage	300 V
Capacitance	2 pF
Insulation resistance	10 ⁹ Ohm
Contact (dry condition)	SPDT

LIVELLOSTATI ELETTROMAGNETICI

Conformi alla Direttiva 94/9/CE - II 1/2 GD Ex d IIB T6 Ex tD A21 IP65 T60°C



Float level switches

In accordance with Directive 94/9/EC - II 1/2 GD Ex d IIB T6 Ex tD A21 IP65 T60°C

LM1GTA... EP LM2GTA... EP

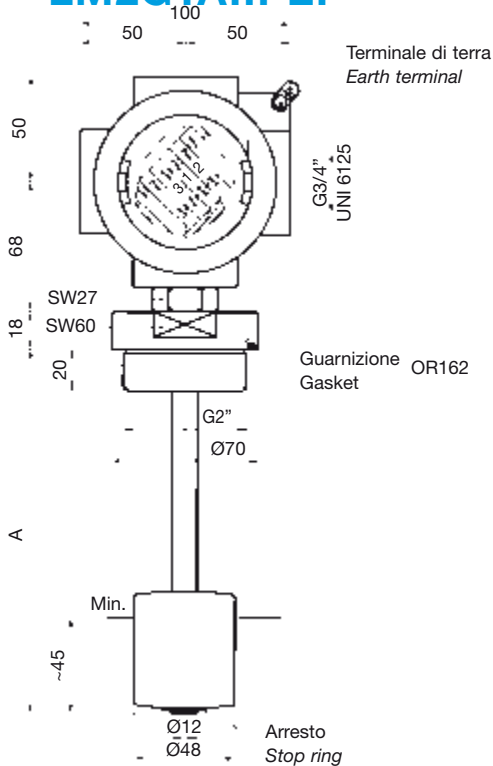

Collegamenti elettrici Electrical connection

LM1GTA... EP

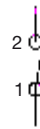

LM2GTA... EP

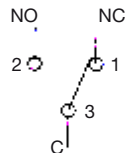

LMM1GTA... EP

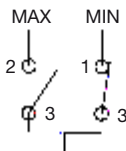

LMM1GTA... B... EP

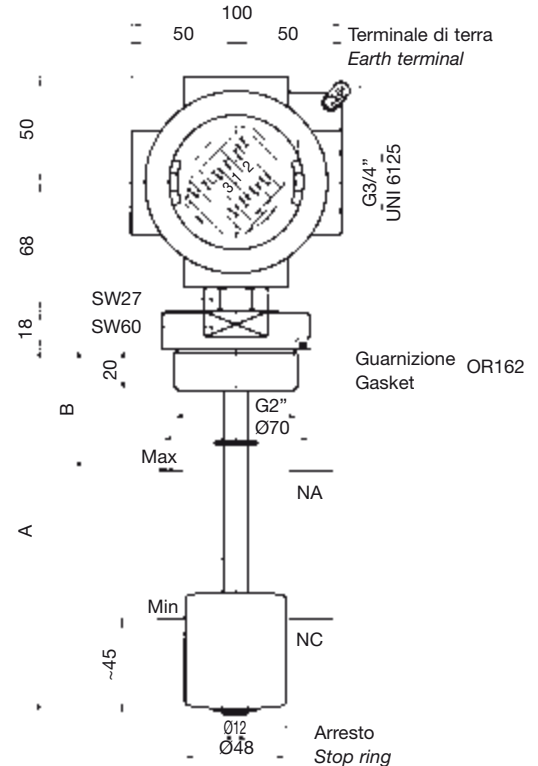

MATERIALI: flangia filettata in ottone, tubo in ottone, anelli di arresto in bronzo, galleggiante in resina espansa NBR, custodia in alluminio pressofuso verniciato.

N.B. - A richiesta, forniamo lunghezze superiori oppure diverse da quelle standard.

IMPIEGO

Sono stati studiati per controllare il livello di un liquido in un serbatoio e inviare a distanza un segnale elettrico. Devono essere montati verticalmente sul coperchio del serbatoio in modo che il galleggiante disti almeno 50 mm. dalle pareti metalliche.

DATI TECNICI COMUNI

Lunghezza asta max	A = 2500 mm
Campo di temperatura	-20°...+60°C
Peso specifico liquido	≥ 0,7
Pressione massima	20 Bar
Viscosità del fluido	max 150 cSt

DATI TECNICI LM1 - LMM1

Potenza commutabile in CC/CA	60 W/VA
Intensità di corrente	0.8 A (resistivo)
Tensione di lavoro	220 V - 50 Hz
Tensione di breakdown	300 V
Capacità dei contatti aperti	0,6 pF
Resistenza d'isolamento	10 ¹⁰ Ohm
Contatto a riposo (senza fluido)	
Livello min. (LM1-LMM1)	NC (NA su richiesta)
Livello max (LMM1)	NA (NC su richiesta)

DATI TECNICI LM2

Potenza commutabile in CC/CA	30 W/VA
Intensità di corrente	0.5 A (resistivo)
Tensione di lavoro	220 V - 50 Hz
Tensione di breakdown	300 V
Capacità dei contatti aperti	2 pF
Resistenza d'isolamento	10 ⁹ Ohm
Contatto a riposo	SPDT

MATERIAL: threaded flange in brass; brass stem; stop rings in bronze; NBR float, varnished die-cast aluminium housing.

N.B. - Customized executions can be supplied on request.

USE

This series of electromagnetic level switches has been designed to check a fluid level in a tank and send an electric signal to a remote board. They must be set vertically on the cover of the tank, with the float at least 50 mm far from metal walls.

COMMON SPECIFICATIONS

Stem max length	A = 2500 mm
Temperature range	-20°...+60°C
Fluid specific gravity	≥ 0,7
Maximum pressure	20 Bar
Fluid viscosity	max 150 cSt

LM1-LMM1 SPECIFICATIONS

Switching capacity in DC/AC	60 W/VA
Current	0.8 A (resistive)
Voltage	220 V - 50 Hz
Breakdown voltage	300 V
Capacitance	0,6 pF
Insulation resistance	10 ¹⁰ Ohm
Contact (dry condition)	
Min level (LM1-LMM1)	NC (NO on request)
Max level (LMM1)	NO (NC on request)

LM2 SPECIFICATIONS

Switching capacity in DC/AC	30 W/VA
Current	0.5 A (resistive)
Voltage	220 V - 50 Hz
Breakdown voltage	300 V
Capacitance	2 pF
Insulation resistance	10 ⁹ Ohm
Contact (dry condition)	SPDT

LIVELLOSTATI ELETTROMAGNETICI - INOX

Conformi alla Direttiva 94/9/CE - II 1/2 GD Ex d IIC T6 Ex tD A21 IP65 T60°C



Float level switches - Stainless steel

In accordance with Directive 94/9/EC - II 1/2 GD Ex d IIC T6 Ex tD A21 IP65 T60°C

LM1GTIA... EP LM2GTIA... EP

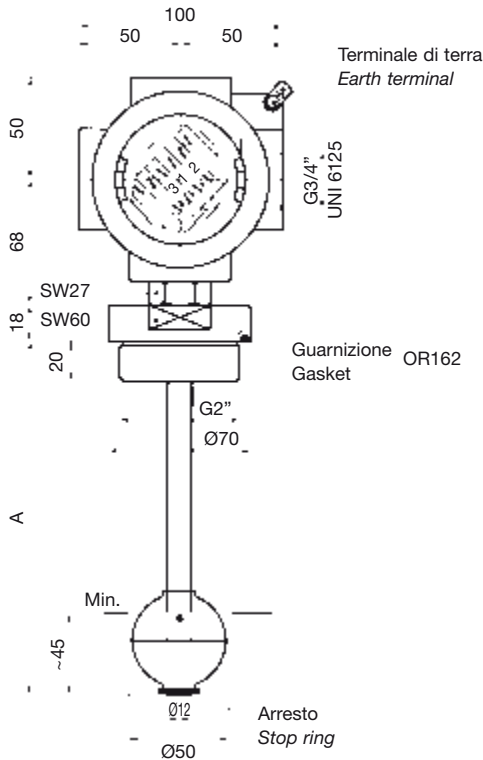

Collegamenti elettrici
Electrical connection

LM1GTIA... EP

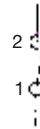

LM2GTIA... EP

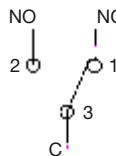

LMM1GTIA... EP

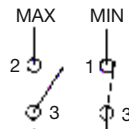

LMM1GTIA... B... EP

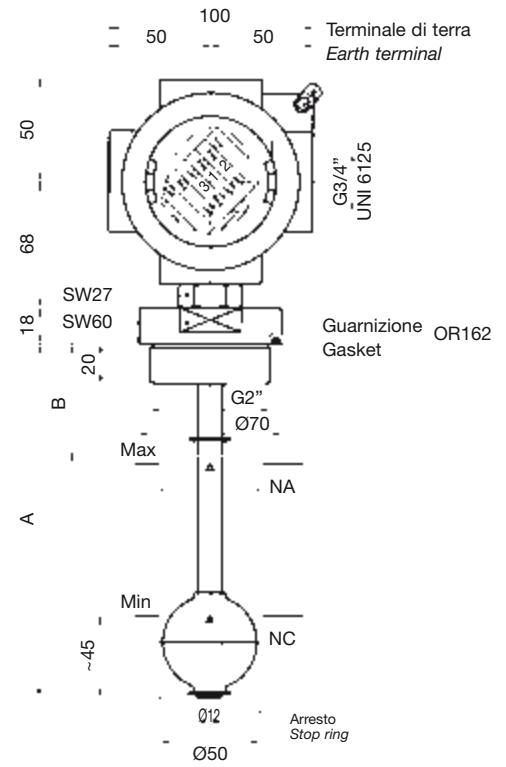

MATERIALI: flangia filettata, tubo, anelli di arresto e galleggiante in acciaio inox, custodia in alluminio pressofuso verniciato.

N.B. - A richiesta, forniamo lunghezze superiori, oppure diverse da quelle standard.

IMPIEGO

Sono stati studiati per controllare il livello di un liquido in un serbatoio e inviare a distanza un segnale elettrico. Devono essere montati verticalmente sul coperchio del serbatoio in modo che il galleggiante disti almeno 50 mm. dalle pareti metalliche.

DATI TECNICI COMUNI

Lunghezza asta max	A = 2500 mm
Campo di temperatura	-20°...+60°C
Peso specifico liquido	≥ 0,7
Pressione massima	20 Bar
Viscosità del fluido	max 150 cSt

DATI TECNICI LM1 - LMM1

Potenza commutabile in CC/CA	60 W/VA
Intensità di corrente	0.8 A (resistivo)
Tensione di lavoro	220 V - 50 Hz
Tensione di breakdown	300 V
Capacità dei contatti aperti	0,6 pF
Resistenza d'isolamento	10 ¹⁰ Ohm
Contatto a riposo (senza fluido)	
Livello min. (LM1-LMM1)	NC (NA su richiesta)
Livello max (LMM1)	NA (NC su richiesta)

DATI TECNICI LM2

Potenza commutabile in CC/CA	30 W/VA
Intensità di corrente	0.5 A (resistivo)
Tensione di lavoro	220 V - 50 Hz
Tensione di breakdown	300 V
Capacità dei contatti aperti	2 pF
Resistenza d'isolamento	10 ⁹ Ohm
Contatto a riposo	SPDT

MATERIAL: threaded flange, stem, stop rings and float in stainless steel, varnished die-cast aluminium housing.

N.B. - Customized executions can be supplied on request.

USE

This series of electromagnetic level switches has been designed to check a fluid level in a tank and send an electric signal to a remote board. They must be set vertically on the cover of the tank, with the float at least 50 mm far from metal walls.

COMMON SPECIFICATIONS

Stem max length	A = 2500 mm
Temperature range	-20...+60°C
Fluid specific gravity	≥ 0,7
Maximum pressure	20 Bar
Fluid viscosity	max 150 cSt

LM1-LMM1 SPECIFICATIONS

Switching capacity in DC/AC	60 W/VA
Current	0.8 A (resistive)
Voltage	220 V - 50 Hz
Breakdown voltage	300 V
Capacitance	0,6 pF
Insulation resistance	10 ¹⁰ Ohm
Contact (dry condition)	
Min level (LM1-LMM1)	NC (NO on request)
Max level (LMM1)	NO (NC on request)

LM2 SPECIFICATIONS

Switching capacity in DC/AC	30 W/VA
Current	0.5 A (resistive)
Voltage	220 V - 50 Hz
Breakdown voltage	300 V
Capacitance	2 pF
Insulation resistance	10 ⁹ Ohm
Contact (dry condition)	SPDT

LIVELLOSTATI ELETTROMAGNETICI

Conformi alla Direttiva 94/9/CE - II 1/2 GD Ex d IIB T6 Ex tD A21 IP65 T60°C



Float level switches

In accordance with Directive 94/9/EC - II 1/2 GD Ex d IIB T6 Ex tD A21 IP65 T60°C

LM3 GTA... B... C... EP

LM4 GTA... B... C... D... EP

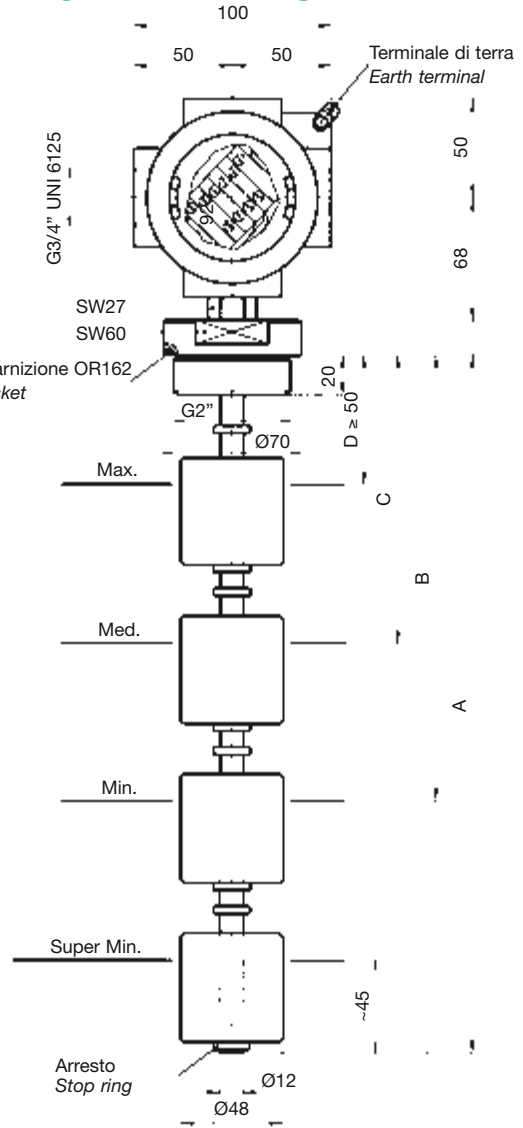
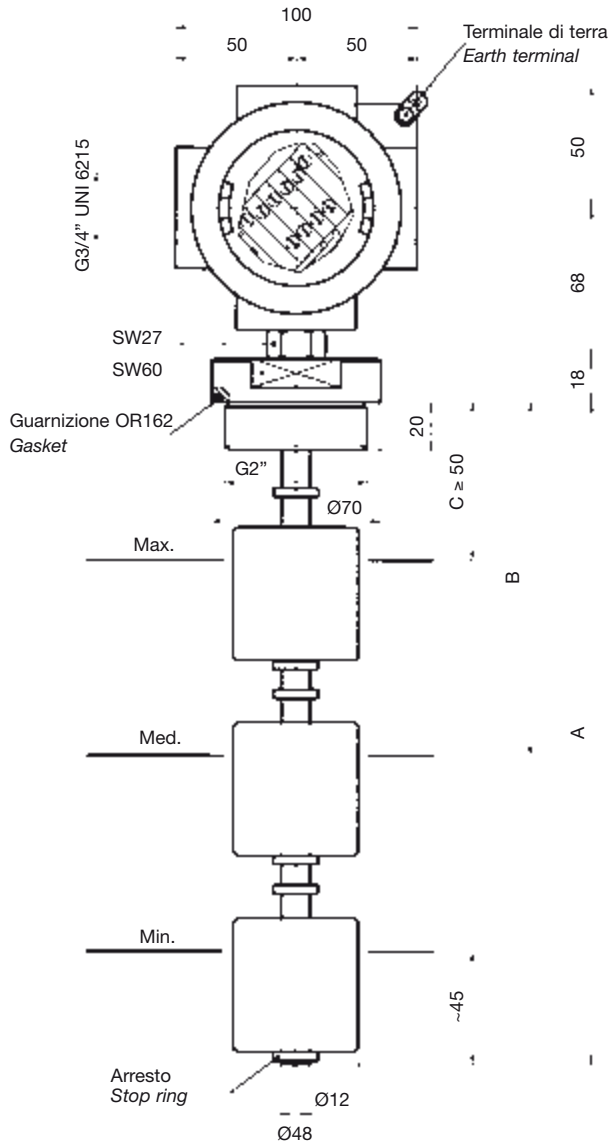

N.B. - Negli ordini, a seconda del modello, indicare le quote A - B - C - D. Min. distanza fra i contatti B - C - D = 90 mm.

Esempio di ordinazione: LM3GTA1200B500C100EP

MATERIALI: flangia filettata in ottone, tubo in ottone, anelli di arresto in ottone, galleggianti in resina espansa NBR, custodia in alluminio pressofuso verniciato.

IMPIEGO

Sono stati studiati per controllare il livello di un liquido in un serbatoio e inviare a distanza un segnale elettrico. Devono essere montati verticalmente sul coperchio del serbatoio in modo che il galleggiante disti almeno 50 mm. dalle pareti metalliche.

DATI TECNICI

Lunghezza asta max	A = 2500 mm
Potenza commutabile in CC	60 W
Potenza commutabile in CA	60 VA
Intensità di corrente	0.8 A (resistivi)
Tensione max. di lavoro	220 V - 50 Hz
Tensione di breakdown	300 V
Capacità dei contatti aperti	0,6 pF
Contatto a riposo (senza fluido)	NC (NA su richiesta)
Resistenza d'isolamento	10 ¹⁰ Ohm
Campo di temperatura	-20°...+60°C
Peso specifico liquido	≥ 0,7
Pressione massima	20 Bar
Viscosità del fluido	max 150 cSt

PER CARICHI INDUTTIVI IMPIEGARE CIRCUITO DI PROTEZIONE.

N.B. - When ordering, according to the model required, indicate A - B - C - D references.

Min. contact distance B - C - D = 90 mm.

Ordering example: LM4GTA1500B1200C200D50EP

MATERIAL: threaded flange in brass; brass stem; stop rings in brass; NBR float, varnished die-cast aluminium housing.

USE

This series of electromagnetic level switches has been designed to check a fluid level in a tank and send an electric signal to a remote board. They must be set vertically on the cover of the tank, with the float at least 50 mm far from metal walls.

SPECIFICATIONS

Stem max length	A = 2500 mm
Switching capacity in DC	60 W
Switching capacity in AC	60 VA
Current	0.8 A (resistive)
Voltage	220 V - 50 Hz
Breakdown voltage	300 V
Capacitance	0,6 pF
Contact (dry condition)	NC (NO on request)
Insulation resistance	10 ¹⁰ Ohm
Temperature range	-20°...+60°C
Fluid specific gravity	≥ 0,7
Maximum pressure	20 Bar
Fluid viscosity	max 150 cSt

WITH INDUCTIVE LOADS A PROTECTION CIRCUIT IS TO BE USED.

LIVELLOSTATI ELETTROMAGNETICI - INOX

Conformi alla Direttiva 94/9/CE - II 1/2 GD Ex d IIC T6 Ex tD A21 IP65 T60°C



Float level switches - Stainless steel

In accordance with Directive 94/9/EC - II 1/2 GD Ex d IIC T6 Ex tD A21 IP65 T60°C

LM3 GTIA... B... C... EP

LM4 GTIA... B... C... D... EP

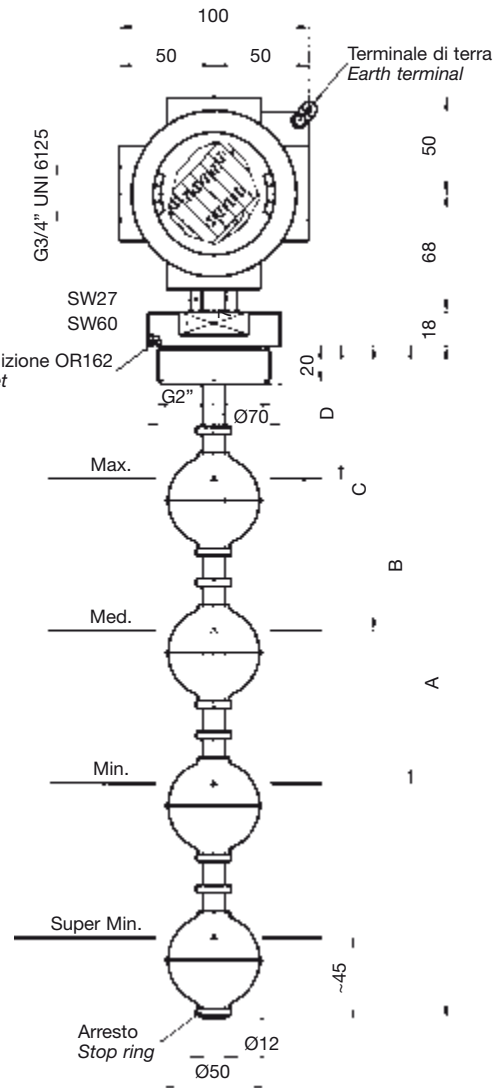
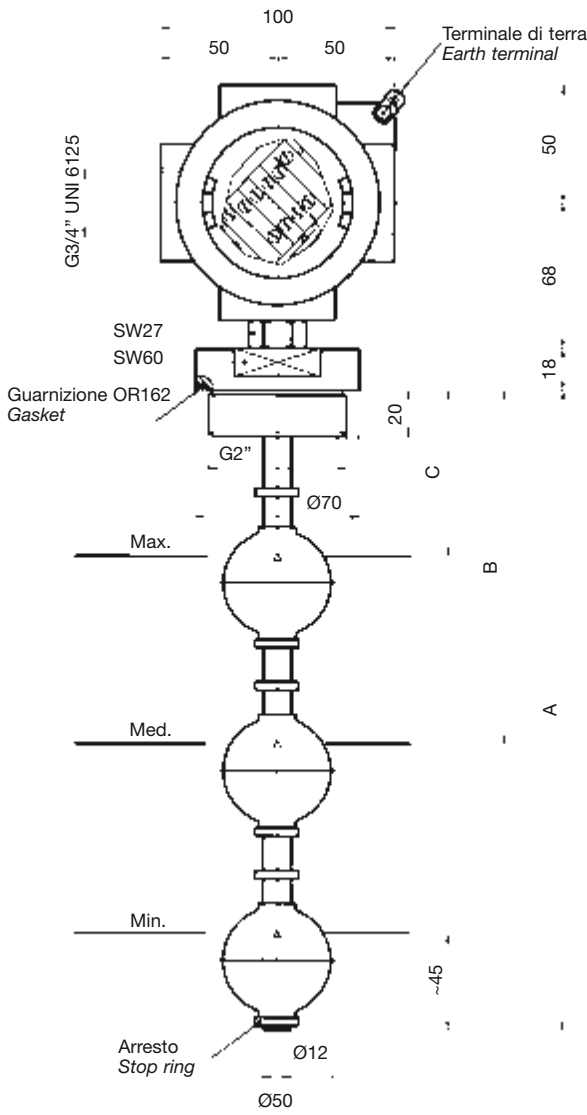

N.B. - Negli ordini, a seconda del modello, indicare le quote A - B - C - D. Min. distanza fra i contatti B - C - D = 90 mm.

Esempio di ordinazione: LM3GTIA1000B500C200EP

MATERIALI: flangia filettata, tubo, anelli di arresto e galleggiante in acciaio inox, custodia in alluminio pressofuso verniciato.

IMPIEGO

Sono stati studiati per controllare il livello di un liquido in un serbatoio e inviare a distanza un segnale elettrico. Devono essere montati verticalmente sul coperchio del serbatoio in modo che il galleggiante disti almeno 50 mm. dalle pareti metalliche.

DATI TECNICI

Lunghezza asta max	A = 2500 mm
Potenza commutabile in CC	60 W
Potenza commutabile in CA	60 VA
Intensità di corrente	0.8 A (resistivo)
Tensione max. di lavoro	220 V - 50 Hz
Tensione di breakdown	300 V
Capacità dei contatti aperti	0,6 pF
Contatto a riposo (senza fluido)	NC (NA su richiesta)
Resistenza d'isolamento	10 ¹⁰ Ohm
Campo di temperatura	-20°...+60°C
Peso specifico liquido	≥ 0,7
Pressione massima	20 Bar
Viscosità del fluido	max 150 cSt

PER CARICHI INDUTTIVI IMPIEGARE CIRCUITO DI PROTEZIONE.

N.B. - When ordering, according to the model required, indicate A - B - C - D references.

Min. contact distance B - C - D = 90 mm.

Ordering example: LM4GTIA1500B1200C200D50EP

MATERIAL: threaded flange, stem, stop rings and float in stainless steel, varnished die-cast aluminium housing.

USE

This series of electromagnetic level switches has been designed to check a fluid level in a tank and send an electric signal to a remote board. They must be set vertically on the cover of the tank, with the float at least 50 mm far from metal walls.

SPECIFICATIONS

Stem max length	A = 2500 mm
Switching capacity in DC	60 W
Switching capacity in AC	60 VA
Current	0.8 A (resistive)
Voltage	220 V - 50 Hz
Breakdown voltage	300 V
Capacitance	0,6 pF
Contact (dry condition)	NC (NO on request)
Insulation resistance	10 ¹⁰ Ohm
Temperature range	-20°...+60°C
Fluid specific gravity	≥ 0,7
Maximum pressure	20 Bar
Fluid viscosity	max 150 cSt

WITH INDUCTIVE LOADS A PROTECTION CIRCUIT IS TO BE USED.

LIVELLOSTATI ELETTROMAGNETICI IN PVC

Float level switches - PVC

LM1GSPA... LM2GSPA...

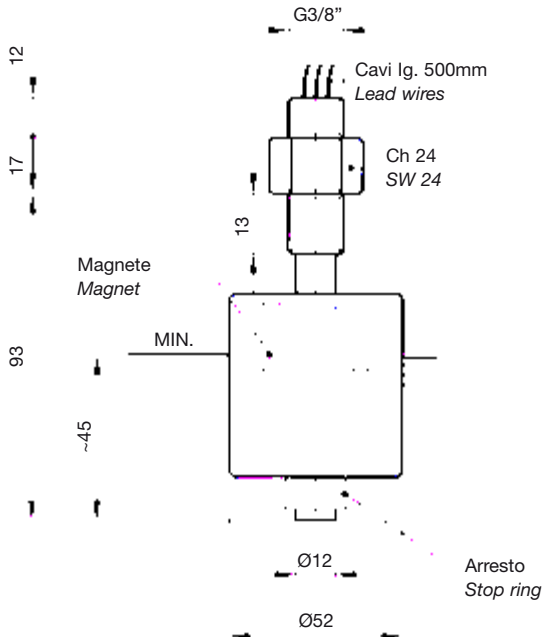

Schema di applicazione
Application chart

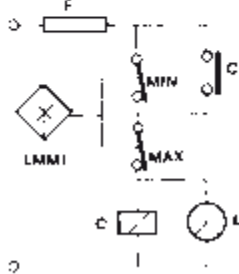
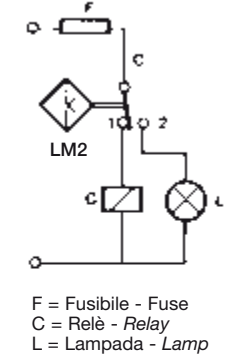

Riempimento automatico
Automatic filling

LMM1GSPA... B...

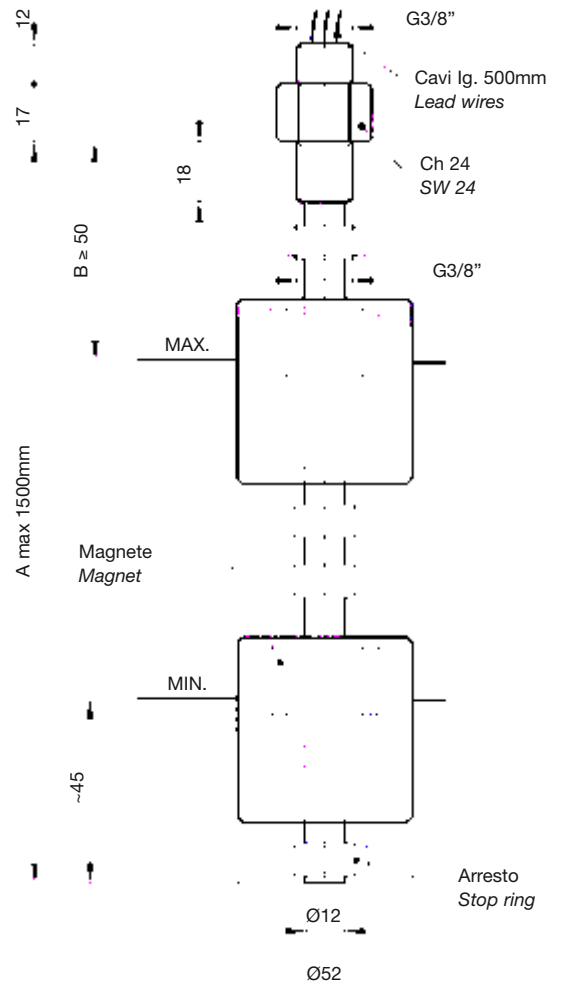

A max 1500mm

B ≈ 50

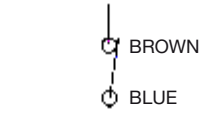

LM1GSPA
NC CONTACT

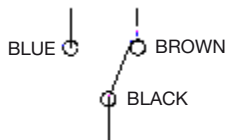

LM2GSPA
SPDT CONTACT

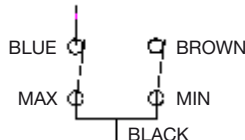

LMM1GSPA
MIN - MAX CONTACTS

N.B. - Negli ordini indicare le quote A e B.
N.B. - When ordering indicate A and B references.

IMPIEGO

Questi livellostati sono stati studiati per controllare il minimo o il massimo livello di un fluido contenuto in un serbatoio e per inviare un segnale elettrico di allarme a distanza. Devono essere montati verticalmente sul coperchio del serbatoio in modo che il galleggiante disti almeno 50 mm. dalle pareti metalliche ferrose.

DATI TECNICI COMUNI

Campo di temperatura	-5°...+50°C
Peso specifico liquido	≥ 0,85
Pressione massima	5 Bar
Viscosità del fluido	max 150 cSt
Materiale	esecuzione interamente in PVC

DATI TECNICI LM1 - LMM1

Potenza commutabile in CC/CA	60 W/VA
Intensità di corrente	0,8 A (resistivi)
Tensione di lavoro	220 V - 50 Hz
Tensione di breakdown	300 V
Capacità dei contatti aperti	0,6 pF
Resistenza d'isolamento	10 ⁹ Ohm
Contatto a riposo (senza fluido)	
Livello min. (LM1-LMM1)	NC (NA su richiesta)
Livello max (LMM1)	NC (NA su richiesta)

DATI TECNICI LM2

Potenza commutabile in CC/CA	30 W/VA
Intensità di corrente	0,5 A (resistivi)
Tensione di lavoro	220 V - 50 Hz
Tensione di breakdown	300 V
Capacità dei contatti aperti	2 pF
Resistenza d'isolamento	10 ⁹ Ohm
Contatto a riposo	SPDT

USE

This series of electromagnetic level switches has been designed to check the minimum or maximum level of a fluid in a tank and send an electric signal to a remote board in case the fluid goes over or under the set levels. They should be fixed vertically on the cover of the tank, with the float at least 50 mm far from metal walls.

COMMON SPECIFICATIONS

Temperature range	-5°...+50°C
Fluid specific gravity	≥ 0,85
Maximum pressure	5 Bar
Fluid viscosity	max 150 cSt
Material	all PVC execution

LM1-LMM1 SPECIFICATIONS

Switching capacity in DC/AC	60 W/VA
Current	0,8 A (resistive)
Voltage	220 V - 50 Hz
Breakdown voltage	300 V
Capacitance	0,6 pF
Insulation resistance	10 ⁹ Ohm
Contact (dry condition)	
Min level (LM1-LMM1)	NC (NO on request)
Max level (LMM1)	NC (NO on request)

LM2 SPECIFICATIONS

Switching capacity in DC/AC	30 W/VA
Current	0,5 A (resistive)
Voltage	220 V - 50 Hz
Breakdown voltage	300 V
Capacitance	2 pF
Insulation resistance	10 ⁹ Ohm
Contact (dry condition)	SPDT

LIVELLOSTATI ELETTROMAGNETICI IN PVC

Float level switches - PVC

LM3 GSPA... B... C...

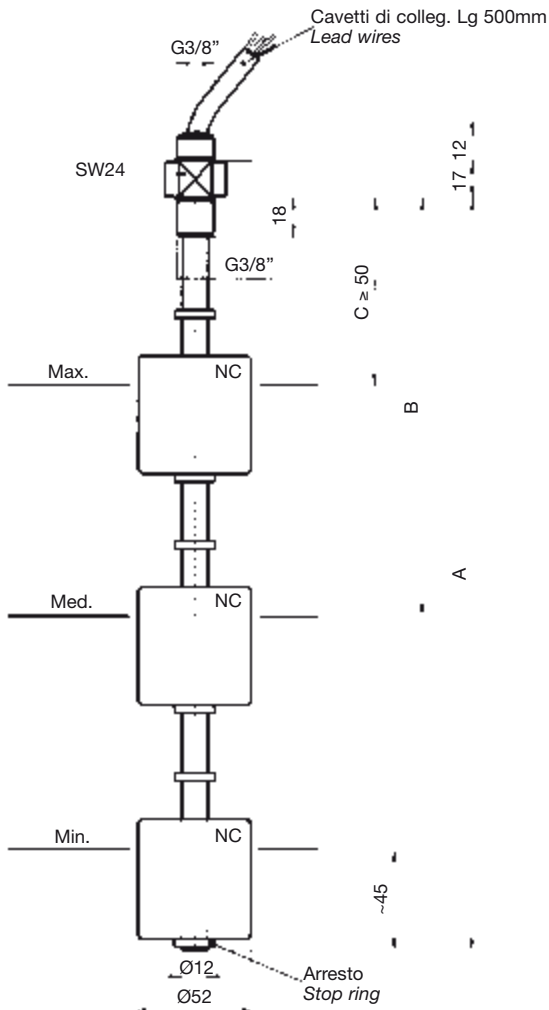

LM4 GSPA... B... C... D...

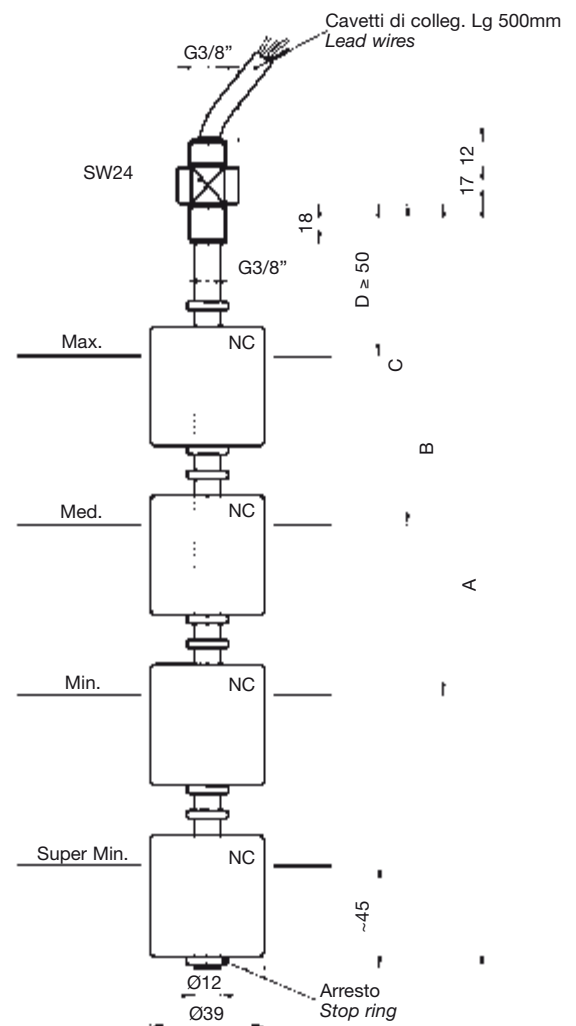

N.B. - Nelle ordini, a seconda del modello, indicare le quote A - B - C - D.
Min. distanza fra i contatti B - C - D = 90 mm.

Esempio di ordinazione: LM3GSPA1000B800C50

IMPIEGO

Sono stati studiati per controllare il minimo o il massimo livello di olio, acqua, solventi, in un serbatoio e per inviare a distanza un segnale elettrico. Devono essere montati verticalmente sul coperchio del serbatoio in modo che il galleggiante disti almeno 50 mm. dalle pareti metalliche ferrose.

DATI TECNICI

Lunghezza asta max	A = 2500 mm
Potenza commutabile in CC	60 W
Potenza commutabile in CA	60 VA
Intensità di corrente	0.8 A (resistivi)
Tensione max. di lavoro	~220 V - 50 Hz
Tensione di breakdown	300 V
Capacità dei contatti aperti	0,6 pF
Contatto a riposo (senza fluido)	NC (NA su richiesta)
Resistenza d'isolamento	10 ¹⁰ Ohm
Campo di temperatura	-5°...+50°C
Peso specifico liquido	≥ 0,85
Pressione massima	5 Bar
Viscosità del fluido	150 cSt
Materiale	esecuzione interamente in PVC

PER CARICHI INDUTTIVI IMPIEGARE CIRCUITO DI PROTEZIONE.

N.B. - When ordering, according to the model required, indicate A - B - C - D references.

Min. contact distance B - C - D = 90 mm.

Ordering example: LM4GSPA100B800C150D50

USE

This series of electromagnetic level switches has been designed to check the minimum or maximum level of a fluid in a tank and send an electric signal to a remote board in case the fluid goes over or under the set levels. They should be fixed vertically on the cover of the tank, with the float at least 50 mm far from metal walls.

SPECIFICATIONS

Stem max length	A = 2500 mm
Switching capacity in DC	60 W
Switching capacity in AC	60 VA
Current	0.8 A (resistive)
Voltage	~220 V - 50 Hz
Breakdown voltage	300 V
Capacitance	0,6 pF
Contact (dry condition)	NC (NO on request)
Insulation resistance	10 ¹⁰ Ohm
Temperature range	-5°...+50°C
Fluid specific gravity	≥ 0.85
Maximum pressure	5 Bar
Fluid viscosity	max 150 cSt
Material	all PVC execution

WITH INDUCTIVE LOADS A PROTECTION CIRCUIT IS TO BE USED.

LIVELLOSTATI ELETTROMAGNETICI IN PVC

Float level switches - PVC

LM1GPA... LM2GPA...

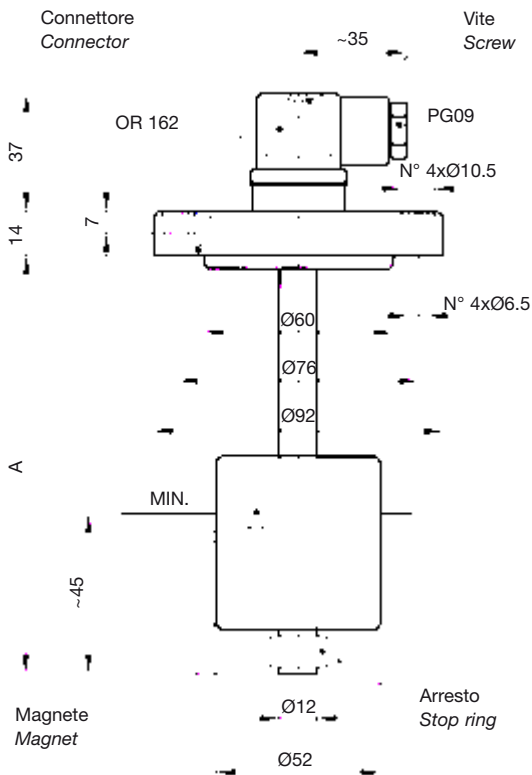

Collegamenti elettrici standard
Standard electrical connection

LM1GPA

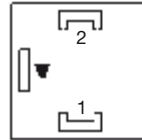

LM2GPA

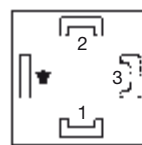

LMM1GPA

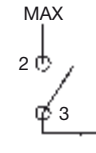
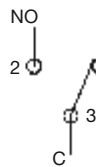
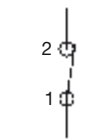
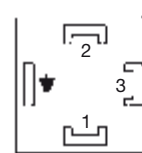

LMM1GPA... B...

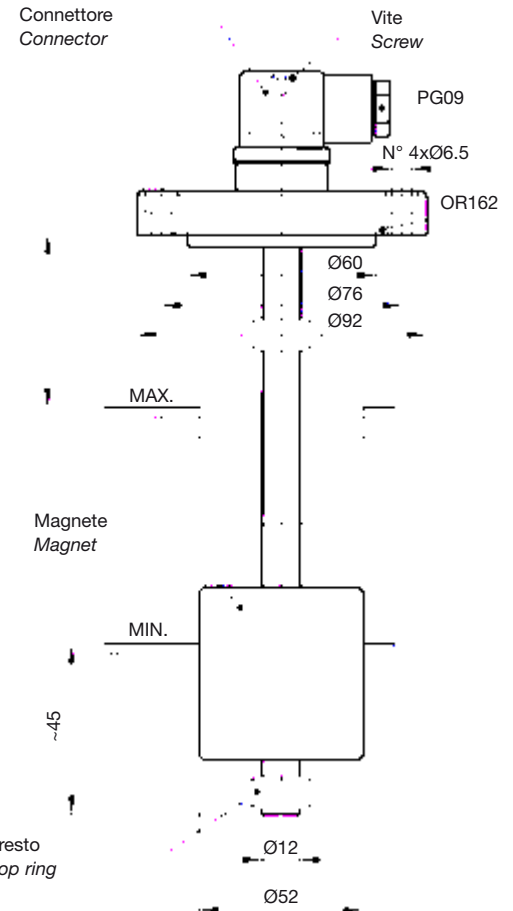

MATERIALE: flangia, tubo, anelli d'arresto e galleggiante in PVC.

N.B. - A richiesta, forniamo lunghezze superiori oppure diverse da quelle standard.

IMPIEGO

Sono stati studiati per controllare il livello di olio, acqua, solventi, in un serbatoio e per inviare a distanza un segnale elettrico. Devono essere montati verticalmente sul coperchio del serbatoio in modo che il galleggiante disti almeno 50 mm. dalle pareti metalliche.

DATI TECNICI COMUNI

Lunghezza asta max	A = 2500 mm
Campo di temperatura	-5°...+50°C
Peso specifico liquido	≥ 0,85
Pressione massima	5 Bar
Viscosità del fluido	max 150 cSt

DATI TECNICI LM1 - LMM1

Potenza commutabile in CC/CA	60 W/VA
Intensità di corrente	0.8 A (resistivi)
Tensione di lavoro	220 V - 50 Hz
Tensione di breakdown	300 V
Capacità dei contatti aperti	0,6 pF
Resistenza d'isolamento	10 ¹⁰ Ohm
Contatto a riposo (senza fluido)	NC (NA su richiesta)
Livello min. (LM1-LMM1)	NC (NA su richiesta)
Livello max (LMM1)	NA (NC su richiesta)

DATI TECNICI LM2

Potenza commutabile in CC/CA	30 W/VA
Intensità di corrente	0.5 A (resistivi)
Tensione di lavoro	220 V - 50 Hz
Tensione di breakdown	300 V
Capacità dei contatti aperti	2 pF
Resistenza d'isolamento	10 ⁹ Ohm
Contatto a riposo	SPDT

MATERIAL: flange, stem, stop rings and float in PVC.

N.B. - Customized executions can be supplied on request.

USE

This series of electromagnetic level switches has been designed to check the minimum or maximum level of a fluid in a tank and send an electric signal to a remote board in case the fluid goes over or under the set levels. They should be fixed vertically on the cover of the tank, with the float at least 50 mm far from metal walls.

COMMON SPECIFICATIONS

Stem max length	A = 2500 mm
Temperature range	-5°...+50°C
Fluid specific gravity	≥ 0,85
Maximum pressure	5 Bar
Fluid viscosity	max 150 cSt

LM1-LMM1 SPECIFICATIONS

Switching capacity in DC/AC	60 W/VA
Current	0.8 A (resistive)
Voltage	220 V - 50 Hz
Breakdown voltage	300 V
Capacitance	0,6 pF
Insulation resistance	10 ¹⁰ Ohm
Contact (dry condition)	NC (NO on request)
Min level (LM1-LMM1)	NC (NO on request)
Max level (LMM1)	NO (NC on request)

LM2 SPECIFICATIONS

Switching capacity in DC/AC	30 W/VA
Current	0.5 A (resistive)
Voltage	220 V - 50 Hz
Breakdown voltage	300 V
Capacitance	2 pF
Insulation resistance	10 ⁹ Ohm
Contact (dry condition)	SPDT

LIVELLOSTATI ELETTROMAGNETICI IN PVC

Float level switches - PVC

LM1GTPA... LM2GTPA...

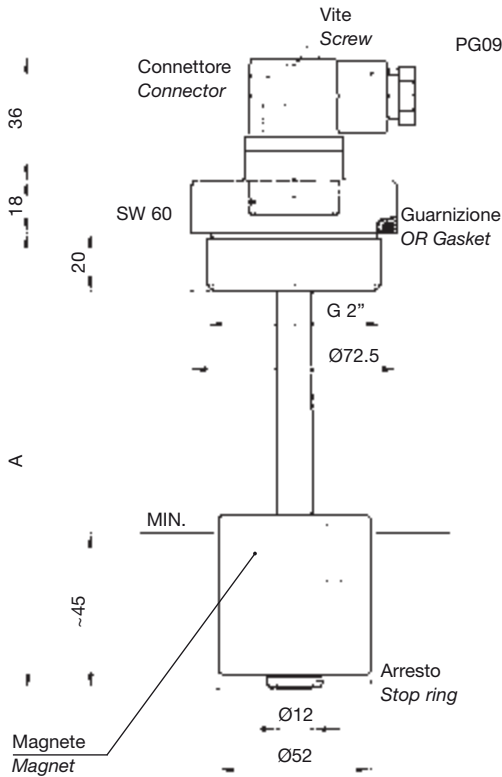

Collegamenti elettrici standard
Standard electrical connection

LM1GTPA

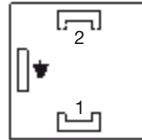

LM2GTPA

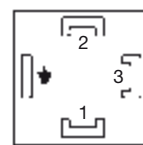

LMM1GTPA

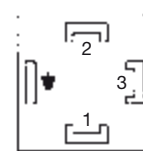

LMM1GTPA... B...

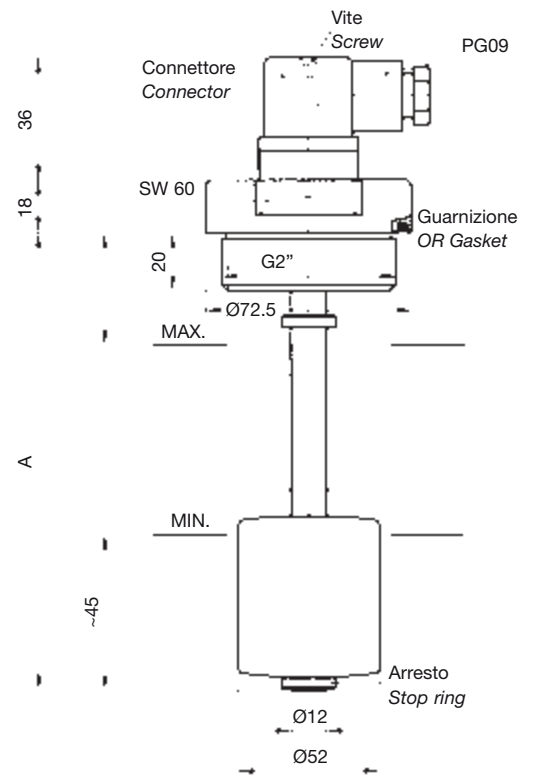

MATERIALE: flangia filettata, tubo, anelli d'arresto e galleggiante in PVC.

N.B. - A richiesta, forniamo lunghezze superiori oppure diverse da quelle standard.

IMPIEGO

Sono stati studiati per controllare il livello di olio, acqua, solventi, in un serbatoio e per inviare a distanza un segnale elettrico. Devono essere montati verticalmente sul coperchio del serbatoio in modo che il galleggiante disti almeno 50 mm. dalle pareti metalliche.

DATI TECNICI COMUNI

Lunghezza asta max	A = 2500 mm
Campo di temperatura	-5°...+50°C
Peso specifico liquido	≥ 0,85
Pressione massima	5 Bar
Viscosità del fluido	max 150 cSt

DATI TECNICI LM1 - LMM1

Potenza commutabile in CC/CA	60 W/VA
Intensità di corrente	0.8 A (resistivi)
Tensione di lavoro	220 V - 50 Hz
Tensione di breakdown	300 V
Capacità dei contatti aperti	0,6 pF
Resistenza d'isolamento	10 ¹⁰ Ohm
Contatto a riposo (senza fluido)	
Livello min. (LM1-LMM1)	NC (NA su richiesta)
Livello max (LMM1)	NA (NC su richiesta)

DATI TECNICI LM2

Potenza commutabile in CC/CA	30 W/VA
Intensità di corrente	0.5 A (resistivi)
Tensione di lavoro	220 V - 50 Hz
Tensione di breakdown	300 V
Capacità dei contatti aperti	2 pF
Resistenza d'isolamento	10 ⁹ Ohm
Contatto a riposo	SPDT

MATERIAL: threaded flange, stem, stop rings and float in PVC.

N.B. - Customized executions can be supplied on request.

USE

This series of electromagnetic level switches has been designed to check the minimum or maximum level of a fluid in a tank and send an electric signal to a remote board in case the fluid goes over or under the set levels. They should be fixed vertically on the cover of the tank, with the float at least 50 mm far from metal walls.

COMMON SPECIFICATIONS

Stem max length	A = 2500 mm
Temperature range	-5°...+50°C
Fluid specific gravity	≥ 0,85
Maximum pressure	5 Bar
Fluid viscosity	max 150 cSt

LM1-LMM1 SPECIFICATIONS

Switching capacity in DC/AC	60 W/VA
Current	0.8 A (resistive)
Voltage	220 V - 50 Hz
Breakdown voltage	300 V
Capacitance	0,6 pF
Insulation resistance	10 ¹⁰ Ohm
Contact (dry condition)	
Min level (LM1-LMM1)	NC (NO on request)
Max level (LMM1)	NO (NC on request)

LM2 SPECIFICATIONS

Switching capacity in DC/AC	30 W/VA
Current	0.5 A (resistive)
Voltage	220 V - 50 Hz
Breakdown voltage	300 V
Capacitance	2 pF
Insulation resistance	10 ⁹ Ohm
Contact (dry condition)	SPDT

LIVELLOSTATI ELETTROMAGNETICI IN PVC

Float level switches - PVC

LM4GPA... B... C... D...

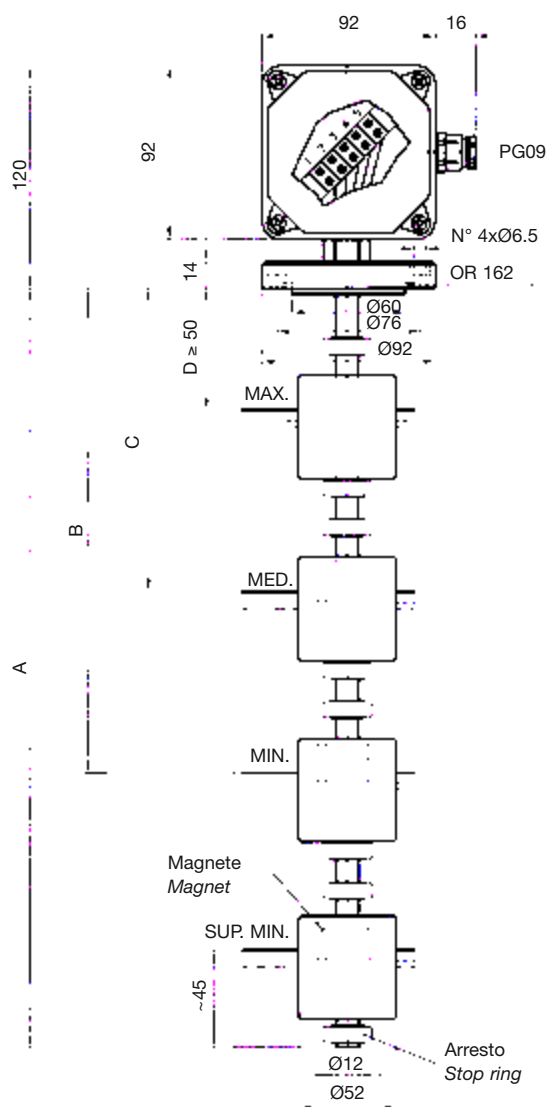

N.B. - Negli ordini, a seconda del modello, indicare le quote A - B - C - D.
Min. distanza fra i contatti B - C - D = 90 mm.

Esempio di ordinazione: LM4GPA1500B1200C200D50

IMPIEGO

Sono stati studiati per controllare livello di olio, acqua, solventi, in un serbatoio e inviare a distanza un segnale elettrico. Devono essere montati verticalmente sul coperchio del serbatoio in modo che il galleggiante disti almeno 50 mm. dalle pareti metalliche ferrose.

DATI TECNICI

Lunghezza asta max	A = 2500 mm
Potenza commutabile in CC	60 W
Potenza commutabile in CA	60 VA
Intensità di corrente	0.8 A (resistivi)
Tensione max. di lavoro	~220 V - 50 Hz
Tensione di breakdown	300 V
Capacità dei contatti aperti	0,6 pF
Contatto a riposo (senza fluido)	NC (NA su richiesta)
Resistenza d'isolamento	10 ¹⁰ Ohm
Campo di temperatura	-5°...+50°C
Peso specifico liquido	≥ 0,85
Pressione massima	5 Bar
Viscosità del fluido	150 cSt
Materiale	esecuzione in PVC

PER CARICHI INDUTTIVI IMPIEGARE CIRCUITO DI PROTEZIONE.

LM3GPA... B... C...

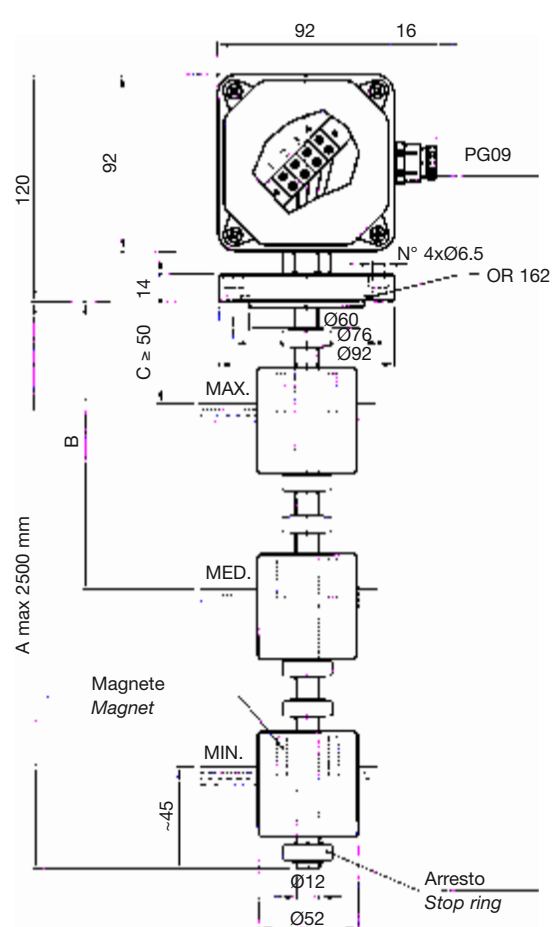

N.B. - When ordering, according to the model required, indicate A - B - C - D references.
Min. contact distance B - C - D = 90 mm.

Ordering example: LM3GPA1500B1250C50

USE

This series of electromagnetic level switches has been designed to check the level of a fluid in a tank and send an electric signal to a remote board in case the fluid goes over or under the set levels. They should be fixed vertically on the cover of the tank, with the float at least 50 mm far from metal walls.

SPECIFICATIONS

Stem max length	A = 2500 mm
Switching capacity in DC	60 W
Switching capacity in AC	60 VA
Current	0.8 A (resistive)
Voltage	~220 V - 50 Hz
Breakdown voltage	300 V
Capacitance	0,6 pF
Contact (dry condition)	NC (NO on request)
Insulation resistance	10 ¹⁰ Ohm
Temperature range	-5°...+50°C
Fluid specific gravity	≥ 0.85
Maximum pressure	5 Bar
Fluid viscosity	max 150 cSt
Material	all PVC execution

WITH INDUCTIVE LOADS A PROTECTION CIRCUIT IS TO BE USED.

LIVELLOSTATI ELETTROMAGNETICI IN PVC

Float level switches - PVC

LM4GTPA... B... C... D...

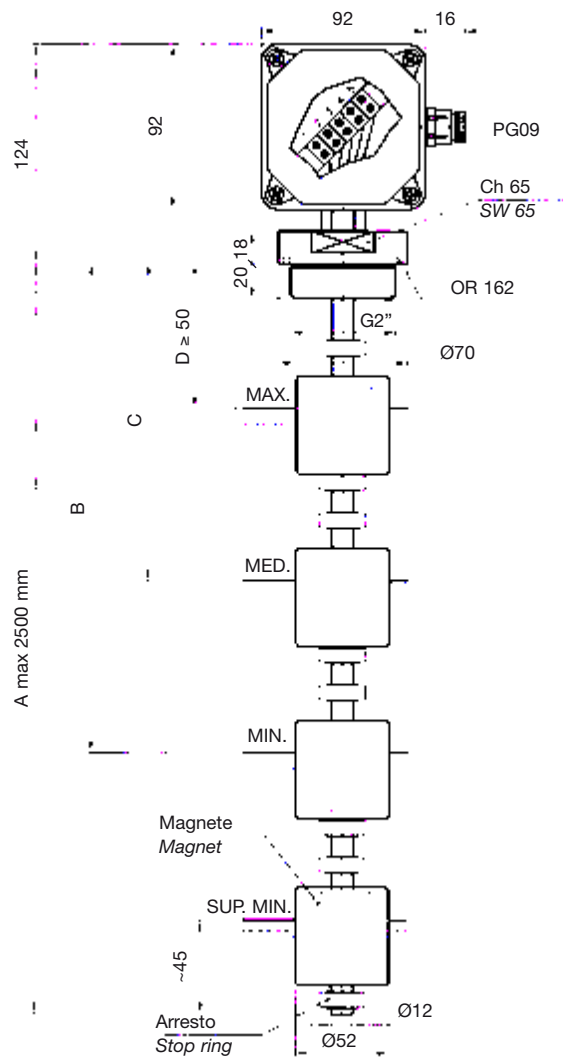

N.B. - Negli ordini, a seconda del modello, indicare le quote A - B - C - D.
Min. distanza fra i contatti B - C - D = 90 mm.

Esempio di ordinazione: LM4GTPA1500B1200C200D50

IMPIEGO

Sono stati studiati per controllare il livello di olio, acqua, solventi, in un serbatoio e inviare a distanza un segnale elettrico. Devono essere montati verticalmente sul coperchio del serbatoio in modo che il galleggiante disti almeno 50 mm. dalle pareti metalliche ferrose.

DATI TECNICI

Lunghezza asta max	A = 2500 mm
Potenza commutabile in CC	60 W
Potenza commutabile in CA	60 VA
Intensità di corrente	0.8 A (resistivi)
Tensione max. di lavoro	~220 V - 50 Hz
Tensione di breakdown	300 V
Capacità dei contatti aperti	0,6 pF
Contatto a riposo (senza fluido)	NC (NA su richiesta)
Resistenza d'isolamento	10 ¹⁰ Ohm
Campo di temperatura	-5°...+50°C
Peso specifico liquido	≥ 0,85
Pressione massima	5 Bar
Viscosità del fluido	150 cSt
Materiale	esecuzione interamente in PVC

PER CARICHI INDUTTIVI IMPIEGARE CIRCUITO DI PROTEZIONE.

LM3GTPA... B... C...

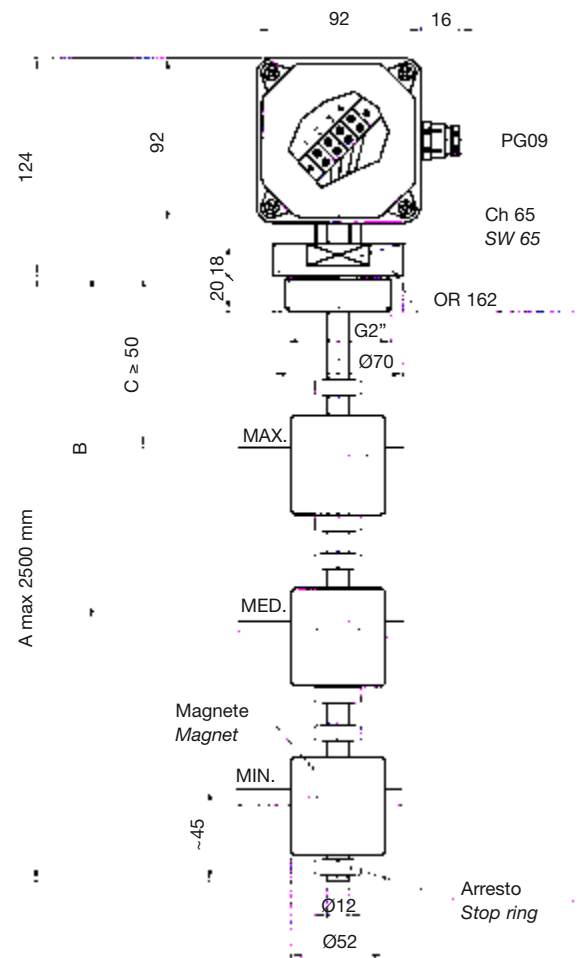

N.B. - When ordering, according to the model required, indicate A - B - C - D references.
Min. contact distance B - C - D = 90 mm.

Ordering example: LM3GTPA1000B800C50

USE

This series of electromagnetic level switches has been designed to check the level of a fluid in a tank and send an electric signal to a remote board in case the fluid goes over or under the set levels. They should be fixed vertically on the cover of the tank, with the float at least 50 mm far from metal walls.

SPECIFICATIONS

Stem max length	A = 2500 mm
Switching capacity in DC	60 W
Switching capacity in AC	60 VA
Current	0.8 A (resistive)
Voltage	~220 V - 50 Hz
Breakdown voltage	300 V
Capacitance	0,6 pF
Contact (dry condition)	NC (NO on request)
Insulation resistance	10 ¹⁰ Ohm
Temperature range	-5°...+50°C
Fluid specific gravity	≥ 0.85
Maximum pressure	5 Bar
Fluid viscosity	max 150 cSt
Material	all PVC execution

WITH INDUCTIVE LOADS A PROTECTION CIRCUIT IS TO BE USED.

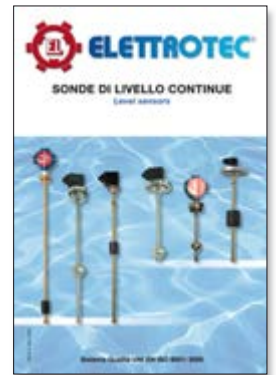
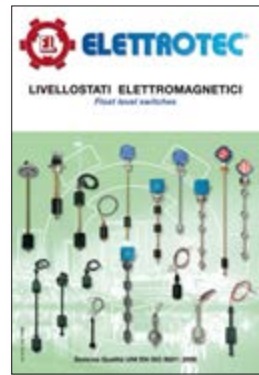
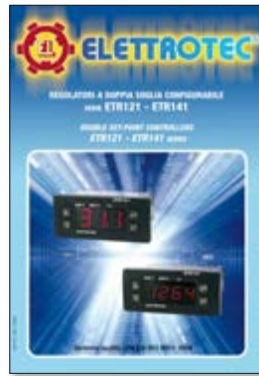
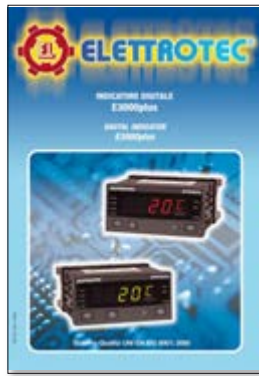
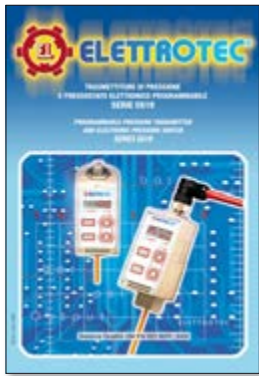

- Disponibile catalogo generale su CD-ROM
- CD-ROM master catalogue also available.

Azienda / Company _____

Via / Address _____ CAP / ZIP _____

Città / Town _____ Stato / Country _____

Tel. / Phone _____ Fax _____ Email _____

Settore / Company activity _____

Nome / Name _____ Cognome / Surname _____

Posizione / Title _____

Inviare a / Send to ELETTRROTEC S.r.l. - Via Jean Jaurés, 12 - 20125 Milano - Italy oppure al no. / or fax to: **+39 0228851854**

APPARECCHI DI CONTROLLO PER FLUIDI

Control Devices for Fluids

- Pressostati
- Vuotostati
- Termostati
- Flussimetri
- Flussostati
- Livellostati
- Sensori di livello
- Pressostati elettronici
- Trasmettitori di pressione
- Indicatori digitali
- Cappucci di protezione
- Connettori
- Esecuzioni speciali
- Pressure switches
- Vacuum switches
- Temperature switches
- Flow meters
- Flow switches
- Float level switches
- Level sensors
- Electronic pressure switches
- Pressure transmitters
- Digital indicators
- Protection caps
- Connectors
- Custom executions

I dati tecnici indicati nel presente catalogo sono l'esito delle prove effettuate al momento dell'uscita del prodotto. Sono oggetto di continui studi e, pertanto, sono suscettibili di modifiche senza preavviso alcuno.

ELETTROTEC srl si riserva la facoltà di apportare modifiche al presente catalogo in qualsiasi momento. È vietata la riproduzione anche parziale.

È esclusiva responsabilità dell'utilizzatore accertare l'idoneità dei prodotti, per ogni applicazione o uso specifico.

The technical data written in this catalogue are the result of tests made at the time of the release of the product. Being these data subjected to continuous tests, they can be modified at any time without previous notice.

Due to a policy of continuous development we reserve the right to amend specifications without prior notice. No part of this publication may be reproduced, stored in a retrieval system or transmitted in any form or by any means without prior permission of ELETTROTEC srl.

It is the sole responsibility of the user to determine the suitability of any product or information supplied by ELETTROTEC for any application or use by the user.

