

## BrikStar M BrikStar MD

Hydraulic briquetting machines  
for metal processing.



**HÖCKER®**  
**POLYTECHNIK**

*Always one idea ahead*



Volume reduction  
of up to 90%.

**BrikStar M**  
**BrikStar MD**

Hydraulic briquetting  
machines

## Use potentials effectively.

In metal processing large amounts of waste products such as grinding sludge and metal swarf or shavings occur. Their value is not recognized or remains unused. Usually due to the high content of cooling lubricants they have to be disposed of at very high cost or achieve only low scrap revenue. However these wastes could be optimized by using a high performance briquetting machine from HÖCKER POLYTECHNIK. Whether it concerns the processing of short, loose metal swarf from mechanical machining of non-ferrous metal, steel or cast iron parts or others as for example aluminium or magnesium, the briquetting machine series M and MD are optimally suitable.

### How it works

Both series compact the material with two compacting cylinders. Two horizontal main press cylinders compact the material simultaneously from both ends to form briquettes. This intelligent technique makes sure that the compaction is much higher and the briquettes contain less residual coolant and have a higher density. The expressed cooling lubricants can be recycled.

Both types are optimal for the high-quality briquette production in metal processing. Wear is quite low as the counter-pressure is created by the second main cylinder and not by friction. The pressing cylinder exerts a pressure on the material of up to 400 MPa. The standard PLC-control offers the possibility to variably adjust the pressure to gain the required density of the briquettes without problems.

Standard oil-cooling





**All advantages of BrikStar M and BrikStar MD:**

- Compact and space-saving construction
- Variable adjustable pressure
- Easy adjustable briquette density
- Low wear because of two main compacting cylinders
- Easy assembly
- Savings of up to 95 % of new oil or coolant quantities
- Low storing, transport and discharge resources
- Very resistant to corrosion
- Quick return on investment from sale of briquettes
- Sustainable and environmentally friendly operation
- Briquettes with low residual moisture for optimal melting

**HÖCKER®  
POLYTECHNIK**



## Something for every application.

To meet every demand both types are available with different throughputs, briquette diameters and hydraulic performances. While the BrikStar M has a throughput of 200 up to 1000 kg/h, the BrikStar MD is able to process about 1200 kg/h maximum due to the standard construction with double speed hydraulic cylinders. By the use of this special hydraulics the BrikStar MD is extremely efficient.

Both series show off even in the smallest space. Especially the BrikStar MD has a very compact construction. The briquetting machines are delivered ready to plug-in thus keep the cost of assembly low. Only a selection of the right hopper has to be made. Therefore HÖCKER POLYTECHNIK provides heavy-duty hoppers that can be adopted and modified for every application.

### Technical Data

	Unit	BrikStar MD 15/55	BrikStar MD 15/60	BrikStar MD 22/70	BrikStar MD 30/80	BrikStar MD 45/85	BrikStar MD 45/90
Throughput	kg/h	400	470	650	850	1000	1200
Briquette diameter	mm	55	60	70	80	85	90
Power consumption	kW	15	15	22	30	45	45

	Unit	BrikStar M 15/60	BrikStar M 22/70	BrikStar M 30/80	BrikStar M 40/85	BrikStar M 50/90
Throughput	kg/h	200	350	500	800	1000
Briquette diameter	mm	60	70	80	85	90
Power consumption	kW	15	22	30	37,5	47,5

\* The throughput of a briquetting machine depends very much on the kind of material and the apparent density. The specified values are averages for free-flowing cast iron swarf.



« integrated  
pump for cooling lubricants

pressing out »  
and recycling of  
cooling lubricants



BrikStar MD 15/55  
with feeding chute

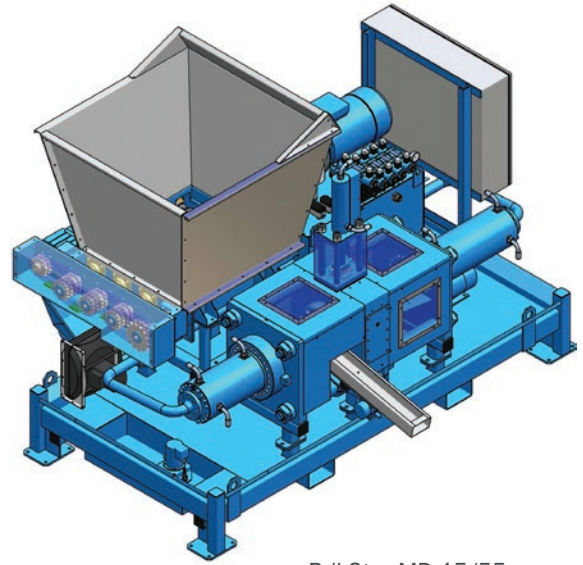
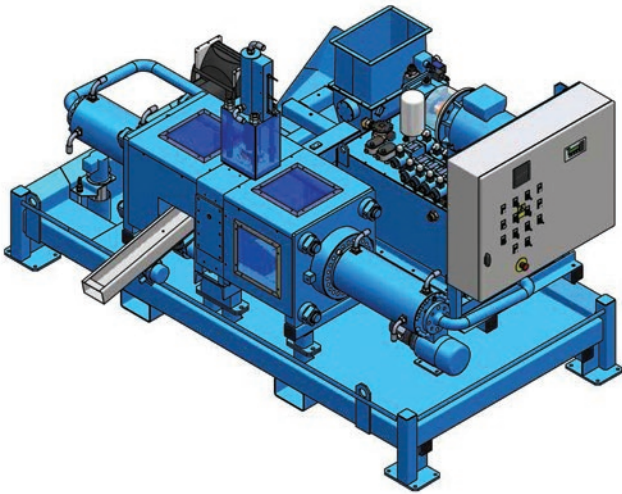

BrikStar MD 15/55  
Feed hopper with  
4-fold screw bed

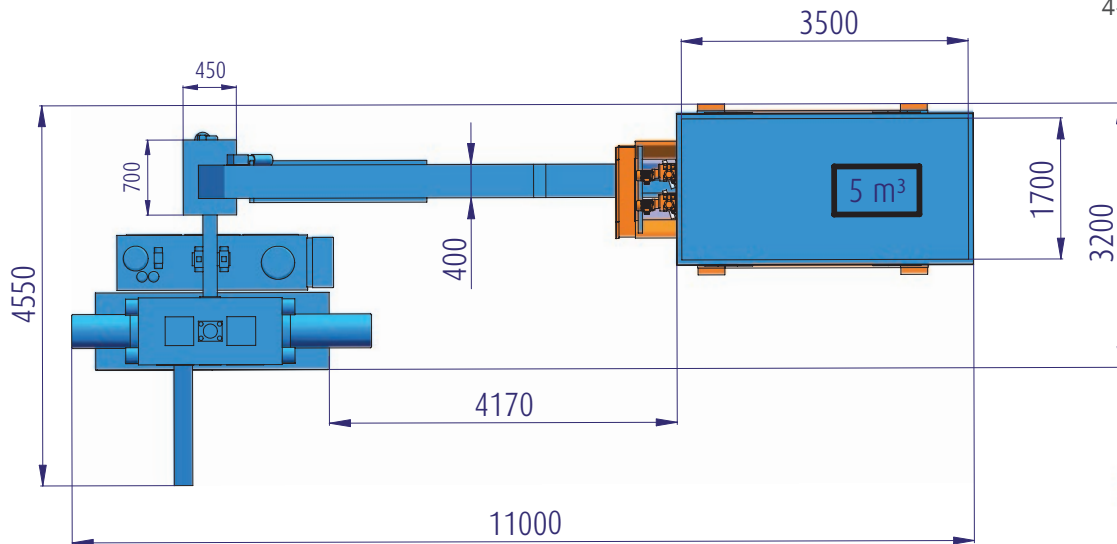

Example of installation of a BrikStar M 30/80  
with vibration screening and feeding system

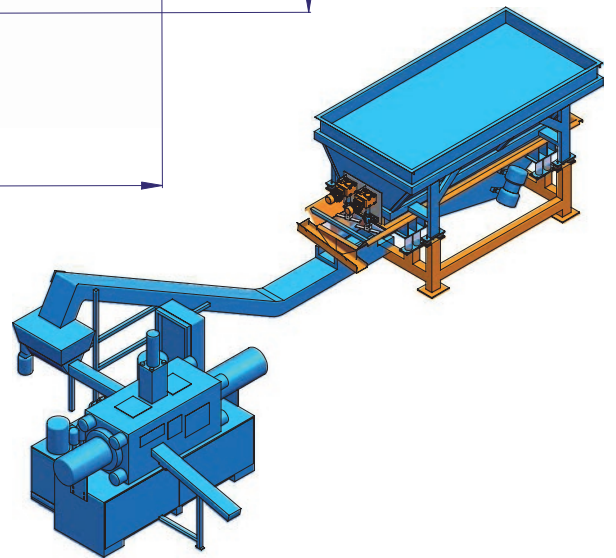

Hydraulic feeding cylinder

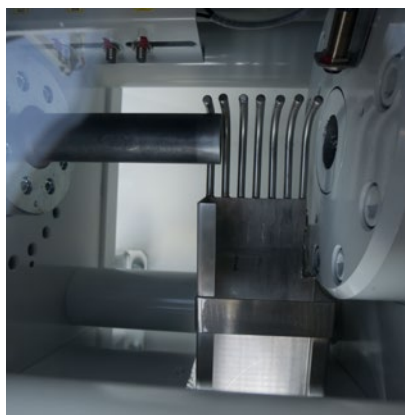

HÖCKER®  
POLYTECHNIK



## An investment, that pays off.

With the use of a BrikStar M or MD from HÖCKER POLYTECHNIK in your production process high efficient solutions can be achieved by changing valuable production waste and recyclable materials. Whether recycling, recovery of valuable material, draining, de-oiling etc., the range of applications are versatile:

- By briquetting cooling lubricants or cutting oils are separated from the swarf. These oils can immediately be recycled. Considerable costs can be saved as up to 95% of the cooling lubricants or cutting oils can be saved.
- The waste occurred in production processes can be pressed into compact and handy briquettes. Considerable revenues can be achieved by the sale of briquettes.
- Further savings are achieved in the area of company internal logistics, cost-savings of transport costs, higher container loads, no more storage containers.

Due to their compact and plug-n-play construction all HÖCKER POLYTECHNIK briquetting machines can be easily integrated in existing production processes. The hydraulic briquetting machines M and MD can be optimally combined with HÖCKER POLYTECHNIK filter systems for the separating of dry metal swarf and dust. For the processing of the pressed out cooling lubricants we gladly recommend capable suppliers.



**HÖCKER®**  
**POLYTECHNIK**

## Profitability of a hydraulic briquetting press for metal processing:

### Sample calculation for total saving of oily grinding sludge

		without briquetting	with briquetting
<b>Disposal volume</b> (in metric t/p.a.)	solids	200 metric t	200 metric t
	cutting oil	200 metric t	18 metric t
	total volume of disposal	400 metric t	218 metric t
	<b>oil saving</b>	-	<b>182 metric t</b>
<b>Need of fresh oil</b> (in €/p.a., 1 metric t = 1400 €)	need of fresh oil	200 metric t	18 metric t
	need of fresh oil	280.000 €	25.200 €
	<b>fresh oil saving</b>	-	<b>254.800 €</b>
<b>Disposal costs</b> (in €/p.a., 1 metric t = 100 €)	disposal volume	400 metric t	-
	disposal costs	40.000 €	-
	<b>disposal saving</b>	-	<b>40.000 €</b>
<b>Sale revenue</b> (in €/p.a.)	sales volume	-	218 metric t
	sales price	-	50 €/metric t
	sales revenue	-	10.900 €
	<b>sales revenue</b>	-	<b>10.900 € €</b>
<b>Total cost report</b>	disposal costs	40.000 €	-
	sales revenue	-	10.900 €
	need of fresh oil	280.000 €	25.200 €
	total costs	320.000 €	14.300 € □
	<b>total saving</b>	-	<b>305.700 € €</b>

### Sample calculation for total saving of oily aluminium swarf

		without briquetting	with briquetting
<b>Disposal volume</b> (in metric t/p.a.)	solids	500 metric t	500 metric t
	cutting oil	125 metric t	25 metric t
	total volume of disposal	625 metric t	525 metric t
	<b>oil saving</b>	-	<b>100 metric t</b>
<b>Need of fresh oil</b> (in €/p.a., 1 metric t = 1400 €)	need of fresh oil	125 metric t	25 metric t
	need of fresh oil	175.000 €	35.000 €
	<b>fresh oil saving</b>	-	<b>140.000 €</b>
<b>Sale revenue</b> (in €/p.a.)	sales volume	625 metric t	525 metric t
	sales price	500 €/metric t	700 €/metric t
	sales revenue	312.500 €	367.000 €
	<b>sales revenue</b>	-	<b>55.000 €</b>
<b>Total income statement</b> (in €)	sales revenue	312.500 €	367.500 €
	need of fresh oil	175.000 €	- 35.000 €
	total	137.500 €	332.500 €
	<b>profit</b>	-	<b>195.000 €</b>

## Excerpt from our list of references

Al Reyami Office Dubai, UAE · Alcan Aviatube, FRA · Alcom, BEL · Almet AG, GER · Arabian Packaging Dubai, UAE · ASCO Industries, BEL · BHS Corrugated, GER · Bien Haus AG, GER · Bikar Metalle, GER · Bilfinger & Berger, GER · Blitz Print Kiev, UKR · BMW Group Munich, GER · Boehringer Ingelheim, GER · Bogfran Möbel, POL · Cleanaway, GER · Daimler Chrysler AG, GER · Data Industries, USA · Delta Usinages, FRA · Detech S.A., SUI · Deutsche Bahn AG, GER · Dekker Hout, NEL · Dobergo Büromöbel, GER · DEHA Holzindustrie, GER · Dublin Institute of Technology, IRE · Dula Werke, GER · Duropack AG, GER · Egger Elemente, GER · Elastoform Möbelfabrik, GER · Elastogran Kunststoffe, GER · Emirate Deers, UAE · Eurowell, GER · Fine Irish Pine, IRL · FMD Möbel GmbH, GER · Frank Druck, GER · Frisia Möbelteile, GER · Garant Türen und Zargen, GER · GKU Alcan, GER · Glenwood, IRL · Greenline, UAE · Gulf Timber Factory, UAE · Häcker Küchen, GER · Handwerkskammer Aachen, GER · Handwerkskammer Osnabrück, GER · Heckewerth Holzwerkstoffe, GER · Heitz Furniere, GER · Herlitz Berlin, GER · Hohenhausen Soltau, GER · Holz-BG Köln, GER · Holzfachschule Bad Wildungen, GER · Holzfachschule Melle, GER · Holzma Calw, GER · Homag AG Schopfloch, GER · Horvath, HUN · Hymer Caravan, GER · Jaquar Ltd., IND · JVA Aachen, GER · JVA Burg, GER · JVA Geldern, GER · JVA Herford, GER · Karibu Bremen, GER · Klemz Isolierstoffe, GER · KIMADO, JPN · Kosche Profilmantelungen, GER · Kurekss, LAT · Kusch & Co., GER · Latvia Finieris Group, LAT · Lefevre, BEL · Lerom, RUS · Ligne Roset, FRA · Lottner AG, SUI · Maghreb Emballage, ALG · Marquardt Küchen, GER · Neuform Türenwerk, GER · Nobilia Küchen, GER · Obeikan Group Riyad, KSA · Oberhessisches Holzwerk, GER · OBI Baumärkte, GER · Pelipal Quickset Möbel, GER · Peri Schalungsbau, GER · Plywood Factory Archangelsk, RUS · Poppensieker & Derix, GER · Potteau Labo, BEL · Rollwood Holztechnik, GER · Salzgitter Magnesium Technologie, GER · Schwörer Fertighäuser, GER · Seibel & Weyer, GER · Seitz Kunststoffe, GER · SIA Troja, LAT · Siemens AG, GER · Simona Kunststoffe AG, GER · Stelmet S.A., POL · Stihl, NEL · Svedex binnendeuren, NEL · Swedwood IKEA, GER · Stark Druck, GER · Storaenso, FIN · Storebest Ladenbau, GER · Stork Fokker, NEL · Swatch Group, SUI · Theuma Türen, BEL · Towa Industry, RP Verems SIA, LAT · Verisett AG, SUI · Viking Windows, EST · Visagino linija (SBA furniture), LTU · Visy Paper, USA · WDR Köln, GER · Weidmann Electrical Technology, SUI · Wella AG, GER · Zenker Haus, GER

## We have delivered globally more than 50,000 systems in just over 50 years.

■ Countries where HÖCKER POLYTECHNIK has reference customers

